

UNIwersytet im. Adama Mickiewicza w Poznaniu
Wydział Neofilologii
Katedra Skandynawistyki

Przemysław Czarnecki

The phonology of quantity in Icelandic and Norwegian

Praca doktorska napisana pod kierunkiem
prof. dr hab. Grzegorza Skommera

Poznań 2013

The most remarkable fact about phonological phenomena is that they exist at all

Jonathan Kaye (1989): *Phonology: a cognitive view*. Hillsdale: Erlbaum

Contents:

Introduction.....	5
Chapter 1. Sounds of Icelandic and Norwegian.....	9
1.1 Vowels.....	9
1.2. Consonants.....	12
1.3. A note on stress and its relation to vowel length.....	15
Chapter 2. The main assumptions of the theoretical framework.....	18
Chapter 3. Quantity in Icelandic and Norwegian – “open syllable lengthening”.....	25
Chapter 4. Branching onsets in Icelandic and Norwegian.....	30
4.1. Branching onsets in Norwegian.....	31
4.2. Branching onsets or a sequence of simplex onsets?.....	33
4.3. Word-initial consonant clusters.....	36
4.4. Possible and impossible branching onsets in Icelandic.....	38
4.5. Icelandic non-onsets.....	39
4.6. Branching onsets vs. preaspiration.....	42
4.7. Impossible onsets and stopness sharing.....	45
4.8. True branching onsets in Icelandic.....	47
4.9. A side-glance to Faroese.....	48
Chapter 5. Preaspiration in Icelandic – more about melody and syllabic structure.....	50
5.1. Melodic interpretation of preaspiration.....	53
5.2. Syllabic status of preaspiration.....	57
Chapter 6. Quantity and the Norwegian retroflex consonants.....	60
6.1. What is a retroflex?.....	60
6.2. The syllabic status of retroflex consonants with respect to vowel quantity.....	61
Chapter 7. Stressed vowels in closed syllables.....	72
7.1. Short vowel before geminated consonants.....	75
7.2. Reversible governing relations in Modern Icelandic.....	76
Chapter 8. On a double agent in Icelandic phonology- the story of [s].....	81
8.1. The genitival –s.....	83
8.2. Spirantisation of the plosives.....	85
Chapter 9. Phonology vs. morphology - vocalic quantity in Icelandic compounds and derived words.....	90
9.1. More about the double nature of /s/.....	93

Chapter 10. The phonology of past tense in Norwegian and Icelandic.....	97
10.1. Past tense in Norwegian – data and problems.....	97
10.1.1. Excursion – geminates and licensing abilities of empty nuclei.....	101
10.1.2. Turning back to the past.....	104
10.2. Past tense in Icelandic – similarities and differences.....	115
References.....	124
STRESZCZENIE.....	136

Introduction

The following dissertation aims to shed some light on a prominent prosodic feature in two closely related languages Icelandic and Norwegian, namely quantity.¹ The phonological status of vocalic quantity (especially in Icelandic) has attracted numerous studies before (see the reference list), many of which conflict drastically in the interpretation of the phenomenon. Questions that were raised concentrated among other things on whether length is contrastive or “underlying” or rather context-dependent. In recent literature rather the latter position is taken. In brief, it is assumed that vowels are long in stressed monosyllables and if followed by a single consonant, i.e. in an open syllable (see HÖSKULDUR THRÁINSSON 1994: 149). In consequence, a stressed vowel followed by a consonant cluster must be short (closed syllable). However, a closer look at the data shows that the situation is far from being as simple as presented above. Even the notion of the open syllable seems to be problematic. Traditionally, open syllables are syllables that terminate in a vowel. Every syllable with what has been called the coda has been treated as closed. This seems to have been the most widely accepted view on the syllabic structure (see e.g. FUDGE 1969, SELKIRK 1982, to mention just two of some classic works). It would mean that forms as Icelandic *sæl* [sai:l] (blessed, fem.) or Norwegian *tak* [tʰa:kʰ] (roof) should be regarded as irregular (long vowels in closed syllables). An arbitrary marker has been introduced to solve this problem, namely the so-called *extrasyllabicity*, with no explanatory power.

Even if one accepts the definition of HÖSKULDUR THRÁINSSON (1994), one faces another problem directly connected to the notion of the open syllable, namely word-internal and word-final consonant clusters that are preceded by a long vowel, something that hardly found any interest in the literature. In forms like Ic. *sötr* [sœtʰr] or Norw. *Afrika* [a:frikʰa] the stressed vowel is long, although a consonant cluster follows. No explanation for this particular phonological environment has ever been given in the literature so far.

As it seems, traditional accounts have not been able to explain some problems connected to the distribution of long and short vowels in Icelandic and Norwegian. Some intriguing and often crucial aspects of the phonology of quantity have been totally omitted, like e.g. length in compounds, length in the past tense and many others. The following

¹ To avoid terminological confusion, one important clarification is needed already at this point. In the following dissertation the terms “length” and “quantity” will be used as synonyms. However, in the literature one can find a distinction between “length”, i.e. the relative durational property of segments, and thus a purely phonetic feature, and “quantity”, which is understood as a structural property of the syllables (see e.g. LASS 1984: 254). Clearly, only the latter will be taken into consideration in this dissertation.

dissertation is an attempt to analyze the phonology of quantity on the basis of modern generative theoretical framework, namely Government Phonology. Some traditional analyses will be discussed and clarified from a new perspective, some new proposals will be made.

Chapter 1 briefly presents sound inventories of Icelandic and Norwegian. Although lists of sounds have little to say about the phonological system of any language, they can serve as a starting point for a phonological discussion. This chapter discusses also in few words the prosodic hierarchy of the Icelandic and Norwegian phonological system. It is shown the relation between stress and syllable length and stress alternations that may cause differences in the distribution of long and short vowels in related forms.

Chapter 2 presents basic theoretical assumptions of Government Phonology. The notion of empty categories is introduced and explained, as well as the mechanisms of government and licensing. Particular attention is paid to possible (allowed) syllabic structures and the so-called Binariness Theorem, which allows maximally binary structures. This chapter introduces also elements, i.e. phonological primes which are assumed to determine the internal composition of consonants and vowels.

Chapter 3 is devoted to the so-called „open syllable lengthening” in Icelandic and Norwegian. As it seems, an alternative definition of an open syllable is needed in order to explain long vowels in forms like given above. The traditional view on the syllable is confronted with Government Phonology’s assumption that every word-final consonant is in fact an onset of the following syllable. As every onset needs a licenser, word-final empty nuclei are introduced.

Chapter 4 discusses branching onsets in Icelandic and Norwegian. An attempt is made to explain why forms like Ic. *sötr* [sœ:tʰr] or Norw. *Afrika* [a:frikʰa] have a stressed long vowel, although a consonant cluster follows. It is shown that some particular plosive+sonorant clusters constitute branching onsets, hence leaving the preceding syllable open and allowing the nucleus to branch. The discussion concentrates not only on phonological features that are common for Icelandic and Norwegian (i.e. branching onsets), but also on language-specific phenomena like preaspiration or the so-called stopness sharing in Icelandic. A side-glance is cast on the Faroese data which seem to support the analysis of branching onsets.

Chapter 5 further analyses the distribution of long and short vowels and continues the discussion on Icelandic preaspiration. Both melodic and structural interpretation of preaspiration is proposed and its influence on the preceding nucleus.

Chapter 6 sheds some alternative light on the so-called retroflex consonants in Norwegian. The consonants in question show considerable variation with respect to the length of the preceding vowel. The government-based analysis shows again that despite the phonetic realization of the retroflex consonants (which are pronounced as short), they should be treated as geminates, resulting from the left-spreading of the coronal element A.

Chapter 7 takes a closer look at what was traditionally called coda-onset contact. Particular attention is paid to geminates, i.e. long consonants that can be found both in Icelandic and Norwegian. It is shown that geminates occur both word-internally and word-finally, the latter being virtual (phonological but not phonetic) geminates. In this context the licensing abilities of word-final nuclei are compared to the ones of full vowels.

Chapter 8 analyses the peculiar phonological behavior of /s/ in Icelandic. As it seems, this consonant behaves as a sonorant (i.e. governee) in some contexts, but as a head (governor) in others. Following GUSSMANN (2001a) we call it “the double agent” of Icelandic phonology.

Chapter 9 is devoted to the phonology of quantity in compound words in Icelandic. An attempt is made in order to demonstrate that the general rule that governs the distribution of long and short vowels in simplex forms applies also compounds and derived forms. Again, there will be shed some more light on the specific behavior of /s/.

Chapter 10 analyses the creation of past tense in Icelandic and Norwegian from the phonological point of view. As it seems, the two languages apply different strategies in this respect. In Icelandic, the creation of past tense is purely phonological and derives from the general rule of the coda-onset contact (hence the distribution of long and short vowels in the past tense is precisely the same as in the infinitive). In Norwegian the situation is far more complex and important differences between the base form of the infinitive and the form in the past tense can be found. An alternative analysis of the past tense in Norwegian is proposed, base on the interaction between phonology and morphology. The role of the tonal element H in the creation of past tense in both languages is stressed.

It my pleasure and a great honor to express my deepest gratitude to various people whose constant support, devotion and encouragement were invaluable during the writing of this thesis. I owe special thanks to the late Professor Edmund Gussmann, who laid the foundations for my interest in phonology and who was my first Ph.D. supervisor. I also feel deeply indepted to Professor Grzegorz Skommer, my supervisor, for his constant patience, professional criticism and detailed comments on my thesis. Often I had the feeling that he kept his faith in me while I was in despair. Many thanks are due to Professor Eugeniusz Cyran

for many (not only) phonological discussions in Reykjavík, Lublin and a couple of other towns. I benefited considerably from Jarosław Aptacy, Ph.D. with whom I had the pleasure to discuss many linguistic issues. I owe many thanks to Katarzyna Petryniak, Ph.D., for her enormous effort to make my English readable. And last, but not least – to Mr Piotr Jankowiak for his encouragement and simply for being there, when there was no one else.

Chapter 1. Sounds of Icelandic and Norwegian

Below we present a sketch of the vowel and consonant inventory of Icelandic and Norwegian. Although no phonological analysis can be dispensed of at least some portion of phonetic data, it should be clearly born in mind that in principle the lists of vowels and consonants have a very limited value for phonology. Government Phonology differs from many other theoretical approaches in that it states that phonological processes are solely phonologically motivated.² As explicitly observed in GUSSMANN (2004: 24), “phonetic notions are not given in advance, while the gymnastics of the speech organs and the ensuing acoustic signal can be dissected in numerous ways. Most of these possible dissections are linguistically

irrelevant, voice quality being a trivial but straightforward case”. Sounds as such (in the meaning of phonetic segments) can say very little, if anything, about the phonological system of a language; thus, the following presentation should be treated with a secure distance and only as a starting point for any further analysis. Moreover, since the main concern in the dissertation is the phonological system of Icelandic and Norwegian, some irrelevant phonetic details will be omitted as inessential to our analysis. The reader interested in the phonetic descriptions of the languages in question is referred to the numerous works taking up this issue (see e.g. BALDUR RAGNARSSON (1978), EIRÍKUR RÖGNVALDSSON (1990a) and (1990b), INDRIÐI GÍSLASON and HÖSKULDUR ÞRÁINSSON (1993), KRISTJÁN ÁRNASON (1980), MAGNÚS PÉTURSSON (1976) and (1978) for Icelandic, and ENDRESEN (1984), POPPERWELL (1963), TORVIK (1979), STRANDSKOGEN (1997) for Norwegian).

1.1 Vowels

Let us start with a presentation of the vowel inventory of Icelandic and Norwegian. As well-known, vowels can be classified as follows (see e.g. Ladefoged⁵ 2006: 18ff):

- by the part of the tongue which is highest in relation to the roof of the mouth - as front, central, back,

² The opposite view, namely that phonological processes are phonetically motivated, seems to have dominated the phonological debate for decades. The phonetic causality of phonological regularities is one of the crucial assumptions of Grounded Phonology (ARCHANGELI and PULLEYBLANK 1994) or Natural Phonology (DZIUBALSKA-KOŁACZYK 2012, *passim*), to name just two.

- by the position of the lips - as rounded (close or open lip rounding) or unrounded (spread or neutral lip position); as close, half – close, half – open, open,

- by the size of the opening between the tongue and the roof of the mouth

According to the above criteria, the vowel system of Icelandic can be sketched in the following way (GUSSMANN 2002a: 158):

- front, high, unrounded [i], e.g. *síða* [si:ða] (side)
- front, mid, unrounded [ɪ], e.g. *síða* [sɪ:ða] (bring up)
- front, mid, rounded [ɥ], e.g. *suður* [sɥ:ðɥr] (south)
- front, low, unrounded [ɛ], e.g. *seðla* [seðla] (fill)
- front, low, rounded [œ], e.g. *söðla* [sœðla] (saddle)
- back, high, rounded [u], e.g. *súpa* [su:p^ha] (soup)
- back, mid, rounded, [ɔ], e.g. *sonur* [sɔ:nɥr] (son)
- back, low, unrounded [a], e.g. *saga* [sa:ɣa] (saga, story)

In addition to the monophthongs above, there are five diphthongs [ei, ai, au, ou, œi], as in the following words: *heyirn* [heirtn], *vætla* [vaihtla] (drip), *átta* [auhta] (eight), *ótti* [ouhti] (fear), *austur* [œistɥr] (east). Additionally, MAGNÚS PÉTURSSON (1976: 44f.) and (1978:45f.) discusses the diphthongs [oi, yi, ii, ui] as appearing in Icelandic but he excludes them from the set of Icelandic diphthongs because of their very limited distribution (they occur only when preceding the glide [j]).

In comparison, the vocalic system of Norwegian can be presented as below (POPPERWELL (1963: 12–14), KRISTOFFERSEN (2001: 13–18)):

- front, unrounded vowels: [i], [ɛ], [æ], e.g. *bil* [pi:l] (car), *belje* [pɛljə] (gulp), *berge* [pærkə] (rescue)
- back vowels: [a], [ɔ], e.g. *ball* [paɪ] (ball), *bånd* [pɔn] (string, band)
- central vowels: [u], [ə], e.g. *bord* [pu:r] (table)
- front rounded vowels: [y], [œ], [ɥ], e.g. *synd* [syn] (sin), *sønn* [sœn] (sun), *sunne* [sɥn] (healthy)

Apart from the above monophthongs there are three diphthongs in Norwegian:

[æj] - *vei* [væj] (way)

[œj] - *røyk* [rœjk^h] (smoke)

[æw] - *sau* [sæw] (sheep)

The three diphthongs above are regarded as common. In addition, there are also three marginal diphthongs, which only occur in a few words of foreign origin:

[ɔj] - *koie* [k^hɔjə] (shanty)

[uj] - *huie* [hujə] (shout)

[aj] - *hai* [haj] (shark)

Both some of the Icelandic and Norwegian sound segments require additional comments. First of all, there is no absolute agreement in the phonetic description of Icelandic vowels. The presentation in (1) has been based on GUSSMANN's account (GUSSMANN 2002a: 158). EIRÍKUR RÖNGVALDSSON (⁴2002: 46), on the other hand, mentions only one low vowel in the Icelandic system, namely [a]. According to his analysis, [ɛ] is a mid vowel, [ɪ] is between high and mid and [œ], (transcribed by Eiríkur as [ö]), is placed in between mid and low. In INDRÍÐI GÍSLASON and HÖSKULDUR ÞRÁINSSON (1993: 34), however, one can find four low vowels [ɛ, ö, a, ɔ]. As far as Norwegian is concerned, the front, unrounded vowel [æ] has a very limited distribution and it is regarded by KRISTOFFERSEN (2000: 14) as a marginal phoneme. Indeed, [æ] occurs only before [r] and the two glides [j] and [w].

Furthermore, there is a principal difference between Icelandic and Norwegian diphthongs. In the former language, both monophthongs and diphthongs can occur as short or long, according to some very strict principles of the syllabic structure in Icelandic. Typologically, this is a rather rare feature; within the Germanic family only Faroese, a language related most closely to Icelandic, shares it. In Norwegian, diphthongs are regarded as long.

Finally, both in Icelandic and Norwegian there occurs a slight difference between the pronunciation of short (unstressed) and long (stressed) vowels. Although it has been generally assumed that there is no difference in the quality of the stressed and unstressed vowels in Icelandic (see SVEINN BERGSVEINSSON 1941: 81), PÉTUR HELGASON (1993:26f.) claims that the unstressed vowels have a somewhat different place of articulation and are

slightly centralized. Also for Norwegian KRISTOFFERSEN (2000: 11) thinks it possible to use different symbols to denote short and long vowels in stressed syllables. This differentiation can be ascribed to the notion of tenseness, as is generally done in the phonological literature on e.g. English or German, where vowel tenseness plays a central role. Consequently, no difference in the quality of short and long vowels will be taken into consideration here.

1.2. Consonants

The consonant inventory of Icelandic consists of the following sound classes:

(3) a. plosives:

- bilabial [p, p^h]
- alveolar [t, t^h]
- palatal [c, c^h]
- velar [k, k^h]

b. fricatives

- labio-dental [f, v]
- dental/alveolar [θ, ð, s]
- palatal [j, ç]
- velar [x, ʁ]
- glottal [h]

c. sonorants

- nasal [m, n, ŋ]
- lateral [l]
- trill [r]

The consonant inventory of Norwegian is given in the table below (see KRISTOFFERSEN (2001: 22)):

Table 1.

	Bilabial/ labiodental	Dental/ alveolar	Retroflex	Palatal	Velar	Laryngeal
Stops	p ^h , p	t ^h , t	ṭ ^h , ṭ		k ^h , k	
Nasals	m	n	ɳ		ŋ	
Fricatives	f	s	ʂ	ç		h
Liquides		r, l	ɽ, ɺ			
Approximants	v, w			j		

The consonant system sketched above requires a few words of clarification. It is not only the matter of transcription, but also a problem with far-reaching consequences for the phonological analysis as a whole. In the following pages an attempt will be made to apply the broad IPA transcription system outlined in the *Handbook of the International Phonetic Association* (1999). This system has not always been used in the Icelandic and Norwegian phonetic tradition. Especially for older works on Norwegian phonetics and phonology, there dominated a tradition to use the Scandinavian model of phonetic transcription (based on both Norwegian, Danish and Swedish convention), i.e. the so-called *Norvegia* transcription, a conventional system proposed by Johan Storm in the second half of the nineteenth century (see STORM 1882 and a discussion of the proposal in KOLSRUD 1950 and SELMER 1952). Even now there is no absolute agreement as for the use of the IPA phonetic symbols for Icelandic and Norwegian and particular approaches differ in this respect.

As was said above, the adherence to a particular transcription system may heavily influence the very analysis; e.g. both in Icelandic and Norwegian there are no voiced plosives [b, d, g]. Consequently, as there is no voiced–voiceless contrast in the series of plosives, the only difference between the spelled *p, t, k* on the one hand and *b, d, g* on the other hand is that of aspiration. At least in the past twenty years most of the scholars working on Icelandic have decided to use the symbols [p^h, t^h, k^h] in order to denote the historically voiceless plosives, and [p, t, k] to transcribe the historically voiced plosives³. Nevertheless, this has never been done for Norwegian. Like in Icelandic, the contrast between the Norwegian series *p, t, k* and

³ However, most of the standard textbooks on Icelandic consequently use the symbols [b, d, g] for the historically voiced series (e.g. STEFÁN EINARSSON 1949, BALDUR RAGNARSSON (2)1973), KRISTJÁN ÁRNASON (1980b), to name just a few. As it seems, this is quite a peculiar way of denoting the voicelessness of these consonants, since the reading of, e.g. the symbol [b] would be ‘a voiceless [b]’.

b, d, g is not that of voicing (as in e.g. Romance or Slavic languages), but rather it implies the presence or the lack of aspiration, respectively. This has been rightly noticed in SIVERTSEN (1967: 74ff.), although her observation is not reflected in the transcription applied in her book. The most comprehensive phonology of the language (KRISTOFFERSEN 2000) follows the general tradition of using the voiced symbols, although the author himself states that the traditional voiced plosives are only partially voiced in Norwegian and that in this respect Norwegian seems to be prototypically ‘Germanic’ (KRISTOFFERSEN 2000: 74f.). To avoid the confusion and to conform the transcription of Norwegian data to the Icelandic one, we decided to use the same symbols for both languages. One more reason for such a decision will be mentioned in chapter 5 which will be devoted to aspiration and preaspiration in Icelandic.

Another important observation which is directly connected to what has been said above concerns the Icelandic and Norwegian sonorants. As described in detail in every textbook on Icelandic, Icelandic sonorants are pronounced either voiced or voiceless, depending on the environment they appear in. They are voiced word-initially⁴, between vowels and before the historically voiced plosives (4a), but unvoiced when they appear before *p, t, k* and *s* (4b). Consider the following examples:

(4) a. tala [t^ha:la] (talk)

maður [ma:ðʏr] (man)

lamb [lamp] (lamb)

orga [ɔrka] (scream)

b. lampi [lampɪ](lamp)

orka [ɔrka] (affect, influence)

mjólk [mjoulk] (milk)

vanta [vanta] (lack)

For Icelandic, the literature has been consistent in using the IPA symbols for voiceless sonorants. For Norwegian, on the other hand, there is no such a practice; hence, even in the most contemporary accounts on the phonology of the language, voiceless sonorants are transcribed as voiced (e.g. KRISTOFFERSEN 2000, with an exception in chapter 4.2.1, p.

⁴ Apart from sonorants preceded by the *h* in the spelling, which can be analysed as a single segment, i.e. voiceless sonorants; HÖSKULDUR THRÁINSSON 1981, however, opts for treating the voiceless sonorants as underlying /hl/, /hr/, /hn/ on the basis of alliteration.

76)⁵. Still, the phonological behaviour of Norwegian sonorants is exactly the same as of those in Icelandic, as the following pairs of examples illustrate:

(5) ark [ˈɑrk] (sheet)	arg [ˈɑrk] (indignant)
salto [ˈsɑltu] (summersault)	saldo [ˈsɑltu] (balance)
kreve [kre:və] (demand)	greve [kre:və] (count)
plass [pl̥as] (place)	blass [pl̥as] (pale)

Again, for reasons given above, we will uniform the phonetic transcription for Icelandic and Norwegian and consistently mark the voicelessness of the sonorants.

1.3. A note on stress and its relation to vowel length

As will be shown in the following sections, the general quantity rule in Icelandic and Norwegian is quite simple and follows from the strict adherence to the syllable structure. In other words, all stressed syllables are long (heavy, bimoraic), and all unstressed ones are short (light). According to this rule, the contrast short–long can only be found in stressed syllables. This assumption connects vowel length with its stress. As well-known, Icelandic and Norwegian differ in that the former one is deprived of the so-called melodic accents (Norwegian *tonemer*), realised as two different, contrastive pitch contours, also called accent 1 (*tonem 1*) and accent 2 (*tonem 2*) (see KRISTOFFERSEN 2002: 11 and, especially, chapters 9 and 10). Obviously, the pitch accent has no significance for the phonology of quantity in Norwegian. Therefore we will omit the melodic accents both in the analysis which follows and in the transcription of particular word forms. What has a direct impact on the length of the vowel is the word stress, i.e. the relative prominence of a syllable. The stress pattern in Icelandic is quite simple as the primary stress of simplex words always falls on the first nucleus (initial stress) while the secondary stress - on every second vowel counting from the initial primary stress, unless the vowel is an inflectional ending (KRISTJÁN ÁRNASON 1980: 45, 1992: 11, GUSSMANN 1985: 78). Although the situation in Norwegian is far more

⁵ ENDRESEN (1984: 57f.) is a positive exception in that a clear distinction between voiced and voiceless is made both in the phonemic description of Norwegian sound system and in the phonetic transcription which ENDRESEN (1984) applies. Also KRISTOFFERSEN (1982) discusses at large the problem of sonorant devoicing in Norwegian, which he calls ‘progressive assimilation’. However, as we said above, he does not decide to apply this convention systematically in his latest book (2000).

complex, i.e. the stress cannot be automatically ascribed to a concrete nucleus in a word (especially when morphology is in play), one can formulate a general statement that it is the root syllable that carries the primary stress ('stress the leftmost syllable of the root', see KRISTOFFERSEN 2002: 148, where one also finds a discussion on the problems connected with the notion "root syllable"). In the following pages we will mark stress in all Norwegian words, leaving stress in Icelandic unmarked.

As was said above, tone, stress and vowel length are in a direct relationship with one another. In HAUGEN (1967), we find a hierarchy of those three categories of quantity, stress, and tone:

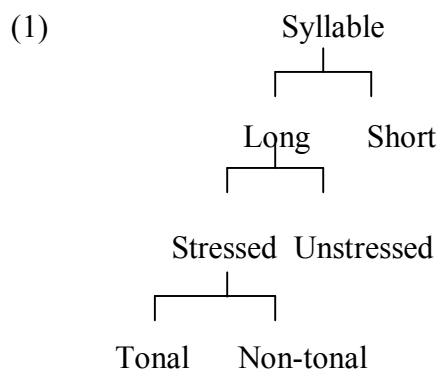

The above picture demonstrates clearly that the stressed nucleus must always be taken into consideration in the discussion on vowel length. Furthermore, different stress placement may result in vowel length alternations, as illustrated below in some Norwegian examples (the stressed vowels are underlined):

- (2) *drama* [tra:ma] (drama) vs. *dramatisk* [trama:tisk] (dramatic)
balsam [palsam] (balsam) vs. *balsamisk* [palsa:misk] (balmy)
protest [pru^hɛst] (protest) vs. *protestere* [pru^hɛstɛ:rə] (protest)

KRISTOFFERSEN (2000: 19) notes furthermore that, under stress shift, the short and long vowels define corresponding pairs in such a way that when a syllable with a long vowel loses its stress, the vowel is reduced to the corresponding short vowel.

In Icelandic, as pointed to me by KRISTJÁN ÁRNASON (p.c.), a similar relationship between stress and vowel length can be established. Although stress placement in Icelandic is fixed and the primary stress always falls on the initial syllable, in emphatic speech any other

syllable can bear stress, making the vowel long (examples from KRISTJÁN ÁRNASON 2005: 204):

- (3) a. Már er kominn HEIM [maurɛrk^hɔmm^hei:m] (Már has got HOME)
b. MÁR er kominn heim [ˈmau:rɛrk^hɔmm^hheim] (MÁR has got home)

The above generalisation about stress as one of the factors determining vowel length has been formulated on the ground of classical generative phonology in terms of a hierarchy which in the prosodic organisation of both Norwegian and Icelandic ranks stress above length (for a discussion on the basis of Norwegian data see FRETHEIM 1969).

Chapter 2. The main assumptions of the theoretical framework

The phonological model adopted in this dissertation is the one of Government Phonology, starting with some pioneering works in the eighties and the more regular model-founding articles by KAYE, LOWENSTAMM and VERGNAUD (1985, 1989, 1990), CHARETTE (1991), BROCKHAUS (1995), HARRIS (1990, 1994, 1997), HARRIS and GUSSMANN (1998), HARRIS and LINDSEY (1995) and developed by CYRAN (1997, 1998), GUSSMANN (2002a), GUSSMANN and CYRAN (1998), with the so-called CVCV phonology offshot, represented e.g. by CYRAN (2003) and SCHEER (1998a, 1998b, 2004). Although inferior to other post-generative frameworks like Optimality Theory, the literature on Government Phonology is quite rich; for a detailed discussion and revisions of the model the reader is referred to the works mentioned above. In the following pages we will limit ourselves to the issues that are directly relevant for our analysis of vowel length. Below we present some fundamental assumptions of the model adopted here, leaving more detailed discussion to particular sections devoted to problems such as constituency, melody merger, domain structures and others.

First of all, Government Phonology is a non-derivational framework; hence, any discussion about phonological rules is sounds irrelevant. In other words, Government Phonology makes no distinction between underlying and derived representations. It also implies that there is no possibility of resyllabification, as it was posited by classical generative phonology. Whether a segment associates with a syllable onset, nucleus or a coda is not a mechanical procedure, but rather the effect of an analysis of any possible sound combination in a given language. What appears at the beginning of a word is not necessarily an onset; consequently, not every word-final consonant combination qualifies as a possible coda. Furthermore, Government Phonology strictly rejects the coda as a separate syllabic constituent. In Government Phonological terms, what has been classified as a coda is simply a rhymal complement which has to be licensed by the following onset. Consequently, there are no word-final codas. If a word terminates in a single consonant, the consonant is automatically assigned to the position of the onset, being licensed by the following empty nucleus. Languages vary in that some of them allow word-final onsets to be licensed by the empty nucleus, while others do not. In the literature this fact has been known as the so-called *word-final empty nucleus parameter*, which is switched on in such languages as Icelandic and

Norwegian and switched off in e.g. Italian, where all words terminate in a phonetically realised vowel.

By means of the above assumption we introduce the so-called empty categories, a feature which current linguistic theories make an extensive use of, especially in the field of syntax, but also in different phonological frameworks. In Government Phonology, one recognises empty onsets and empty nuclei, but especially the latter play a prominent role in the phonological organisation of syllabic constituents. We will come back to this issue later on.

The phonological hierarchy recognised by Government Phonology consists of three, partially independent, levels of organisation. The syllabic level is built up of sequences of onsets and rhymes (both of which can be simple or branching) which are then associated with the melodic level through the skeletal (timing) level of x-slots. The partial independence of the syllabic and melodic level results from the fact that the former is not a projection of the latter. Hence, the presence of e.g. an onset does not necessarily imply the presence of a melody attached to it. What is, furthermore, crucial for this model of phonological organisation is the fact that Government Phonology rejects the need of the syllable as a separate unit⁶. Since all phonology is done on the melodic or the constituent level, there is no need to recognise additional level in the phonological hierarchy. Paradoxically, the terms “syllable” and “syllabic” seem to be widely used in the Government Phonological literature. However, both in other works on Government Phonology and in the following dissertation, the term “syllable” is to be understood as a synonym of the onset, rhyme or nucleus.

It was said above that what appears at the beginning of the word does not necessarily qualify as an onset. Similarly, the same can be said about the right edge of the word. According to the Binariness Theorem, in Government Phonology constituents can be maximally binary; this assumption drastically constrains the possible consonant combinations which can be considered either as well-formed onsets or well-formed codas. Schematically, the possibilities provided by the theory are the following:

⁶ In this respect Government Phonology shares its view with the so-called Beats-and-Binding phonology, as outlined in e.g. DZIUBALSKA-KOŁACZYK (1995 and 2002).

(1) a. Simple onset



b. Branching onset

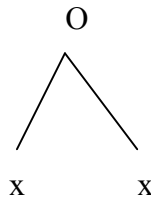

c. Simple rhyme (=non-branching nucleus)



d. branching rhyme (= branching nucleus)

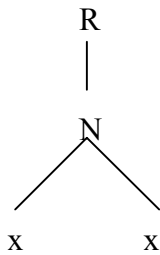

e. Branching rhyme (= non-branching nucleus and a rhymal complement)

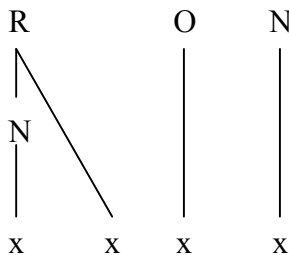

The terms ‘branching’ and ‘non-branching’ relate to the the number of skeletal slots on the timing tier dominated by a constituent. Hence, a simple onset is assigned to one skeletal position while a branching onset occupies two timing slots. Similarly, a simple, non-branching nucleus (i.e a short vowel or a short diphthong) associates with one x-slot, and a branching nucleus (i.e. a long vowel or a long diphthong) ascribes to two timing positions.

A branching onset is a governing domain, consisting of a governor (the stronger consonant) and a governee (the weaker one). It is generally assumed that the left-hand member of the onset is the governor and the right-hand - the governee. In order to qualify as a well-formed branching onset the two consonants in question must fulfil strict complexity requirements i.e. the governor must be more complex than the governee⁷. Similarly, a coda-

⁷ Segmental complexity resembles to some extent the sonority scale well-known from classical phonological literature, whereas the more sonorous segment in the traditional terms is less complex (or weaker) in the terms of Government Phonology. For a more detailed discussion cf. CHARETTE (1991) and HARRIS (1994).

onset juncture (as depicted in (1e.)) also constitutes a governing domain, but here it is the right-hand member of the domain (the onset) that is the governor (the stronger consonant), whereas the left-hand member (the rhyml complement) is the governee (the weaker consonant).

Another crucial point about the theoretical assumptions of Government Phonology (the one which runs against most of the contemporary phonological theories and much of the phonological tradition in general) is the fact that Government Phonology operates in strictly phonological contexts, i.e. that phonetics plays a highly limited role in any phonological analysis. Basing phonological generalisations on phonetic observations has led different theoretical frameworks to often dramatically incorrect and misleading conclusions. To avoid such failures, Government Phonology insists on treating phonetics as (partially) irrelevant for describing the phonological system of a language. In other words, the phonetic properties of a vocalic or consonantal segment are secondary towards its phonological behaviour and the position it occupies in the phonological system (a number of interesting case studies devoted to this issues are accessible in GUSSMANN (2001), (2004a) and (2004b)).

The above statement about the very limited role of phonetics does not mean that Government Phonology (or any other phonological framework) is able to dispense totally of phonetic facts: phonetics should rather be understood as a supplement to phonological theoretical devices. In this sense Government Phonology does not follow the tradition of the classical generative phonology, which worked with phonetically based distinctive features, but, instead, adopts a restricted number of monovalent melodic primes, which are called elements. In the literature, depending on the theory and its tradition, one can also find the terms: features, gestures or particles (see HARRIS 1994: 90). The element theory, a sub-theory of Government Phonology (see especially HARRIS 1994, HARRIS and LINDSAY 1995 and BLOCH-ROZMEJ 2008), is a subject of constant revisions and attempts at restricting the number of primies. According to this theory, both vowels and consonants are componential. They can be composed either of a single element (a simplex expression) or of a fusion of two or more elements (a compound) (HARRIS 1994: 96). The same symbol can be used to describe the melodic property of a consonant or a vowel. In this dissertation the following elements will be adopted (see also KAYE, ms.):

(2) {A} (openness for vowels; coronality for consonants)

{I} (fronteness for vowels; palatality for consonants)

{U} (rounding for vowels; labiality for consonants)

{h} (noise)

{N} (nasality)

{L} (low tone and voicedness)

{H} (high tone and voicelessness)

{ʔ} (occlusion)

In the tables below, the elements mentioned so far are provided with detailed phonetic properties they define (see BLOCH-ROZMEJ 2008: 31):

(3) Vocalic elements

PRIME	ACOUSTIC PATTERN	ARTICULATORY PATTERN
I	Dip: low F1 with high spectral peak (convergence of F2 and F3)	Maximal constriction of oral tube, maximal expansion of pharyngeal tube
U	Rump: low spectral peak (convergence of F1 and F3)	Trade-off between expansion of oral and laryngeal tubes
A	Mass: central spectral energy mass (convergence of F1 and F2)	Maximal expansion of oral tube, maximal constriction of pharyngeal tube

(4) Elements for consonants

PRIME	ACOUSTIC PATTERN	ARTICULATORY PATTERN
ʔ	Edge: abrupt and sustained drop in overall amplitude	Occlusion in oral activity
h	Noise: aperiodic energy	Narrowed stricture producing turbulent airflow
N	Nasal: low frequency of first resonance, broad resonant peak at lower end of the frequency range	Lowered velum: airflow through the nasal passage
H	High tone: raised pitch on vowels; VOT lag (aspiration) in obstruents; high fundamental frequency	Stiff vocal cords
L	Low tone: lowered pitch on vowels; VOT lead (full voicing) in obstruents; low fundamental frequency	Slack vocal cords

A combination of the above elements can produce more complex expressions in which one of the elements may occupy the position of the head of the expression and the other (or others) will act as operators. The head can be empty as well, producing e.g. a lax vowel or a velar consonant.

Naturally, the more complex the expression, the stronger its position in the syllable structure. We can, then, follow Kaye (ms.) in formulating the complexity condition:

An expression x may govern an expression y if $N_x \geq N_y$ (where N = the number of features in the expression).

The consonant in the onset must be therefore stronger than its governee - the consonantal coda. As well-known, the very concept of consonantal strength is not any novelty in the phonological tradition (see FOLEY (1977) or VENNEMANN (1972) for an exhaustive discussion on the idea within the framework of the classical generative phonology).

Chapter 3. Quantity in Icelandic and Norwegian – “open syllable lengthening”

Quantity is a prosodic feature which is perhaps the major focus research in Scandinavian linguistics. The suprasegmental systems of the North Germanic languages are structurally complex and include features infrequent elsewhere in Europe (ELIASSON 1985: 101).

As far as phonological contributions to the phonology of Icelandic are concerned, quantity and the connected problems have been a central issue and have long attracted attention of scholars, both in Iceland and abroad. From the considerable number of contributions devoted to Icelandic quantity only some of the most influential, challenging, controversial, innovative or ground-breaking works on this issue will be mentioned below: e.g. KRISTJÁN ÁRNASON (1978), (1980a) and (1998), GARNES (1976), MALONE (1953), SVEINN BERGSVEINSSON (1941), HAUGEN (1958), HREINN BENEDIKTSSON (1963), LIBERMAN (1982), GUSSMANN (1985), (2001b), (2002a), (2006a) and (2006c). Several descriptions of the phenomenon (mostly general in nature) are also available in textbooks on Icelandic (e.g. STEFÁN EINARSSON 1949) and phonetic and phonological descriptions of the language, c.f. EIRÍKUR RÖGNVALDSSON (1990a) and (1993) and INDRÍÐI GÍSLASON and HÖSKULDUR ÞRÁINSSON (1993). Most recently, KRISTJÁN ÁRNASON has written an impressive and the most comprehensive phonological analysis of the language that has ever been published (KRISTJÁN ÁRNASON 2005). The book, the first volume of a monumental three-volume set of handbooks on Icelandic, devotes a considerable space to the problem of quantity in the language, both in its diachronic and synchronic aspect.

The number of significant contributions for the Norwegian language is far less impressive than that for Icelandic, as can be generally said about the phonological works on the language (see KRISTOFFERSEN 2000: 10). A representative collection of papers devoted to different fields of the phonetics and phonology of Norwegian can be found in JAHR and LORENTZ (ed.) (1981) and (1983), out of which HAUGEN (1942), BORGSTRØM (1938) and (1947), FINTOFT (1961), KLOSTER-JENSEN (1961), VANVIK (1969), FRETHEIM (1969) are particularly worth mentioning. A number of very general remarks on the quantity system of Modern Norwegian can also be found in introductory

books on Norwegian (HAUGEN 1937) and Norwegian phonetics in particular (e.g. POPPERWELL 1963, STRANDSKOGEN 1979).

A common conclusion for most of the works mentioned above, referring both to Icelandic and Norwegian, is the fact that in these two languages stressed syllables must be long (heavy). In the interpretation of Government Phonology a long syllable means simply a branching nucleus or a simple, non-branching nucleus followed by a rhyml complement. Below we present the three possibilities of stressed syllable structure in Icelandic and Norwegian:

(1) a. (C)V: C, e.g. Nor. *pen* [p^he:n] (pretty), *tak* [t^ha:k^h] (roof), *streve* [stre:və] (to struggle), *møte* [mø:t^hə] (to meet); Icel. *bók* [pou:k^h] (book), *kjöt* [c^hœ:t^h] (meat)

b. (C)V:, e.g. Nor. *bo* [pu:] (to live), *sta* [sta:] (stubborn), *ku* [k^hu] (cow); Icel. *á* [au:] (river), *ná* [nau:] (to get)

c. (C)VCC (where CC may stand for a geminate or a combination of consonants), e.g. Nor. *land* [lan] (land), *kast* [k^hast] (throw), Icel. *pabbi* [p^hap:i] (daddy), *kampur* [k^hampr] (camp)

This means that in Icelandic and in Norwegian (as in Faroese and most Swedish dialects), long vowels occur in stressed syllables in front of single consonants (1a), in front of hiatus and in the word-final position (1b), while short vowels under stress appear in front of two or more consonants and also in front of geminates (long consonants) (1c).

As concluded by SVEINN BERGSVEINSSON for Icelandic (SVEINN BERGSVEINSSON 1941), (and the same holds for Norwegian), the difference between the distribution of long and short vowels lies in the nature of the contact with the following consonant or consonants. Obviously, there is a reciprocal dependence between the vowel and the consonant length within the syllable, i.e. a long vowel is followed by a short consonant and vice versa (FOX (2002: 21)). This generalisation allows us to formulate a general quantity rule which says that vowel length is not contrastive either in Icelandic or in Norwegian. Therefore, when listing vowel segments in those two languages, one should limit the presentation to short vowels, since long vowels occur only under stress and under the strict conditions on the structure of the syllable.

We will now examine the precise nature of the syllable structure in (1a) and (1b). In our analysis especially the former runs against the mainstream of the phonological tradition. Examples in (1b) seem to be undisputable, since they display a structure which undoubtedly is an open syllable. The forms in (1a), although similar to the ones in (1b) with respect to vowel

length, are normally considered to represent closed syllables, since there the stressed vowel is followed by a consonant, occupying the coda position. Such an analysis will cause serious problems for any attempt of making generalisations about the distribution of long nuclei in Icelandic and Norwegian. In order to solve the problem a variety of proposals have been put forward. One of the most common theories in the phonological literature was the notion of extrametricality. It has been noticed that syllable margins (the so-called peripheral consonants) are in a way invisible to the metrical parse, and therefore have no influence on the quantity of the preceding vowel (see KENSTOWICZ 1994: 567 for a general description and KRISTOFFERSEN 1994 for applying the notion of extrametricality to the Nordic quantity rule). The same mechanism has been proposed for Icelandic in a number of case studies (see for instance KIPARSKY 1984, who assumes that word-final consonants are marked extrametrical by rule in the post-lexical component, or KRISTJÁN ÁRNASON 1998: 6 and 15). However, Government Phonology's view on word-final consonants is dramatically different from other phonological frameworks. As has been convincingly shown in several Government Phonology-based studies (see for example HARRIS and GUSSMANN 1998 or GUSSMANN and HARRIS 2002), every word-final consonant belongs in fact to the onset of the next syllable (with an empty nucleus licensing it). The forms, then, in (1a) and (1b) will all get the same description: they namely represent open syllables. That is why the presence of a long nucleus is completely unsurprising. We will now consider the representations for the Nor. *ku* [k^hʊ] (cow) in (2) and Icel. *bók* [pou:k^h] in (3):

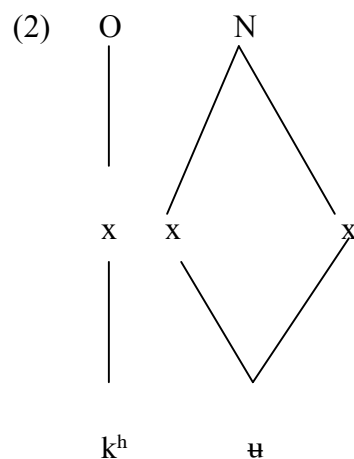

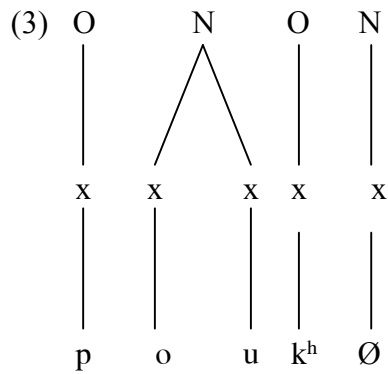

The main difference between those two forms lies in the number of nuclei. There is one branching nucleus in (2) and one branching and one non-branching empty nucleus in (3). The final aspirated plosive in the Icelandic form in (3) is therefore licensed by the domain-final empty nucleus, according to the domain-final empty nucleus parameter, which was discussed in chapter 2. However, as far as the stressed syllable is concerned, there is absolutely no structural difference: both syllables are open and, since there is no rhymal complement which could occupy the second x-slot in the branching rhyme, the stressed nucleus can branch. This is precisely what we find in all the forms in (1a) and (1b).

Both languages offer an almost unlimited number of forms with a branching nucleus in an open syllable like in the examples below:

(4) Nor. *spise* [spi:sə] (eat)

leve [lɛ:və] (live)

rope [ru:p^hə] (call out)

lage [la:gə] (make)

tyde [t^hy:tə] (interpret)

skrike [skri:k^hə] (scream)

røve [rø:və] (plunder)

måke [mɔ:k^hə] (shovel)

(5) Icel. *lita* [lɪt^ha] (color)

efi [ɛ:vɪ] (doubt)

skara [ska:ra] (poke)

nemi [nɛ:mɪ] (student)

móttíf [mou:t^hif] (subject)

gera [ʝɛ:ra] (do)

In all the forms above, the postvocalic consonant automatically assigns to the position of the onset; its natural consequence will be the long, branching nucleus in the preceding syllable.

The following chapter will illustrate some more interesting examples of open syllables in Icelandic and Norwegian and shed some light on the existence of branching onsets in these languages.

Chapter 4. Branching onsets in Icelandic and Norwegian

The traditional view on the syllable and its structure recognises every consonant cluster preceding the peak of the syllable (i.e. the nucleus) as an onset and every cluster which follows the nucleus as a coda (cf. FUDGE 1969, SELKIRK (1982). Generally, no reference to the number of the consonants in the clusters is made. It has been explicitly stated in many studies, from which we quote only one (CYGAN 1971: 13): “The initial and final clusters are immediately accessible as clusters appearing initially or finally in a stressed syllable of a word”

In other words, an onset can potentially consist of as many consonants as a language permits word-initially and consequently the same applies to the coda, i.e. word-final consonant clusters. Evidence from different languages shows that word-initial and word-final clusters can be quite complex (consider for instance the Polish forms *bzdura* [bzdura] (nonsense), *dżdżownica* [dʒdʒɔwnitsa] (earthworm)) (cf. GUSSMANN and CYRAN 1998 for a discussion of Polish initial consonant sequences within the framework of Government Phonology). The clusters in question break the so-called Sonority Sequencing Principle (cf. KENSTOWICZ 1994: 254f), which is recognized as determining the possibilities of consonant juncture and the syllable structure in general. It is generally agreed that sonority should increase towards the peak of the syllable and decrease from the peak to the right margin. The traditional analyses were not able to consider examples like the Polish ones. There emerged additional complications, e.g. the problem of consonants that do not fit into the stress pattern or the quantity system. To solve this problem the cross-theoretical marker of extrametricality has been introduced, which is, however, unconvincing and makes the phonological machinery more complicated than necessary.

As was already said, with the development of the so-called Principle and Parameters phonology or Government Phonology (as proposed by CHARETTE 1991, HARRIS 1994, KAYE et al. 1985 and 1989), the view on the syllable structure has been considerably modified. First of all Government Phonology broke with the claim that every word-initial consonant cluster has to be an onset and that every word-final cluster has to be a coda. Furthermore, according to the Binariness Theorem Government Phonology allows only maximally branching constituents; hence, a potential branching onset can only consist of two consonants. No branching codas are permissible, since a branching rhyme has only two skeletal slots. Either both of them are occupied by a branching nucleus (i.e. a long vowel) or

the first one is occupied by a vowel and the second one by the coda consonant (if, however, there is an onset which licenses the coda, according to the coda licensing principle, see KAYE 1990). Consequently, a word-final consonant can never be a coda, since there is no onset to license it. Instead of using the notion of extrametricality, Government Phonology claims that every word-final consonant is an onset of the next syllable which is licensed by the word-final empty nucleus (cf. GUSSMANN and HARRIS 2002, HARRIS and GUSSMANN 1998).

In the next chapter consonant clusters which can be potential branching onsets in Norwegian and Icelandic will be examined. It will be shown that only some of them can be qualified as such. The starting point of our discussion will be the lengthening of stressed vowels in these languages; it will help us to deal with the word-internal onsets. As we will see, this set of consonants is much more restricted than the one of the word-initial cluster.

4.1. Branching onsets in Norwegian

Word-initial consonant clusters in Norwegian are not as complex as the Polish ones and generally they follow the Sonority Sequencing Principle (with the exception of s+C clusters, which we will return to later on). The maximal number of consonants in the clusters is three; however, in every three-member cluster the voiceless sonorant /s/ is the first of them. For an extensive overview over consonant combinations in Norwegian see AWEDYKOWA (1972: 43ff) and (1975: 84ff) and KRISTOFFERSEN (2000: 46ff). Before we proceed with analysing particular consonant sequences, we will try to explain the requirements that a given consonant cluster has to fulfil to be classified as a branching onset. First of all one has to bear in mind that a branching onset (and every branching structure, in fact) is a governing domain. Hence, a well-formed branching onset must contain a governor, (which is the head of the onset) and a governee, (which is a dependent in the structure) (cf. HARRIS 1994: 168). Let us consider the following representation:

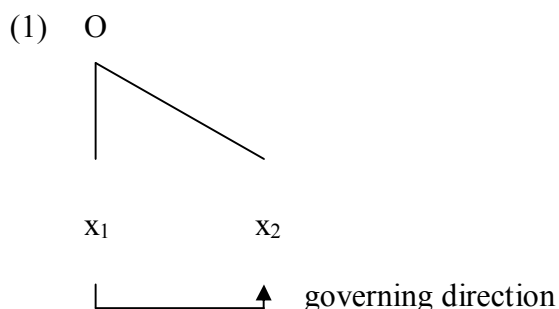

In (1) it is shown a representation of a branching onset. X_1 is the head of it, being the governor of x_2 , which acts as a governee. To be able to govern x_2 , x_1 has to be a consonant of greater complexity (note that the governing direction goes from left to right and cannot be reversed). It is generally agreed that a typical branching onset consists of an obstruent as a head and a sonorant as a governee. However, whether a sequence of two consonants conforms to the conditions of a branching onset or not is a question which can be answered only on the basis of language-specific data (GUSSMANN 2003: 322).

It is also assumed that the word-internal position is similar to the word-initial ones, which means that a given consonant cluster should be analysed in the same way both word-initially and word-internally (“once an onset, always an onset”).

In the preceding chapter we showed a number of forms with a long, i.e. branching nucleus when followed by a single consonant, which was occupying the position of the onset, leaving the syllable open. This, however, does not exhaust the environments where a stressed vowel in Norwegian can be long. Consider the following list of intriguing examples (cf. also POPPERWELL 1963: 110f for more data):

(2) *adle* [ˈa:tlə] (ennoble)

sabla [ˈsa:p̥la] (intensifying adverb)

bedre [ˈpɛ:trə] (to improve)

fagre [ˈfa:krə] (fair)

kapre [ˈkʰa:p̥rə] (capture)

kalfatre [kʰalˈfa:t̥rə] (caulk)

Abraham [ˈa:p̥raɦam]

ivre [ˈi:vrə] (enthuse)

høkre [ˈhœ:krə] (trade)

Afrika [ˈa:frikʰa] (Africa)

Although, obviously, the above examples are essential exceptions to the general quantity rule, which states that a long vowel can be followed by no more than one consonant, for some reason they have been largely ignored by phonologists working with the Norwegian sound system. In the literature one can scarcely find any interest in this set of intricate examples, which is particularly striking especially when one compares it to the descriptions of Icelandic, where examples like those above are given in literally every standard textbook and handbook. There arises a question whether we are dealing with real exceptions or if there is something else that, although a consonant cluster follows, determines branching of the nucleus. Therefore there certainly must be something which makes the consonant clusters special with respect to the length of the preceding vowel. We see that the second member of the clusters in (2) are the sonorants /r/ or /l/, which are generally assumed to be the weakest of the consonants, both in Icelandic or Norwegian. The set of the consonants being the first members of the clusters is definitely greater and contains both aspirated and non-aspirated stops and the voiced and the voiceless fricatives: /p^h, t^h, k^h, p, t, k, f, v/. At first sight, each of the clusters could be a potential branching onset. This can also explain why stressed vowels preceding the clusters are long: if those clusters are projected as onsets, the syllable is open and the vowel lengthens. However, this straightforward conclusion has to be verified on the basis of additional observations, which will be referred to in the next section.

4.2. Branching onsets or a sequence of simplex onsets?

Let us recall the clusters that cause the lengthening of the stressed vowel in Norwegian:

(3) /p_gr/, /t_gr/, /k_gr/, /p_l/, /p_r/, /t_l/, /t_r/, /k_r/, /v_r/, /f_r/

Remembering about the governing relations within a branching onset, we see that each of the clusters could meet the requirements for being a branching onset. The consonants in the first set are more complex than the sonorants in the second set; hence, they are able to govern them. It was also said that if a cluster is to be classified as a branching onset word-internally, it should appear word-initially. We see that the cluster /t_l/ does not appear among the clusters

that cause the vowel to lengthen (nor in the word-initial position). This hardly seems to be accidental and follows the Obligatory Contour Principle (cf. KENSTOWICZ 1994: 323ff). Hence, the sequence /t_l/ has to be excluded from potential branching onsets in Norwegian. Similarly, the cluster /tl/ never appears word-initially, although we saw that the vowel in the form *adle* is long. In fact, the consonants in the cluster /tl/ are not adjacent on the skeletal level, as they are separated by an empty nucleus. In *adle* the nucleus is silent, but it is phonetically realized in the noun *adel* and the adjectival form *adelig*. The conclusion is, then, that we are dealing with a bogus cluster. In the following representation the structure requires perhaps a more detailed explanation:

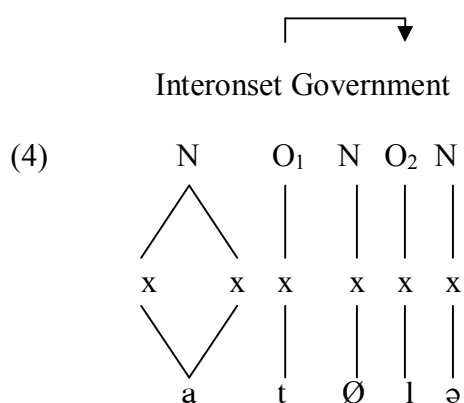

In this structure, namely, we introduce the so-called Interonset Government. The syllabification of the obstruent /t/ in the onset (O₁) is a natural consequence of the fact that the preceding vowel is long. As was shown on the basis of the related forms (the noun and the adjective), the sonorant /l/ is not adjacent to the obstruent, so it has to be assigned to another onset (O₂). O₁ and O₂ create a governing relation, where the first of the onsets governs the second one. This type of relation is called Interonset Government and is generally assumed to be left-headed (e.g. GUSSMANN and CYRAN 1998). In fact, the clusters /vr/ in the form *ivre* and /pl/ in *sable* are also bogus clusters, since they have related forms *iver* and *sabel*, which show that there is a vowel separating the two consonants. Therefore, a similar structure could be proposed for these two particular cases. Generally a sequence /vr/ is syllabified as a coda-onset juncture in Norwegian (eg. *havre* [havɾə] (oats)).

During the analysis we have excluded all the clusters where the second member is the sonorant /l/ and those where the second member is the /r/ (/vr/) from possible branching onsets in Norwegian. Although we concentrated on the word-internal clusters, a general assumption is that the clusters should be analysed in the same way also in the word-initial position.

Among the clusters that are not branching onsets word-internally, only three appear word-initially: /p̥l̥/, /pl̥/ and /vr̥/, eg. *plante* [p̥l̥aŋtə] (plant), *blande* [p̥lan:ə] (to mix), *vrake* [vra:kə] (to discard). We think it is a reason enough to suspect that also in this position these sequences do not constitute a single branching structure, but rather a sequence of two onsets split by an empty nucleus. Consider the following representation of the forms *sable* and *blande*:

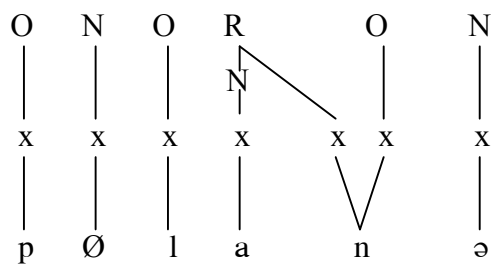
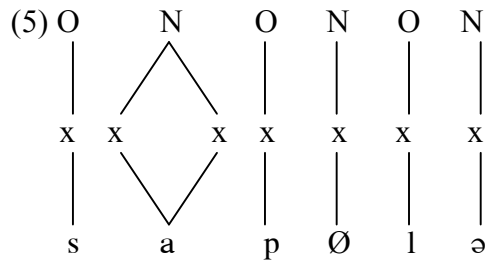

The clusters we are left with all have /r/ as a second member: /p̥r̥/, /t̥r̥/, /k̥r̥/, /p̥r̥/, /t̥r̥/, /k̥r̥/, /f̥r̥/. They appear word-initially (eg. *pris* ['p̥ri:s] (price), *tre* ['t̥r̥e:], *krangle* ['k̥raŋlə] (pick a quarrel), *bror* ['p̥ru:r] (brother), *dra* ['tra:] (pull), *granske* ['k̥ranskə] (investigate), *fred* ['f̥r̥e:t] (peace)) and, as the data reveal, they do not have any cognate alternating forms,[?] which would suggest that there is an empty nucleus separating the consonants. It seems, therefore, that they are the genuine branching onsets in Norwegian.

Let us now summarise this discussion. The examples in (2), all of which contain consonant sequences lengthening the stressed vowel can actually be divided into two groups: forms with bogus consonant clusters (where the consonants are not adjacent at the skeletal level because an empty nucleus separates them) and forms with genuine, well-formed branching onsets. The following inspection of word-initial consonant sequences seems to support these conclusions.

4.3. Word-initial consonant clusters

Word-initial consonant clusters in Norwegian can be made up of at most three consonants. However, in every three-consonant cluster, the first consonant is invariably the spirant /s/ followed by what could potentially be a branching onset: *skrive* [skri:və] (to write), *språk* [sprɔ:k] (language), *strid* [stri:] (conflict), *sklave* [skla:və] (slave). Government Phonology claims that the spirant /s/ can never constitute a branching onset with another consonant (see KAYE 1996 for an exhaustive discussion). In other words, the spirant can never act as a governor in a branching structure. Therefore, every sequence of s+C is automatically excluded from the set of branching onsets. Instead, the spirant is projected rather as a rhyml complement to an empty nucleus or as a separate single onset. Bearing this in mind and considering the Binariness Theorem, one must conclude that three-consonant clusters cannot be branching onsets; nor can the two-consonant sequences starting with the /s/. In such cases the spirant is assigned to a single onset separated by an empty nucleus. It then acts as a governee in an Interonset Government.

In the preceding sections we have already excluded some consonant clusters where the second member is the sonorant /l/ on the basis of their word-internal behaviour: /pl/, /tʃ/, /tl/. Word-internally one can also find the /l/ following the /k^h/, /k/ and /f/ (cf. KRISTOFFERSEN 2000: 50): *takle* [taklə] (to tackle), *bagler* [pakler] (member of the Bishop's party in the Norwegian civil wars), *gafle* [kaflə] (to fork). This means that in the word-initial position they should be rather assigned to separated onsets with an intervening empty nucleus, instead of being projected as one branching structure. Obviously, no consonant cluster with the lateral /l/ as a second member can create a branching onset in Norwegian.

A rather marginal position among word-initial clusters have clusters consisting of /k^h/, /k/, /f/, /s/ followed by /n/, represented by relatively few forms in the modern language: *knall* [kɲal] (crack), *gnistre* [knistrə] (sparkle), *fnis* [ˈfni:s] (giggle), *snakke* [ˈsnak^h:ə] (speak). The last example is excluded outright from possible onsets because, as was said, the sonorant /s/ can never create a branching structure. The three remaining consonant sequences seem not to meet the criteria for a branching onset because the nasal is too complex to act as a governee in a branching onset (cf. GUSSMANN 2003: 332 for a similar conclusion for Icelandic and CYRAN 2003a: 311f for Polish). This leads to a straightforward conclusion that since /kɲ/, /kn/, /fn/ cannot form a branching onset, the consonants have to be projected as two simplex onsets with an intervening empty nucleus.

A very limited number of words in Norwegian start with the combination of two sonorants: /mj/ and /nj/. As observed in KRISTOFFERSEN (2000: 52), the sequence /nj/ only occurs in a few proper names, while the sequence /mj/ is more common. The evidence from Norwegian says little about these clusters (note that they are absent from the word-internal position, cf. KRISTOFFERSEN 2000: 60), but the data gathered independently from other languages show that the /j/ cannot be a dependent in a branching onset (cf. GUSSMANN 2003: 324, PLOCH 1999: 216). Since melodically the sonorant glide /j/ is a simplex expression made up of the element **I** only, we can formulate a constraint for this element (following GUSSMANN 2003: 324):

(6) The element I constraint:

Non-nuclear **I** must be alone in the onset

If we follow constraint (6) on the syllabic affiliation of the sonorant glide /j/, not only should the two word-initial sequences of two sonorants in question be excluded from well-formed branching onsets, but also sequences of /j/ preceded by /p^h/, /p/, /t^h/ and /t/, which, too, occur in Norwegian. Once again, we suggest the syllabification of the consonants as two consecutive onsets instead.

The last set of word-initial consonant sequences is composed of the three clusters /t^hv/, /tv/ and /k^hv/, with the approximant /v/ as a second member: *tvile* [t^hvi:lə] (doubt), *dverg* [tværk] (dwarf), *kval* [k^hva:l] (torment). From the point of view of the segmental complexity the clusters in question qualify as well-formed branching onsets. Since they are absent word-internally we cannot make radical claims for or against their onsethoodness. Still, because they behave as well-formed branching onsets word-initially, we suggest that the clusters in question should be classified as such, at least as long as no counter-evidence is found. As we will see, the same reservation has to be made for the obstruent plus [v] clusters in Icelandic (see below).

4.4. Possible and impossible branching onsets in Icelandic

Similarly to what we find in Norwegian, vowel length in Icelandic is not considered to be contrastive; hence, long vowels are to be found only in very restricted syllabic contexts, i.e. in stressed open syllables. Whenever a stressed rhyme is closed by a consonant, which is then governed by the following onset consonant, the vowel occupying the nucleus position is always short. In other words, a vowel which is followed by a cluster of two (or three) consonants, including geminates, can never branch. Consider the following examples:

- (7) senda [sɛnta] (send)
velja [vɛlja] (choose)
kassi [kʰas:i] (box)
fórn [fourŋ] (sacrifice)

However, as in Norwegian, the situation concerning the length of the stressed vowel is not as straightforward as it might appear on the first glance. As can be found in both handbooks on Icelandic (STEFÁN EINARSSON 1949: 4f) and phonological and phonetic case studies of the language (e.g. BALDUR RAGNARSSON 1978: 49, MAGNÚS PÉTURSSON 1976: 46f, 1978: 46f, INDRÍÐI GÍSLASON and HÖSKULDUR ÞRÁINSSON 1993: 44f), there is a set of consonant clusters which always follow a long vowel, consisting of one of the aspirated plosives or [s] ([s, p^h, t^h, k^h]) and [v, j, r]. This situation is illustrated by the following data:

- (8) Esja [ɛ:sja] (name of a mountain)
vepja [vɛ:p^hja] (lapwing)
hetja [hɛ:t^hja] (hero)
letra [lɛ:t^hra] (write)
vökvi [vœ:k^hvɪ] (fluid)
tepra [t^hɛ:p^hra] (prude)
titra [t^hr:t^hra] (shiver)
Ísrael [i:sraɛl] (Israel)

A short comment needs to be supplied to the combination of [k] plus [j], which has been excluded from the examples above. In fact, [k] followed by [j] does not produce the cluster [k^hj], as could be expected, but rather the single palatalised plosive [c^h], e.g. reykJa [rei:c^ha] (to smoke) (see GUSSMANN 2002: 159). In this respect a long vowel in this context is not surprising, since it behaves exactly in the same way as it would before any other single consonant, which is always projected as an onset.

Interestingly, some of the clusters are found not only word-internally, but also word-finally, which is not attested in Norwegian. Consider the following examples (GUSSMANN 2003: 325, MAGNÚS PÉTURSSON 1978: 48); we leave aside the purely technical difference between GUSSMANN's and MAGNÚS PÉTURSSON's approaches, (the latter assumes the forms in (9) to be exceptional, since no closed syllable can contain a long vowel (MAGNÚS PÉTURSSON 1976: 47)):

- (9) sötr [sœ:t^hr̥] (slurping)
pukr [p^hʏ:k^hr̥] (secretiveness)
snupr [sn̥ʏ:p^hr̥] (scolding)

In syllabic terms it means that in Icelandic potential branching onsets can be found not only word-initially, but also word-internally and word-finally. This implies further that word-final empty nuclei in Icelandic have a greater licensing potential than the ones in Norwegian, since word-final branching onsets are allowed only in the former language.

However, it is still worth analyzing which of the clusters that can be found in these syllabic positions above are genuine Icelandic branching onsets, and which of them only appear as such. Contrary to Norwegian (at least in its standard, non-dialect version), Icelandic data offer quite a rich device for such an analysis. The onsethood of particular consonant sequences can serve to testify against such individual, language-specific phonological phenomena as vowel length, preaspiration and stopness sharing.

4.5. Icelandic non-onsets

At the beginning of the analysis some sequences have to be excluded out of hand from the possible set of branching onsets in Icelandic. As it was mentioned above one set of

the clusters that follow a long vowel consists of [s] as the first member and [r, j, v] as the second member. Below some more examples are given:

(10) *flysja* [flr:sja] (peel)

hösvir [hœ:svɪr̥] (wulf)

lausra [lœi:sra] (loose, gen. pl.)

Although the sequences [sj] and [sv] occur word-initially (interestingly, the combination [sr̥] is totally absent in this position), we have to mention again what was said above about s+C sequences in Norwegian. One of the general claims made by Government Phonology is that the spirant can never be the governor in a branching onset. If it is followed by an obstruent and a stop sonorant ([n], [l], [m]), it is projected as the coda (with the preceding vowel appearing as short) whereas if followed by a continuant sonorant it syllabifies as a separate onset. Therefore, for the form *hösvir* we propose the following representation:

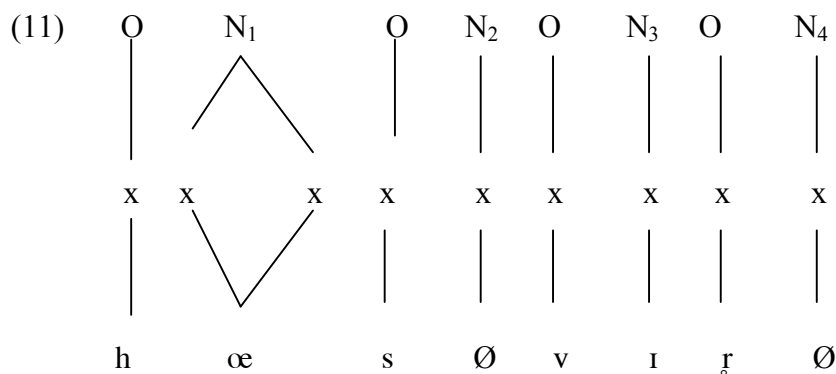

As one can see, our representation includes the empty nucleus N₂, which intervenes between the two consecutive onsets, of which the first one is occupied by the spirant [s] and the second by the continuant sonorant [v].

Since, as said above, such sequences (and additionally also [sj]) can be found in the word-initial position, we can extend our representation to word-initial positions as well. According to our analysis one will get the following representations word-initially, e.g.

(12) *Svavar* [sva:vaɾ] (proper name) s∅va:vaɾ∅

sjúkur [sju:k^hɪr̥] (sick, masc.) s∅ju:k^hɪr̥∅

Furthermore, we observed earlier that the sonorant glide [j] cannot act as a dependent in a branching onset structure; in other words, it has to be attached to a separate onset. This leads us to the exclusion of all C+j sequences from the set of possible branching onsets. If the sonorant is projected as an onset, the same has to be applied to the preceding obstruent, which, as we remember, can be either [p^h] or [t^h] (for the above-mentioned reasons [k^h] have been excluded), as in the additional data below:

(13) *nepja* [nɛ:p^hja] (bitter cold)

flytja [flɪ:t^hja] (to move)

lepja [lɛ:p^hja] (to lap)

setja [sɛ:t^hja] (to put)

In all these forms the obstruent and the following sonorant do not form a branching onset, but rather a sequence of two single, non-branching onsets broken up by an empty nucleus. Here is the possible representation of the form *nepja*:

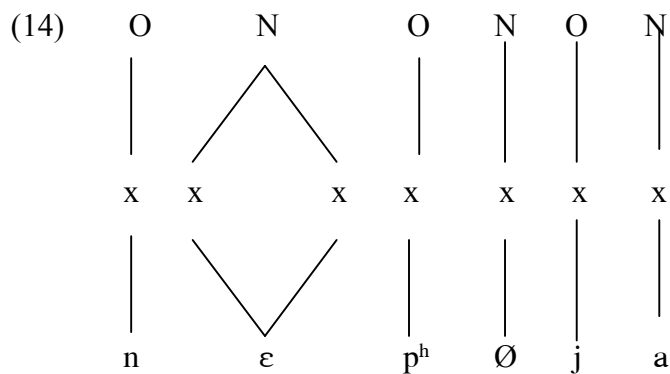

Consequently, if word-initially such sequences behave in a similar way, a word like *pjakkur* [p^hjahk^hʏr̥] (pointed stick) can be represented as follows:

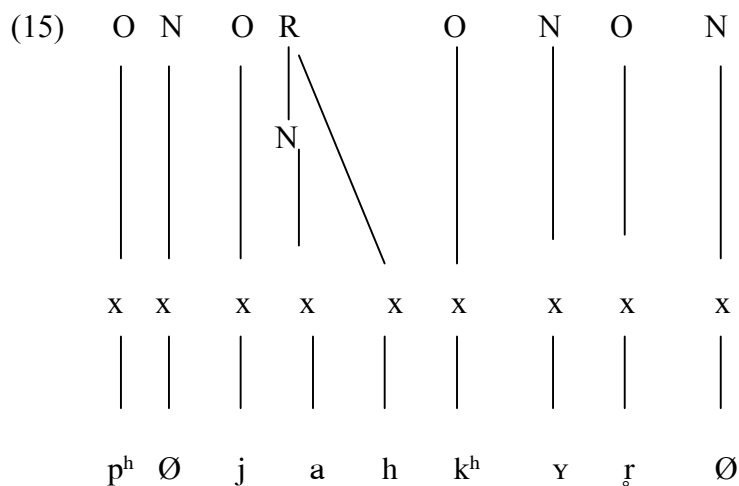

To sum up, all sequences occurring in the context of a long vowel, in which the first member is the spirant [s], must be excluded from the set of possible branching onsets in Icelandic. Instead, there occurs a structure where both [s] and the consonant (i.e. [r], [j] or [v]) belong to separate onsets. Such a constituent structure allows the preceding vowel to be long, since there is no coda to close the stressed syllable. Additionally, we tried to show that, similarly to Norwegian, the sonorant glide [j] cannot be a governee in a branching onset for any head governor (see the element **I** constraint in (6)). Instead, it has to be syllabified in the onset alone, as a result reducing the number of possible branching onsets in Modern Icelandic.

4.6. Branching onsets vs. preaspiration

Preaspiration in Icelandic is one the most well-described features of the phonology of the language. A number of the most important contributions devoted to this issue along with the very nature of preaspiration will be discussed in the following chapter.

Without going into details irrelevant in view of our present discussion, we only mention that preaspiration can be identified with the glottal spirant [h], which occurs in certain contexts. Roughly speaking, preaspiration occurs whenever a historically voiceless (i.e. tone-bearing) plosive appears graphically as a geminate (i.e. spelt <pp>, <tt>, <kk>). The result is not a geminated, but a singleton non-aspirated plosive preceded by the glottal spirant [h], as in the examples below:

- (16) kappi [k^hahpɪ] (hero)
hattur [hahtʏr] (hat)
þakka [θahka] (thank)

Interestingly, the vowel which precedes the glottal spirant [[h] in the preaspiration environment is invariably short, clearly demonstrating what the syllabic affiliation of [h] is, namely that it occupies the position of the rhyml complement.

Another context in which preaspiration occurs and which is directly connected with the discussion on branching onsets is the one where the aspirated plosives [p^h, t^h, k^h] are followed by any of the non-continuant sonorant [l, m, n]. In any case, such a sequence is preceded by preaspiration, like in the following examples:

- (17) epli [ɛhpɪɪ] (apple)
lapm [lahpm̩] (buddy)
opna [ɔhp̩na] (to open)
ætla [aihtla] (to intend)
batna [paht̩na] (to improve)
rytmi [rɪht̩mɪ] (rhythm)
hekla [hɛhk̩la] (to crochet)
drakma [trahkm̩a] (drachma)
vakna [vahk̩na] (to awaken)

Noteworthy, most of the consonant combinations that are found in the word-internal position in the examples above (17) can also occur word-initially, apart from the homorganic sequences /tl/ and /tn/, which are completely absent in this position in Modern Icelandic (as it seems, the non-occurrence of these consonant combinations can be seen as a universal gap in the constituent structure (see KAYE et al. 1990: 212)). Here are some examples:

- (18) plan [p^hla:ŋ] (open space)
knár [k^h̩nau:r] (energetic)
klífa [k^h̩li:va] (to climb up)

None of the above consonant combinations, however, qualifies as a well-formed branching onset. Since the nasals are too complex to act as governees of an onset head (note the absence of the sequences /k^hm/ or /p^hn/ and /p^hm/ word-initially, which certainly is not accidental), and since sequences of homoorganic obstruents and sonorants are universally excluded, only the combination of an obstruent and a following lateral could potentially be analysed as a branching onset. This, however, is not the case, as the data in (17) reveal. If any of the sequences belonged to the set of branching onsets in Icelandic, one could expect a long vowel to precede. Such forms with long vowels, however, do not exist, which undoubtedly indicates that preaspiration occurs exclusively before sequences that are not potential branching onsets in Icelandic. Instead, in any case, the two consonants in question belong to separate onsets rather, with an intervening empty nucleus in between. Consider the possible representation of the form *vopn*, taken from GUSSMANN (2003: 333):

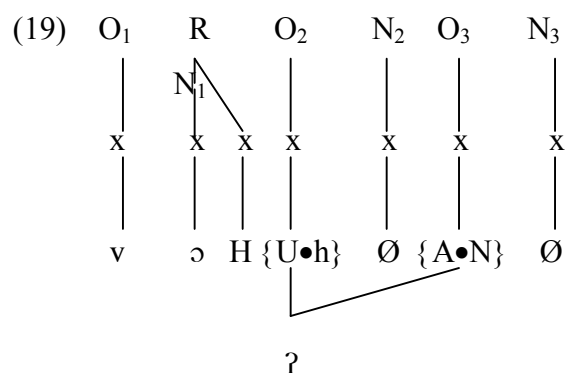

The representation above helps us explain the nature of preaspiration. The stopness element is attached to two onsets (O₂ and O₃, separated by the empty nuclear position N₂); the first contains the high tone element **H** which is dislodged onto the position of the rhymal complement. The dislodgement of the high tone element **H** is a result of the de-aspiration of the plosive, which we mentioned above. This follows from a more general feature of Icelandic according to which the two elements **?** and **H** tend not to be combined within a single expression (see GUSSMANN 1999: 172). This issue will be more thoroughly discussed in a separate section on preaspiration and the dialectal difference between the so-called *linmæli* and *harðmæli*.

4.7. Impossible onsets and stopness sharing

The preceding section showed the contexts in which preaspiration occurs and described the relevant set of consonant clusters that are preaspirated. As we demonstrated, none of the preaspirated consonant sequences qualifies as a potential well-formed branching onset in Modern Icelandic. The data of this language includes a number of words containing phonetically identical clusters although never preceded by the glottal spirant [h], i.e. those uninvolvement in the preaspiration context. This is showed in the following examples (the sequences in question are boldfaced):

- (20) a. treflar [t^hre**pl**ar] (scarf, Pl.) ⇐ trefill [t^hre:vɪtl] (Nom. Sing.)
sagna [sa**kn**a] (story, Gen. Pl.) ⇐ saga [sa:ɣa] (Nom. Sing.)
þöglar [θœ**kl**ar] (silent, Nom. Pl. Fem.) ⇐ þögull [θœ:ɣʏtl] (Nom. Sing. Masc.)
- b. biblía [pi**pl**ia] (Bible)
efni [e**pn**i] (material)
safn [sa**pn**] (collection)

A common property of all the forms above is that stressed vowel is short, which shows that the first consonant of the clusters in question (a toneless plosive) has to be assigned to the position of the rhymal complement and, then, closes the syllable. Structurally there occurs the following governing relation: the stop sonorant in the onset acts as the head of a toneless stop governee in the coda (right to left government), which seems to question the prediction of the theory we try to apply. According to our analysis in the preceding section, it would be natural to expect preaspiration, which, however, does not occur in any of the forms in (20). Obviously, although phonetically identical, the consonant sequences in (20) have to be phonologically distinct from the ones which occur in the preaspiration context. This distinction seems to be perfectly justified once the melodic make-up of the discussed consonant combinations is considered. Following GUSSMANN (2000: 97), we decide to call the consonant sequences in (20) *secondary clusters*, since their origin is quite different from the ones that occur in the context of preaspiration. In a secondary cluster, the first member was originally not a plosive (GUSSMANN 2000: 97). We saw above that it is the hightone element **H** that is responsible for the presence of preaspiration before a specific set of consonant combinations. Since no preaspiration occurs before the secondary clusters in (19), we conclude that the stop consonants assigned to the rhymal complement are toneless, i.e.

there is no high tone element **H** in their melodic make-up which could serve as a source of preaspiration. The “stop nature” of the coda consonants follows from the transition of the stopness (occlusion) element **ʔ**, contained in the stop sonorant that occupies the onset, to the rhymal spirant.

Noteworthy, the evidence that the toneless plosives in the rhymal complement go back historically to consonants other than plosives is reflected in two ways. On the one hand, it is the spelling that indicates the historical origin of the consonants (examples (20b)). Here perhaps only the form *biblía* [pɪplia] can be somewhat misleading, although according to the *Íslensk orðabók* (2003) another spelling of the word is possible, namely *bíflía*, with the same pronunciation as *biblía*, hence conforming to other forms in (20b.). It is a matter of course that spelling cannot serve as a source of evidence for phonological analyses; it can only give us some information about historically conditioned changes in a language. For an interesting discussion on Icelandic spelling see GUSSMANN (2007).

The fricative-origin of the coda stops can clearly be seen in the examples (20a.). Obviously, forms like *treflar* [tʰreplar̥], *sagna* [sakna] or *þöglar* [θœklar] are morphologically related with forms containing a fricative, e.g. *trefill* [tʰre:vɪtl], *saga* [sa:ɣa], *þögull* [θœ:ɣʏtl]. Examples like these are numerous; below we present some more data:

(21) *dúfa* [tu:va] (dove) vs. *dúfna* [tupna]

hagur [ha:ɣɣ̥r̥] (circumstances) vs. *hagnaður* [haknaðɣ̥r̥] (profit)

stífur [sti:vɣ̥r̥] (stiff) vs. *stífni* [stipni] (stubbornness)

deigur [tei:ɣɣ̥r̥] (damp) vs. *deigla* [teikla] (melting pot)

stafur [sta:vɣ̥r̥] (stick) vs. *hásteflingur* [hau:stɛplɪŋkɣ̥r̥]

Thus, whenever morphophonemic processes bring the fricative and a stop sonorant together, the former consonant is turned into a toneless plosive due to the transmission of the occlusion element from the following stop sonorant (GUSSMANN 2003: 335). Concluding, in Modern Icelandic every sequence of a toneless spirant followed by a stop sonorant is ascribed the structure of a coda-onset governing relation, whereas the fricative is turned into an unaspirated plosive immediately assigned to the position of the rhymal complement. Since the vowel which precedes such governing relation is always short, the sequences in question must be rejected from the set of possible branching onsets in Icelandic.

For language-internal reasons every word-medial sequence of a toneless spirant and a stop sonorant is totally excluded and automatically conversed to a toneless plosive acting as a governee for an onset head in form of a non-continuant sonorant (i.e. coda-onset contact). Hence, word-internal combinations like [fl] and [fn] are not admissible. Word-initially, however, such sequences do occur, as demonstrated by forms like *fleka* [flɛ:kʰa] (to seduce), *flóa* [flou:a] (to boil), *fnæsa* [fnai:sa] (to spit), *fnykur* [fnɪ:kʰʏr] (bad smell). It has to be noticed here that although examples with word-initial [fl] are numerous, the number of forms with [fn] is very limited (the *Íslensk orðabók* lists only 13 entries with initial [fn]). At least the combination [fl] could potentially be ascribed the status of a branching onset, if, however, there were no evidence that the cluster is not admitted word-internally. Due to the undisputable fact that the gap exists and that it invariably affects all forms with internal postvocalic [fl] (and in a similar fashion those with [fn] as well), it has to be concluded that neither [fl] nor [fn] belong to the inventory of Icelandic branching onsets.

4.8. True branching onsets in Icelandic

After rejecting a considerable number of both word-initial and word-internal consonant sequences in Icelandic, which from the traditional point of view would be included into the set of well-formed branching onsets, we are left with very limited and restricted combinations. In fact, only the aspirated plosives followed by [r] (and, although not very numerous, by [v]) meet the requirements of our theoretical assumptions. Consider some more examples below (see additionally (12) above):

- (22) *glopra* [klo:pʰra] (to lose)
skrökva [skrœ:kʰva] (to tell a lie)
glitra [kl:tʰra] (to glitter)
uppgötva [ʏhpko:tʰva] (to discover)
nötra [no:tʰra] (shake, tremble)

That this rule for vowel length before an obstruent plus [r] or [v] is a live phonological process in Modern Icelandic can be testified against word forms that clearly do not belong to the native Icelandic vocabulary. Although not very numerous, such examples

prove that our previous predictions were right. Consider the following examples from GUSSMANN (2003: 327f):

(23) hebreskur [hɛ:prɛskʏr] (Hebrew)

edru [ɛtru] (sober)

Afríka [a:frikʰa] (Africa)

febrúar [fɛ:pruɑr] (February)

Ekvador [ɛ:kʰvatɔr] (Ecuador)

In the preceding sections we have examined some Norwegian and Icelandic consonant sequences in word-internal and word-initial position. The aim has been to establish a comprehensive set of branching onsets in both Norwegian and Icelandic and compare these governing domains in the two languages. Starting with word-internal consonant sequences which cause the lengthening of the stressed vowel we showed that only some of them qualify as branching onsets (in fact, only the plosives and /f/, i.e. obstruents followed by /r/). The next step was to supply our analysis with word-initial consonant clusters. We saw that among the considerable number of clusters allowed in the word-initial position in Norwegian and Icelandic only the above given sequences and additionally the three consonant combinations /tv/, /dv/ and /kv/ meet the criteria for branching onsets. Hence, the set of well-formed branching onsets in Modern Norwegian and Modern Icelandic seems to consist of the plosives and the voiceless fricative /f/ followed by /r/ or /v/.

4.9. A side-glance to Faroese

Additional evidence for our analysis of true branching onsets can be found in Faroese, which is the closest relative of Icelandic. As in Icelandic, Faroese vowels and diphthongs can be short and long.⁸ In brief, a general rule of vowel quantity in Faroese is precisely the same as in Icelandic and Norwegian: stressed vowels or diphthongs are long if no more than one consonant follows, otherwise they are short. However, before certain consonant clusters one

⁸ However, unlike in Icelandic and Norwegian, there is a considerable difference in quality between the long and short variants. In many cases a short monophthong corresponds to a long diphthong. We leave this issue aside as irrelevant for our discussion. For further details the reader is referred to the handbook by HÖSKULDUR ÞRÁINSSON, HJALMAR P. PETERSEN, JÓGVAN Í LON JACOBSEN AND ZAKARIS SVABO HANSEN (2004).

finds long nuclei, (see HÖSKULDUR ÞRÁINSSON, HJALMAR P. PETERSEN, JÓGVAN Í LON JACOBSEN AND ZAKARIS SVABO HANSEN 2004: 30f.):

- (24) *daprir* [t̪ea:pʰrɪr] (sad)
 epli [e:pʰlɪ] (apple)
 bekla [pe:cʰla] (walk crookedly)
 akvamarin [ɛa:cʰvamarɪn] (beryl)
 akrar [ɛa:cʰrar] (fields)
 Petra [pʰe:tra] (name)

The whole set of the lengthening clusters are as follows:

- (25) [pʰr], [pʰl], ([pʰj])⁹, [cʰr], [pl], [tr]

In addition, one finds also orthographic consonant combinations (tj, kj, sj) which are however pronounced as a single consonant ([tʰj], [tʃ] and [ʃ] respectively) and conform as such to the general quantity rule.

Interestingly, just as one could expect, no short vowel appears when the cluster [tʰl] follows. Before [tʰl] we get a short vowel and a preaspirated [t], e.g. *stetla* [st̪ɛʰtla] (hobble, limp). It only confirms our assumption that the sequence [tʰl] is not a possible branching onset universally.

⁹ The sequence [pʰj] does not exist word-internally, but it could be classified as a potential well-formed branching onset, since it appears at the beginning of the word (e.g. *þjaka* [pʰjea:cʰa] (potter about)). However, bearing in mind what we said about the universal restrictions on the syllabic affiliation of the non-nuclear **I** (cf. 6 above), the sequence [pʰj] has to be treated as two separate onsets.

Chapter 5. Preaspiration in Icelandic – more about melody and syllabic structure

The relationship between vowel length and preaspiration seems to be straightforward and simple, as we presented in the previous chapter: preaspiration can only follow a short vowel. Long vowels are totally excluded from the context of preaspiration, since the preaspiration segment, i.e. the glottal spirant [h] necessarily occupies the position of the rhymal complement. At this point one could close the discussion; however, as preaspiration involves a number of interesting additional issues (such as the main dialectal differences of the otherwise rather uniform language), it might seem appropriate to extend the presentation with a glance at this feature of the language.

Icelandic preaspiration is perhaps the feature of Icelandic phonology that have attracted the greatest attention in the scholarly literature. A sizeable number of studies has been devoted to the phonetics and phonology of preaspiration, caught in different and often competing theoretical frameworks. LIBERMAN (1982: 90ff) offers a survey of earlier works on the subject. Within the generative, non-linear tradition the articles by HÖSKULDUR THRÁINSSON (1978), KRISTJÁN ÁRNASON (1986) and HERMANS (1985) need to be mentioned. Other works that deal with the problem are BOTMA (2001), MORÉN and MIGLIO (2000), RINGEN (1999) (developing the ideas of Optimality Theory) and JÓHANNES G. JÓNSSON (1994), who works with the licensing conditions on the feature [asp], as well as the recent paper by LODGE (2007), caught from a somewhat odd point of view. PÉTUR HELGASON (2002) puts preaspiration in a broader, both diachronic and typological context. The paper by WERESZCZYNSKI (2005) goes back to idea that preaspiration is in fact a voiceless vowel. The following discussion will be based on the analyses that have been put forward by GUSSMANN (1999) and (2000). It should be also stressed that preaspiration is a feature that can be also found in Norwegian, however not in the standard language, but rather in some of its dialects (Southwest Norwegian, Hallingadal, Northern Gudbrandsdal and Southern Trøndelag, see CHAPMAN (1962: 61)). As a non-standard, archaic dialectal feature, preaspiration in Norwegian will not concern us here.

The previous discussions on preaspiration in Icelandic have concentrated mostly on the segmental status of this feature and its relation to aspiration, which, cross-linguistically, is a more common feature. Some of the older phoneticians (e.g. STEFÁN EINARSSON 1927, BJÖRN GUÐFINSSON 1946) assumed that preaspiration is an inverse of aspiration (we use

the term ‘inverse’ after GUSSMANN 2000: 93); hence, in their works both preaspiration and aspiration are marked as the raised [h] in front or after the plosive respectively:

(1) *koppur* [k^hɔ^hpʏr̥] (chamber pot)

hattur [ha^htʏr̥] (hat)

Others, starting with JÓN ÓFEIGSSON (1920-1924), identified preaspiration with a full segment and transcribed it as the glottal spirant [h]. This tradition has been established especially due to the phonological and phonetic works by MAGNÚS PÉTURSSON, whose acoustic measurements showed that preaspiration has a longer duration than aspiration and that the consonant following preaspiration is short. Additionally, he made reference to the movements of the soft palate, which, according to his measurements, were exactly the same as when producing the glottal stop [h] (see KRISTJÁN ÁRNASON 2005: 205f for a review of the past tradition). In the following pages we treat preaspiration as a full segment.¹⁰

We showed in the preceding chapter that preaspiration and the contexts in which it occurs, are directly connected to the vowel quantity regularities that can be established for the phonological system of Icelandic. Let us repeat some of the main facts about preaspiration and present some illustrating data.

As already said, preaspiration occurs in two main contexts. One of them takes place when in orthography there occur *pp*, *tt* or *kk*. Let us consider some exemplifying data:

(2) *kappi* [k^hahpɪ] (hero)

hoppa [hɔhpa] (hop)

köttur [k^hœhtʏr̥] (cat)

þakka [θahka] (thank)

sokkur [sɔhkyr̥] (sock)

Historically, we deal here with the voiceless geminated stop consonants, which, as we remember from our previous discussion, are always voiceless and differ from their historically

¹⁰ Again, a look at the Faroese data can be quite instructive. As it seems, the phonological nature of preaspiration varies from one language to another. In Icelandic preaspiration functions as a segment, whereas in Faroese, as numerous phonetic studies showed, preaspiration is much shorter than the closure period of the following stop (cf. HÖSKULDUR ÞRÁINSSON, HJALMAR P. PETERSEN, JÓGVAN Í LON JACOBSEN AND ZAKARIS SVABO HANSEN 2004: 47). This is reflected in the phonetic transcription of Faroese, e.g. [h^hp], [h^ht], [h^hk].

voiced counterparts only in that the former appear as aspirated, while the latter as non-aspirated. By the way, the examples above clearly show that Icelandic does not permit geminated tone-bearing plosives, which are realized as a sequence of the preaspiration segment [h] and a non-aspirated single plosive instead ([hp], [ht], [hk]). On the other hand, examples of geminated non-aspirated, i.e. historically voiced plosives are numerous:

(3) labba [lap:a] (walk slowly)

gaddur [kat:ʏr] (spike)

hugga [hyk:a] (comfort)

We will soon come back to the difference between the two sets of consonants. But first let us recognise the second context in which preaspiration occurs, namely that preaspiration appears whenever one of the historically voiceless plosives (i.e. [p^h], [t^h], [k^h]) is followed by any of the stop sonorants (i.e. [l], [m], [n]). Consider the following data (recall also (17) in the preceding chapter):

(4) vopn [vɔhpɲ] (weapon)

rakna [rahkna] (unravel)

lyklar [lɪhklaɾ] (key, Nom. Pl.)

katli [k^hahtlɪ] (kettle, Dat. Sg.)

ekla [ɛhkla] (scarcity)

vetni [vɛhtɲɪ] (hydrogen)

The fact that Icelanders tend to preaspirate even in foreign words, e.g. when speaking English, shows that preaspiration is an active rule in Modern Icelandic (I use examples from HÖSKULDUR THRÁINSSON 1978: 19 with just a slightly modified transcription):

(5) poplar [p^hɔhplaɾ]

butler [pœhtlɛɾ]

utmost [œhtmost]

Both the data in (2) and (4) show one common context in which preaspiration occurs, namely that there are always the historically voiceless stops that are involved in the preaspiration rule. Additionally, in (4) we also find Icelandic sonorants, but in point of fact only the stop ones. As the data reveal, the sonorant [r] is excluded from this context. Whenever one finds the sonorant [r] following a plosive, no preaspiration occurs. Instead, every sequence of this kind is invariably preceded by a long vowel, a regularity which we described in the chapter devoted to open syllables and branching onsets in Icelandic and Norwegian.

In the following section an attempt will be made to explain why precisely these very consonants are involved in the preaspiration complex, as described above, in other words, what makes the stops special with regard to preaspiration.

5.1. Melodic interpretation of preaspiration

We stressed at several places before that in Modern Icelandic (in fact, also in Modern Norwegian) the main difference between the set of consonants spelled as *p, t, k* on one hand and *b, d, g* on the other is not the absence and presence of voicing respectively, but rather one of aspiration. In other words, from synchronic point of view, the historically voiced stops are just non-aspirated counterparts of the historically voiceless stops. In Government Phonology, which argues that phonological expressions are made of melodic elements in their different combinations (recall our initial discussion on the theoretical premises of the framework), it is generally assumed that the elements that are responsible for the laryngeal activities are the source elements **H** (the high tone element) and **L** (the low tone element). In the Germanic languages, unlike e.g. the Romance or Slavic languages, it is the high tone element that is exploited in the regularities concerning voicelessness and aspiration (see e.g. Harris 1994: 133ff.); hence voicing, if present at all, is interpreted as the absence of the high tone element in the melodic make up of a segment. In this sense Icelandic plosives seem to offer an ideal fit

for this scheme, since they are never voiced and tend to be distinguished by the presence of aspiration only (GUSSMANN 1999: 168, GUSSMANN 2000: 96f.). Following this reasoning, it becomes quite clear why it is precisely the historically voiceless plosives that are involved in the complex of preaspiration. In other words, preaspiration is a tonal phenomenon traceable to the presence of the high tone element on the plosive consonants (GUSSMANN 1999: 168). Moreover, the plosives consonants combine the high tone element **H** with the occlusion (stopness) element **ʔ**. To demonstrate that this combination plays a crucial role in the phonology of the language, we will have a brief look at one of the few dialectal features of Icelandic, namely the difference between the so-called *harðmæli* ('hard speech') and *flámæli* ('soft speech').

In all forms of Icelandic aspirated plosives appear domain-initially, as the following data illustrate:

(6) tala [t^ha:la] (speak)

penni [p^hɛnɪ] (pen)

koma [k^hɔ:ma] (come)

Domain-initial position has a prominent place in the syllable structure, since it is licensed by a strong licensor, namely the stressed vowel which constitutes the head of the licensing domain. In Government Phonology it is generally assumed that the licensing abilities of nuclei may vary, depending on the position in which the licensor occurs (for the idea of licensing strength of nuclei with reference to data from different languages see especially CYRAN 2003b). Hence, one can also assume that licensors in weak syllabic positions (i.e. positions removed from the head of the domain) may have less licensing abilities. This is in fact what occurs in the above-mentioned *harðmæli* and *flámæli*. Here are some examples of this difference:

(7) a. *harðmæli*

tapa [t^ha:p^ha] (loose)

taka [t^ha:k^ha] (take)

láta [lau:t^ha] (put)

b. *flámæli*

tapa [t^ha:pa] (loose)

taka [t^ha:ka] (take)

láta [lau:ta] (put)

As the data reveal, the difference between the two forms of Icelandic lies in the pronunciation of the word-medial plosive. In *harðmæli* the medial plosives appear as aspirated, while in *flámæli* they lack aspiration. As to the latter, the conclusion is that a non-stressed vowel, (a weak licenser) has not enough licensing strength to license the combination of **ʔ** and **H**. As a result, the high tone element is deleted and phonetically inaudible (GUSSMANN 1999: 170).

Preaspiration can also serve as an explanatory device for another dialectal feature of Icelandic, namely the so-called devoicing of sonorants (see HÖSKULDUR THRÁINSSON 1980 for an extensive discussion within a non-linear theoretical framework). The feature itself varies from dialect to dialect, though one can conclude that the sonorants [r, l, m, n] are devoiced in front of a hard plosive in the southern and south-western part of the country, while in the North of Iceland “everybody has voiceless [r̥] before /p, t, k/ and some instances at least of voiceless [l̥] before /t/, but only some speakers have voiceless [l̥] before /p, k/ and voiceless [m̥, n̥] before /p, t, k/” (HÖSKULDUR THRÁINSSON 1980: 355). Crucially, when the sonorant is devoiced, the following plosive appears as non-aspirated and as aspirated when no sonorant devoicing takes place. Consider the following data:

(8) a. sonorant devoicing (southern dialects)

stulka [stul̥ka] (girl)

gelta [ʒ̥ɛl̥ta] (bark)

banka [pau̯ŋka] (knock)

vanta [va̯nta] (lack)

kampur [k^hamp_̥pyr̥] (moustache)

aumka [øym_̥ka] (pity)

b. no sonorant devoicing (northern dialects)

stulka [stulk^ha] (girl)

gelta [ʒɛlt^ha] (bark)

banka [paun_̥k^ha] (knock)

vanta [vant^ha] (lack)

kampur [k^hamp^hyr̥] (moustache)

aumka [øymk^ha] (pi

The sonorant devoicing which takes place in the examples in (8a) can be easily explained: the onset plosive, which is the governee for the sonorant in the position of the rhymal complement, contains, as we argued above, the combination of the elements **ʔ** and **H**. As we saw, this combination is preferentially avoided in Icelandic; therefore, what occurs in (8a) is in fact a dislodgement of the hightone element from the plosive to the coda sonorant. Consequently, the sonorant phonetically is realized as voiceless, while the onset stop as non-aspirated. This does not happen in the northern dialects, where complications are numerous. The fact that in everyone's speech the sonorant [l] devoices, can be explained, according to Gussmann's argumentation (GUSSMANN 1999: 171f.), by the melodic make up of the consonant. On the assumption that [l] consists of the stopness and coronality elements only (**ʔ**, **A**), while e.g. [m] and [n] contain additionally the nasal element **N**, we conclude that nasal sonorants are melodically more complex than [l], and therefore more difficult to govern. The same can be said about [r], which, as we recall, devoices both in the southern and northern dialects of Icelandic.

The main two dialectal features of Icelandic, which we sketched above, have been used as an initial illustration for the melodic representation of preaspiration. We showed that it is the high tone element **H** that is responsible not only for the presence of aspiration in certain contexts, but also for a number of additional issues, such as sonorant devoicing or deaspiration of plosives in the medial position. Our discussion on dialectal differences in

Icelandic showed that the combination $\text{?}\cdot\text{H}$ (i.e. occlusion and high tone), as the basic melodic content of aspirated plosives, does not occur in a single phonological expression. This leads directly to the discussion on the syllabic status of preaspiration.

5.2. Syllabic status of preaspiration

As one recalls, preaspiration contexts involve hard geminates *pp*, *tt*, *kk* (realised as the spirant [h] and a single non-aspirated plosive) and hard plosives when followed by a stop sonorant [l, m, n]. As it was said in above, that preaspiration can only follow a short, non-branching nucleus. In Icelandic long nuclei preceding preaspiration are totally inadmissible. The natural conclusion, then, is that the preaspiration segment necessarily occupies the position of the rhymal complement. Below we present a possible syllabic representation of the form *köttur* [k^hœhtyr̥] (cat):

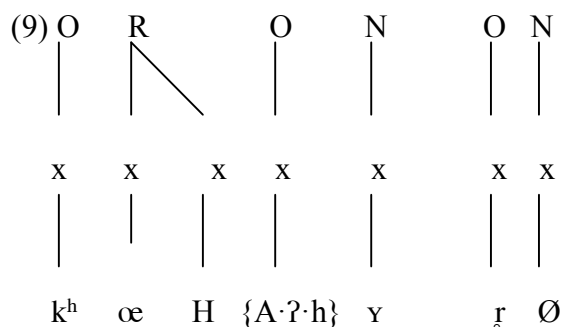

The above structure may be accounted for in the following way: if the combination of stopness and high tone cannot occur, then the high tone element is dislodged from the governor plosive in the onset and associates with the governee position of the coda. At the same time it explains why the plosive appears as non-aspirated. Since the element H cannot be doubly attached in a phonological expression, it has to be removed from the melodic composure of the onset and stay only within the coda position. The effect is perceived as preaspiration realised as the glottal spirant [h], while the plosive itself (hard, i.e. aspirated if in isolation) does not differ phonetically from its soft counterpart, which is reflected in the transcription. In this sense, preaspiration demonstrates one of the possible mechanisms that are used by the phonological system of the language to solve the incompatibility between the

stopness element **ʔ** and the high tone element **H** within a single phonological expression that is not licensed by the head of the domain.

The second context of preaspiration (that is the plosive-stop sonorant cluster context) requires an additional explanation. On the basis of the above data we see that also in this context the plosives appear as non-aspirated. Plosives, if containing the high tone element in their melodic composure, can either be pre- or postaspirated, but never both (GUSSMANN 1999: 175). Additionally, both the plosives and the sonorant involved in preaspiration, contain the stopness element **ʔ**, a fact which would run against the so-called Obligatory Contour Principle. Furthermore, there are additional arguments for assuming that the plosive and the following sonorant are not necessarily adjacent on the skeletal level. Obviously, the plosive cannot be associated with the position of the rhyml complement for two reasons: firstly, it would mean that the more complex plosive acts a governee for a less complex sonorant; secondly, the position of the coda is already occupied by the preaspiration segment. On the other hand, the sequence consisting of the plosive and the stop sonorant hardly qualifies as a possible branching onset, since stop sonorants are too complex to be governed in such a governing domain. We are, then, left with a structure where both the plosive and the stop sonorant are assigned to two separated onsets with an empty nucleus in between. Consider the following representation of the form *vopn* [vɔhpɲ] (weapon):

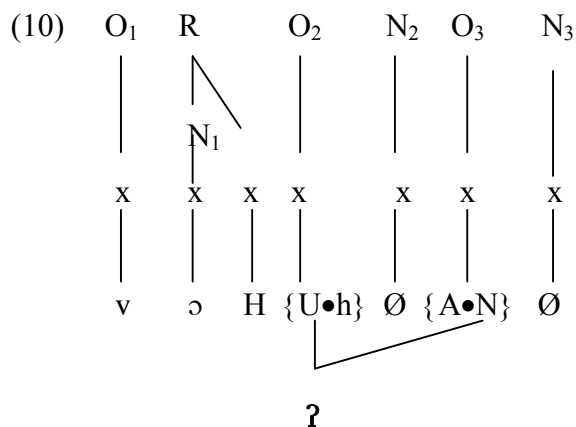

The structure has a number of theoretical implications. First of all, the stopness element is attached to two positions (O₂ and O₃) at the same time. Such a strong association excludes the possibility that the high tone element would be associated to the same position. Hence, the element H is dislodged from the position O₂ and “moves” to the coda, where it is perceived

as preaspiration. Again, the originally hard plosive in the onset O₂ is pronounced exactly as its soft counterpart. Since O₂ does not contain the high tone element **H** any longer, the following sonorant cannot undergo devoicing.

GUSSMANN (1999: 178f.) proposes the following regularity which combines the two different contexts of preaspiration (the geminate and pre-cluster context):

(11) **Dislodge H Principle**

Dislodge **H** onto the preceding rhymal complement if combined with doubly attached ?

In general, preaspiration is one of the many mechanisms that a given language has at its disposal to solve the problem of inadmissible or dispreferred structures or combinations of elements. The dislodgement of the high tone element from an expression which contains the stopness element can, therefore, be seen as a way of rectifying a structure which proves unacceptable in the language (GUSSMANN 1999: 179).

Finally, once again the connection between preaspiration and vowel length should be stressed. All the data that have been presented in the core of the discussion leave no doubt that preaspiration and long nuclei are, in a sense, in complementary distribution. A long vowel can never be followed by preaspiration and, conversely, preaspiration can never be preceded by a long nucleus. This remains in accordance with our general assumptions about vowel length in Icelandic. Long vowels can only appear in open syllables, i.e. where the rhymal complement is not occupied by a consonant. As we proved, in any such case the preaspiration segment [h] is automatically assigned to the coda. What is left for the nucleus is only a single skeletal slot within the rhyme; this is why the vowel must be short.

Chapter 6. Quantity and the Norwegian retroflex consonants

In the following section we shall take a look examine a specific feature in the phonology of Norwegian, namely the retroflex consonants, occurring in the dialects of Eastern and Northern Norway. While some topics in the phonology of the language have attracted little or no interest in the literature, the retroflex segments have been studied at length (see RINNAN 1969, ENDRESEN 1974, FRETHEIM 1974, RYKKVIN 1946, STEBLIN-KAMENSKIJ 1965). However, one can hardly find a satisfying phonological description of this phenomenon, nor has a unified definition been given of what is meant by a retroflex consonant. We will therefore try to analyse the retroflex consonants in phonological terms, paying particular attention to the position of the retroflex segments within the syllabic constituents. We will also present to what extent the processes taking place on the melodic level are independent of the processes affecting the skeletal tier.

6.1. What is a retroflex?

In the dialects of Eastern and Northern Norway (but also in central and Northern Swedish, and in Faroese (see HAGSTRÖM 1970), and in some languages from outside the Germanic group, (see KUSMENKO 2003)) the rhotics /r/ or /r̥/ plus a member of the unmarked coronal series, /t, d, s, l, n/ fuse into one apical segment, respectively /ṭ, ḍ, ṣ, ḷ, ṇ/. In fact, if there is another dental that follows a retroflex, it also turns into a retroflex consonant: barn [ba:r̄ŋ] (child) – barns [ba:r̄ŋs̄] (child, gen. sg.) (KUSMENKO 2003: 185). Phonetically the retroflex consonants has been described in many different ways: as *sublamino-postalveolar* (ENDRESEN 1988: 22), *alveolar* (VANVIK 1972: 137f.), *apicals* (KRISTOFFERSEN 2000: 22). A retroflex sound is articulated by the tip of the tongue with the back of the alveolar ridge, or even further back towards the highest part of the hard palate. In the latter case the tip of the tongue is frequently ‘inverted’, i.e. curled upwards towards the hard palate (POPPERWELL 1963:60). The phonetic description of the retroflex sounds will not concern us here. It is worth mentioning that even in the dialects where the retroflex consonants do occur, the combinations of /r/ plus a dental consonant may replace the retroflex sounds (KRISTOFFERSEN 2000: 89 speaks about a split pronunciation). Another important

fact, brought to my attention by Helge SANDØY (pc.), is that retroflex consonants occur not only in simplex words, but also across morphological and syntactic boundaries:

Hvor er du nå? [vur æ:dʁ no:]

According to SANDØY, this observation is crucial and should be included in every comprehensive analysis.

6.2. The syllabic status of retroflex consonants with respect to vowel quantity

In this section we will concentrate on the relationship between the position of a retroflex consonant on the skeletal level and length of the preceding vowel. As we said before, the vowel can only be long when no coda consonant is present (the so-called open syllable lengthening). Consider the following examples:

(1.) jern [jæ:ŋ] (iron)	ærlig [æ:i] (honest)	bords [bu:ʂ] (table, gen.sg.)
barn [ba:ŋ] (child)	Karl [ka:]	mors [mu:ʂ] (mother, gen.sg.)
tårn [tɔ:ŋ] (tower)	jarl [ja:] (earl)	Lars [la:ʂ] (male name, gen.sg.)
korn [kɔ:ŋ] (corn)		
ørn [ø:ŋ] (eagle)		

The long nucleus in all these forms suggests that the word-final retroflex consonant cannot belong to the same syllable. What can it be, then? If we follow the theory-internal claim that every word-final consonant is invariably heterosyllabic, i.e. an onset of the next syllable (see GUSSMANN and HARRIS 1998), the retroflex /ŋ/, /l/ and /ʂ/ would have to occupy the onset position, being licensed by the following empty nucleus. But there are more conditions a consonant must fulfil to become an onset. It should be able to occur word-initially. If it does not, there should be strong reasons for its absence in this syllabic position. In Norwegian there are no words starting with /ʂ/, /ŋ/, /l/, /t/ or /d/ (see AWEDYKOWA 1997: 115 f., KRISTOFFERSEN 2000: 49). As far as I know there has been no attempt to answer this

question in the phonological literature. In KRISTOFFERSEN (2000: 49) we can only find a simple statement that “(...) *it is difficult to say by means of loanwords whether the absence of the former set is due to an accidental gap or to a true constraint (...)*”. The answer, however, seems to be quite simple and lies in the fact that a retroflex consonant is in fact a result of a merger of the /r/ with the following dental. In Norwegian a cluster consisting of a /r + coronal/ is generally excluded from the word-initial position (as a matter of fact, the same holds for the clusters /n + velar/; hence, there are no words starting with the velar nasal /ŋ/).

Let us now analyse the possible representation of the structure for *barn*:

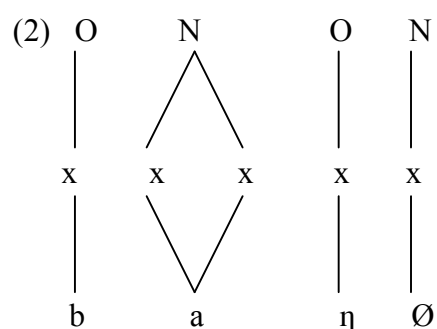

We will start the analysis of the retroflex consonants paradoxically with a few words about those dialects of Norwegian that lack this series of consonants, i.e. dialects, where the rhotic and the following dental are “split”, in KRISTOFFERSEN’s term.

In the above mentioned dialects the forms in (1) would all have a short vowel preceding the /r/, which hence has to occupy the coda position. From the theoretical point of view this is a very favourable situation, because we deal with a typical coda-onset juncture, where the nasal /n/ (containing three elements) governs the monoelemental tap /r/:

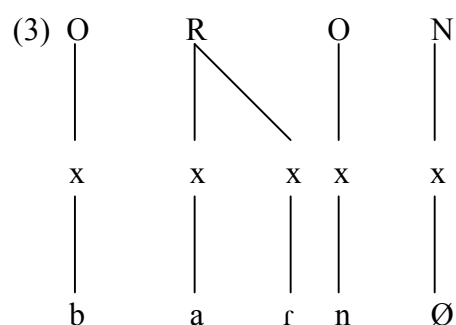

The same holds for the retroflex consonants /ʎ/ and /ʂ/. Historically, this is exactly the case. However, for some reason, the /r/ merged with the following dental in most of the Norwegian dialects. Since my analysis is restricted to the southern part of Norway, we will now try to look what happened to /r/.

Government Phonology is a highly restrictive theory which allows only two phonological processes: spreading and delinking. If we consider the representation in (2) and (3) we may assume that in the case of the retroflex consonants /ŋ/, /ʂ/ and /ʎ/ one can speak of the process of delinking: the tap assimilates with the following dental, leaving one x-slot free. The stressed nucleus requires, however, two skeletal positions, hence the vowel “takes over” the slot which is left by the /r/. In (4) we propose a representation for this process:

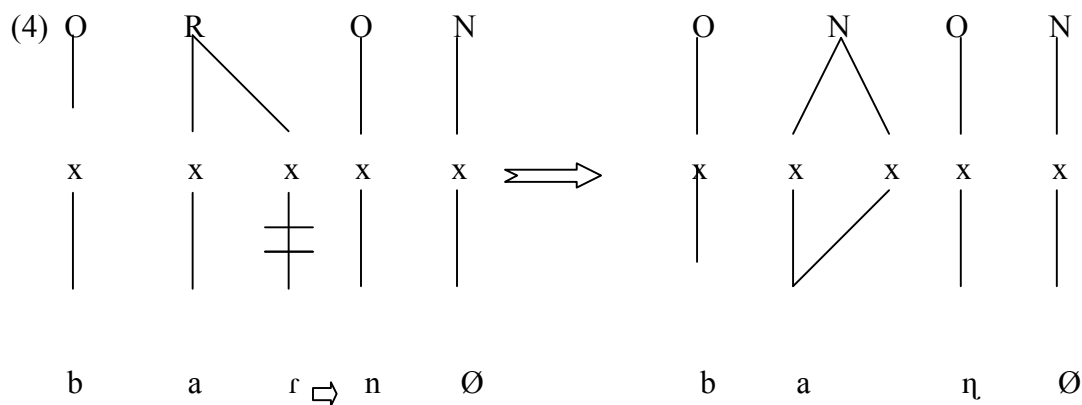

As can be observed in the representation, we deal in fact with two processes, one affecting the melodic level and the other one, which takes place on the skeletal level. On the melodic level, the melody of the /r/ merges with the melody of the /n/, giving as a result the retroflex /ŋ/. On the skeletal level there is a delinking of the /r/ from one x-slot which is then taken over by the nucleus /a/.

We have said before that a retroflex sound is a merger of a rhotic /r/ or /r̥/ plus one of the dental consonants, /n/ in the case in focus. The rhotic assimilates with the following dental; hence the consonant that emerges must contain the melodic material from both /r/ and /n/ (see HARRIS 1994 and HARRIS and LINDSEY 1995 for a discussion of elements in Government Phonology). The /r/ is a tap, i. e. a simplex, empty-headed expression containing the coronal element **A** as an operator:



The dental nasal /n/ by definition contains not only the nasal element **N** but also the stop element **ʔ**. The full representation of /n/ would be then:



As can be observed, the element that is common for both consonants is the element **A**. What follows from the merger of the rhotic and the plosive is that the element **A** of the retroflex consonant /ŋ/ “doubles”, becoming the head position in the onset¹¹:

¹¹ In this proposal we follow YOSHIDA (2001: 199) who claims that the dentals are empty-headed.

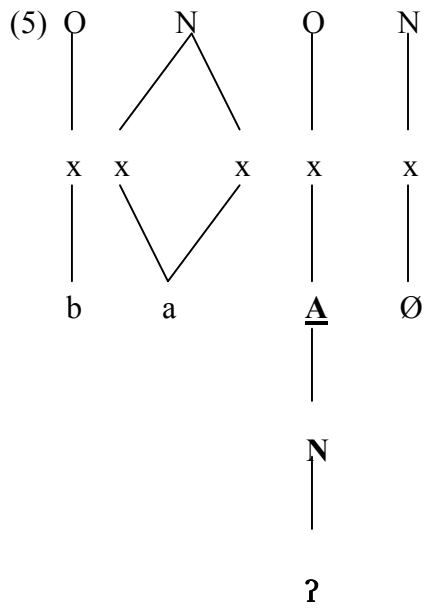

However, it should be considered that the discussion on the status of the A-element as a head of the retroflex is just a possible scenario. Following it we must say that from the phonological point of view the retroflexivization is not only a merger of two melodies, as described above, but also a process where the coronal element becomes the head of a retroflex consonant.

If one considers the examples in (1), one can see that the vowel preceding the retroflex /ʎ/ and /ʝ/ is invariably long. Hence, the same structure can be proposed.

Let us now look at the series of the two other retroflex consonants, namely *t* and *d*. Consider the examples in (6):

(6) kart [kat] (map)

fart [fat] (journey)

fort [fut] (fast)

vert [væt] (host)

hjert [jætə] (heart)

Opposite to what we saw in (1), all examples in (6) show that the vowel which precedes the retroflex [ɻ] is short. This leads us to the conclusion that in the syllabic structure the consonantal coda must be present:

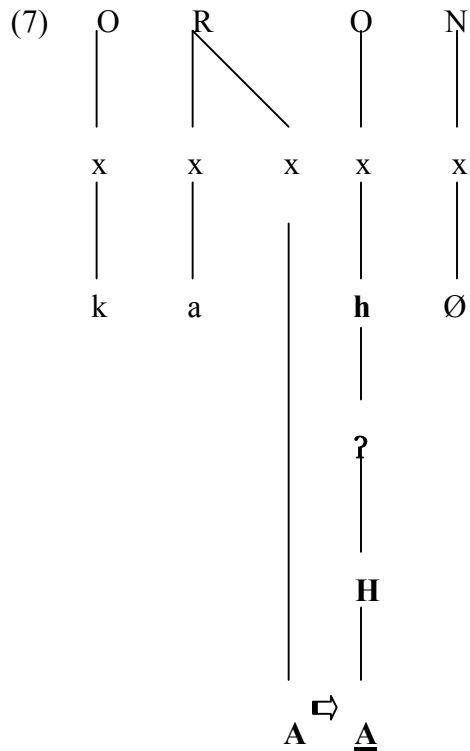

We observe that melodically one deals with the same process as in (4). The melody of the flap merges with the melody of the /t/, resulting in the retroflex /ɻ/. However, with respect to quantity, there is a clear difference in those two cases. As we remember from (4), the flap delinks from one x-slot (hence the spreading of the preceding nucleus). In (7) obviously no such process takes place. The skeletal tier remains unaffected by the retroflexivization. In fact, in the case of the merger of the /r/ with the following obstruent one can talk about gemination. The result of the merger is one melody attached to two skeletal positions, to the coda and to the onset, i.e. a true geminate:

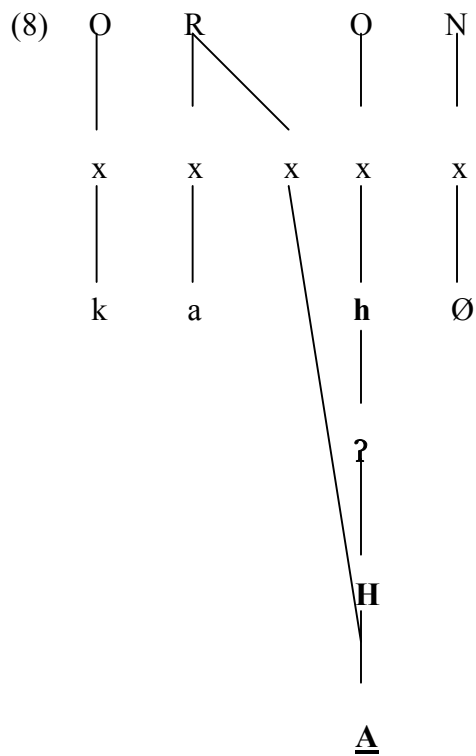

However, one has to bear in mind that all examples in (6) are monomorphemic. In cases where the flap is word-final and the suffix $-t$ is added, the situation is slightly different:

- (9) sur [sʌ:r] (sour) surt [sʌ:t] (sour, neuter)
 snar [sna:r] (quick) snart [sna:t] (quick, neuter)
 lur [lʌ:r] (smart) lurt [lʌ:t] (smart, neuter)

The word-final sonorant /r/ in the left-hand column is of course in the onset, followed by an empty nucleus. By adding the neuter suffix (which obviously is in the onset, too), we create a structure that to some extent reminds us of that in (8), with that difference that the vowel is long. The suffixation does not affect the structure of the stressed, branching nucleus. If we follow our proposal that a merger of the flap /r/ with the obstruent /t/ is a process of gemination, we can assume following representation:

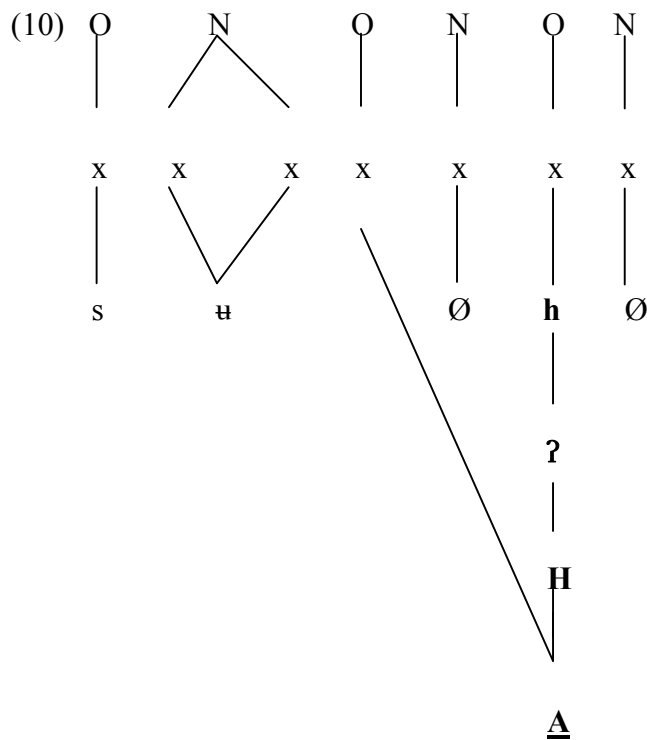

Similarly to what we saw in (7) and (8), the result of the merger is one melody attached to two skeletal slots. However, the x-slots this melody is attached to, are not adjacent on the skeletal tier, being separated by the domain-final empty nucleus. Therefore the result is a fake geminate. With respect to the syllable structure we have hence to differentiate between a retroflex /t/ in simplex and in morphologically complex forms.

What remains is the status of the last retroflex, namely the /d/. Unlike the remaining retroflex consonants, the occurrence and non-occurrence of this retroflex is strongly connected with the stress. After a stressed vowel we almost always find only [rd], while before unstressed vowels the opposite holds (KRISTOFFERSEN 2000: 89). Hence, we find obligatory *fordi* [fɔd̥i:] (because), but *garde* [gardə] (to guard). Consider the following examples (the stressed nucleus is boldfaced):

(11) *fordi* [fɔd̥i:] (because)

gardin [gɑd̥i:n] (curtain)

fordele [fɔd̥e:lə] (to share)

verdi [væd̥i:] (value)

vurdere [vuɖɐ:rə] (to evaluate)

In unstressed syllables the plosive /d/ is able to govern the preceding sonorant in a typical interconstituent government (coda-onset juncture, as perfectly possible in the dialects without the process of retroflexivization). After a stressed nucleus, however, the sonorant assimilates with the empty-headed plosive, creating a A-headed retroflex in the coda-onset position. Since the retroflex /ɖ/ almost always follows a short, non-branching nucleus, we can say that its syllabic behavior is similar to that of /t/, i.e. the retroflex /ɖ/ creates a true geminate. As far as I know, there are only a few words, where the /ɖ/ follows a long vowel, for example *lørdag* [lø:ɖag] (*Saturday*), which in fact can be regarded as a compound; hence, the difference in the syllabic position of the retroflex /ɖ/ could also be searched in morphology, just as for /t/. It would then be a fake geminate, where the two skeletal positions are separated by the domain-final empty nucleus.

Let us now turn back to the consonant discussed above, namely the retroflex consonant /t/. Unfortunately, the examples in (6) and (9) do not exhaust the possibilities of its occurrence in Norwegian. It is not impossible to find forms where no morphology can be postulated but which still behave as the forms in (9), i.e. the retroflex consonant is preceded by a long vowel. Consider just the two examples in (12):

(12) flørte [flø:tə] (to flirt)

starte [sta:tə] (to start)

In my opinion the two forms, in spite of being clearly a minority of cases, are not accidental. The data drawn from different morphological categories make it clear that there exist forms which do not follow the general rules for the quantity in Norwegian (consider the preterite forms of some weak verbs like *ba:kə* and *vra:kə* or the neuter forms of some adjectives). It seems that some consonants or consonants combinations in some lexical forms do not allow the quantity to be predictable. I will now try briefly to discuss a possible solutions to this problem. However, it shall not be considered as definitive and conclusive.

My proposal rests on the assumption that the difference between a form like *ba:kə* - *baktə* and *vra:kə* - *vra:ktə* is not in the status of the consonant juncture but in the lexical structure of the

two verb forms, or to be more precise, in the nature of the stressed nucleus. While in *ba:kə* the long /a:/ is the effect of vowel lengthening in an open syllable, the long nucleus in *vra:kə* has a slightly different origin. In fact, what seems to be a long vowel is a sequence of two short nuclei, being separated by an empty onset. Consider the following representation:

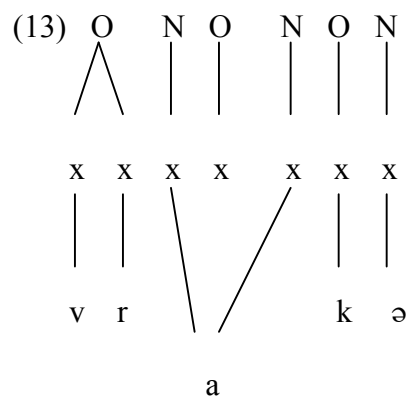

Hence, even when the consonant-initial past tense suffix is added, it has no influence on the syllable structure. No vowel shortening can take place. If we apply the same structure to the forms in (12), it will be unsurprising why the vowel is long, although, as the majority of examples shows, it should not be. The difference between the forms in (6) and (12) consists namely in the nature of the stressed nucleus. In (12) it is a sequence of two non-branching nuclei; hence, the syllabic structure is different from the one in (6):

Chapter 7. Stressed vowels in closed syllables

In the preceding chapters we discussed cases of open syllables in Icelandic and Norwegian, i.e. the situations where the stressed vowel appears as long, occupying two skeletal positions that are available in a branching rhyme. In the following lines we concentrate on the cases where only short nucleus is allowed.

Consider now the following examples:

(1) Nor. sikte [siktə] (to shift)

plante [plɑntə] (to plant)

blanke [plɑŋkə] (to polish)

kjempe [çɛmpə] (to fight)

skrifte [skriftə] (to confess)

savne [savnə] (to miss)

hest [hɛst] (horse)

Icel. pabbi [pʰap:ɪ] (daddy)

kampur [kʰɑmpʏr] (moustache)

hestur [hɛstʏr] (horse)

The examples in (1) give evidence for what we call closed syllables, i.e. the syllables where the stressed nucleus is followed by two or more consonants (unlike the traditional view, where a closed syllable includes one and more final consonants). Noticeably, all forms have a short vowel, which means that the coda consonant is present. In GP a coda consonant can only appear within a syllable structure with an onset which licenses it (The Coda Licensing Principle, c.f. KAYE 1990: 311). Hence, in every consonant cluster that causes the shortening of the stressed vowel the first consonant has to be assigned to the coda (the rhymal complement). Consider the representation for the form *kambur*:

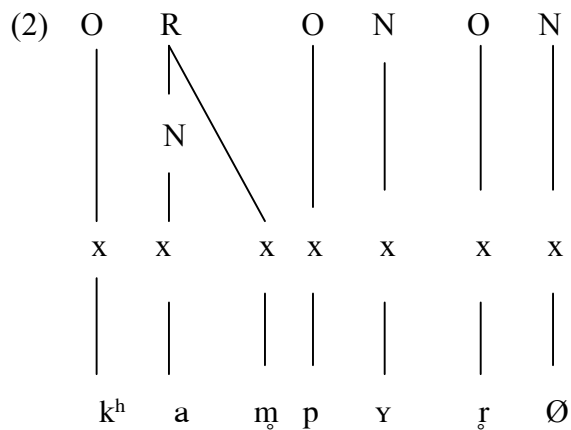

The stressed rime is branching, but, unlike in open syllables, the nucleus occupies only one skeletal position, while the other one is occupied by the rhymal complement. Since no stress is assigned to the second vowel, it is short

As was said before, a coda consonant can only be present in a syllable structure with an onset to license it. In GP a coda-onset contact is a right-head interconstituent government, where the onset governs the preceding coda.

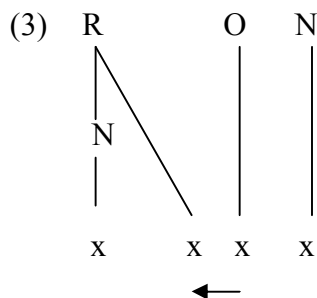

Hence, as far as the element structure is concerned, the onset consonant cannot be less complex than the coda, i.e. it has to be of the same or greater complexity. GUSSMANN (2002a: 180) lists the most typical coda-onset combinations found in Icelandic. This, as well, can be extended to Norwegian data:

- (4)
- a. sonorant – obstruent
 - b. spirant – obstruent
 - c. unaspirated plosive – sonorant
 - d. voiced spirant – sonorant
 - e. [s] – sonorant stop
 - f. sonorant – sonorant

As was mentioned earlier on, in all morphologically simple forms the vowel preceding any of these combinations is invariably short. Therefore, the first consonant in the clusters listed in (4) must occupy the rhyml complement (coda) position. Obviously, the possibilities of the coda-onset government are highly restricted.¹² For example, no aspirated plosive can be assigned to the rhyml position. If there emerges an aspirated plosive – aspirated plosive contact (due to inflection or derivation), the stressed vowel that precedes is always long, as exemplified by GUSSMANN (2002a: 181):

(5) litur [lɪ:tʰʏr̥] (colour) litka [lɪ:tʰkʰa] (vb.)

Since the two aspirated plosives cannot enter into a typical coda-onset government (due to the same segmental complexity), they are both assigned to two onsets (separated by an intervening empty nucleus). Hence, the syllable is open and the stressed nucleus is branching (long).¹³

A little more needs to be said about s+C clusters, since they behave in a peculiar way. The evidence of vowel length shows that sometimes the spirant [s] has to be assigned to the coda position and, in other cases, to the onset position. Consider the following examples:¹⁴

(6) hestur [hestʏr̥] (horse) Esja [ɛ:sja]
 flaska [flaska] (bottle) tvisvar [tʰvɪ:svar̥] (twice)
 asni [asnɪ] (ass)

We leave the examples in the right-hand column aside, since we have already discussed them in chapter 4, which was devoted to open syllables and branching onsets in Icelandic and Norwegian, and concentrate on the examples in the left-hand column. The conclusion, then, is that the coda consonant is present, as the stressed vowel is short. This means that there are some consonants that license the [s] in the rhyml complement position. According to GUSSMANN (2002a: 179), [s] is licensed in the coda by a stop in the onset. Actually, no s+C sequences can ever be tautosyllabic, as argued for instance in KAYE (1996). There are, then,

¹² The phonotactic restrictions are not subject to universal principles and have to be accounted for on the language specific basis.

¹³ GUSSMANN (2002a: 181) notes that the form in (6) admits two pronunciations, one with two aspirated plosives, as shown in (6), and one with a voiceless fricative [θ] which occupies the rhyml position, shortening the stressed vowel: [lɪθkʰa]. This issue will be discussed later on.

¹⁴ Note that the plosive preceded by [s] is invariably deaspirated (see also KRISTOFFERSEN 2000: 80ff. for a discussion on deaspiration of plosives after [s] in Norwegian)

two kinds of s+C clusters: one of the type presented in (6) in the left-hand column (i.e. coda-onset government) and the other represented by the right-hand column examples (i.e. Interonset Government, see the chapter on branching onsets in Icelandic and Norwegian).

7.1. Short vowel before geminated consonants

In Icelandic the occurrence of geminated (long) consonants is restricted to the class of the historically voiced plosives: the sonorants [l, m, n, r] and the voiceless fricatives [f, s] (c.f. EIRÍKUR RÖGNVALDSSON 1989: 48). In Norwegian both hard and soft plosives may be geminated. In phonological terms, a geminated, i.e. long consonant occupies the coda and the onset position at the same time (one melody is attached to two skeletal positions). Following what we said before, the vowel that precedes a long consonant has to be short:

(7) Icel. *kassi* [k^has:ɪ] (box)

vagga [vak:a] (to rock)

amma [am:a] (grandmother)

bolli [pɔtɪ] (cup)

Nor. *buss* [pʊs] (bus)

sikker [sik:ɔ̃] (sure, save)

vannet [van:ə] (water, Def.)

legge [lɛk:ə] (lay)

samme [sam:ə]

In (8) a structural representation of the form *kassi* is proposed:

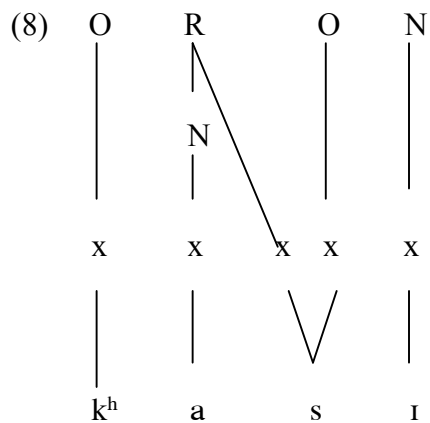

As can be seen, the difference between the representations (8) and (6) is that in (6) there are two melodies attached to two separated skeletal positions, while in (8) the same melody is attached both to the coda and the onset. The stressed nucleus cannot branch because the other available skeletal slot is occupied by a consonantal coda.

7.2. Reversible governing relations in Modern Icelandic

Modern Icelandic offers an especially instructive set of data concerning the nature of governing relations within the domain coda-onset. This issue is directly connected to the vocalic length, to which we will now devote a few remarks (based on the paper by GUSSMANN 2006c).

Let us start the discussion with the glide [j]. Although the glide cannot be a governor in an Interonset Government, it can govern certain consonants in a well-formed coda-onset contact:

(9) telja [t^hɛlja] (count)

lemja [lɛmja] (hit, strike)

verja [vɛrja] (defend)

sifjar [sɪvjar] (relations)

kveðja [kveðja] (greeting)

menjar [menjar] (relics)

The only consonants that the /j/ is not able to govern in any form are /p^h, t^h, k^h, s/. In fact, the consonants belonging to this set can never be governed so they never appear in the coda position (apart from the unpredictable behaviour of /s/, see above). The evidence of the governing potential of /j/ contributes importantly to the theory of phonology, showing that a coda-onset government requires less governing potential than the branching onset or the Interonset Government.

In chapter 4, which was devoted to branching onsets, we offered some data which show that the fricative [v] can act as a dependent in a branching onset (examples like *vökva*, *götva* and so on). In all these forms [v] [v] is a dependent of the plosive which is the head of the branching onset. However, the language provides numerous examples where [v] is governed by /j/, /ð/, /l and /r/ in the position of the rhymal complement:

(10) hafrar [havrar] (oats)

efri [ɛvrɪ]

rövla [rœvla] (talk nonsense)

sofðu [sɔvðʏ] (sleep, imperative, 2.per.sing.)

vefja [vevja] (wrap)

At the same time, other examples show that /v/ can govern /ð/, /r/ and /l/:

(11) horfa [hɔrva] (look)

vöðvi [vœðvɪ] (muscle)

Úlfar [ulvar] (proper name)

álfa [aulva] (continent)

Thus, we find reversible onset-rhyme governing relations like [vl]-[lv], [vr]-[rv], [vð]-[ðv]¹⁵. What's important in all the cases the consonants agree in voicing, i.e they are both voiced.

¹⁵ The term „reversible” does not refer to the type of government, but only to its direction so, for instance, an Interonset Government should not be regarded as a reversed form of a coda-onset government.

If we then look at the syllabic positions and hence governing abilities of the sonorant /r/, we find more evidence for the peculiar behaviour of the sonorants in Icelandic. According to what we could predict using the machinery of GP, the /r/ normally appears as a dependent, either in a branching onset, an Interonset Government or a coda onset contact. In (12) we give examples illustrating both cases:

(12) a. branching onset, after a plosive or a tone-bearing (voiceless) spirant:

krafa [k^hra:va] (demand)

brak [pra:k] (crash)

fragt [fraxt] (freight)

þrep [θre:p^h] (step)

b. Interonset Government

lausra [lœi:sra] (loose, gen. pl.)

c. coda-onset, governed by an obstruent or a non-homorganic sonorant

varpa [vaṛpa] (throw)

harma [harma] (lament)

gerð [kεrð] (kind, make)

As we said, this is fully predictable and follows from the conditions that were discussed above. Simultaneously, however, the /r/ shows its governing abilities when being an onset preceding any of the voiced spirants /ð, ɣ/ or the sonorants /v, m, n, l/. Consider the following examples:

(13) blaðra [plaðra] (chatter)

ögra [œɣra] (provoke)

hafrar [havrar] (oats, m. pl.)

glamra [klamra] (rattle)

vanrækja [vanraic^ha] (neglect)

gulra [kylra] (yellow, gen. pl.)

The short stressed vowel in all the cases doubtlessly means that the consonant preceding [r] has to be assigned to the rhymal complement position. Again, the Icelandic data provides evidence for reversible governing between sonorants: the /r/ can both govern and be governed

but only with respect to /m, ð, v/. On the assumption that a weaker consonant cannot govern a stronger one, /we conclude/ that presumably the sonorants which appear in the reversible governing relations are equally complex; however, this cannot be said about the two stop sonorants /m/ and /n/. The only governing relation between the two sonorants is the one where [n] governs [m], as shown in (13):

- (13) *gamna* [kamna] (amuse oneself)
 samning [samniŋk] (composition)
 himna [hımna] (membrane)

The relationship is not reversible, i.e. there are no words in Modern Icelandic where [m] would govern [n]. Hence, words like **ganma* or **sanming* are not only not-existing but also impossible in Icelandic. Obviously, then, the /n/ is more complex than the /m/, and it is able to act as its governor.

A rather peculiar instance of reversible governing relations appears among clusters consisting of a sonorant and a toneless plosive. Let us consider some examples illustrating a coda-onset governing relation where a sonorant in the onset governs a toneless plosive in the coda:

- (14) *efni* [ɛpni] (material)
 safn [sapn] (collection)
 treflar [tʰrɛplar] (scarf, pl.)
 þöglar [θœklar] (silent, nom. pl. fem.)

As we pointed out, the toneless plosive in the coda is a result of the spreading of the stopness element from the sonorant to the fricative in the coda. Here are some more examples showing that a toneless plosive in the coda can be governed by a sonorant in the onset.

In most of the phonetic and phonological descriptions of Icelandic the distribution of long /l/ and long /n/ is very restricted. After a stressed vowel and after a diphthong, we find a sequence of /tn/ and /tl/, instead of a long sonorant (EIRÍKUR RÖGNVALDSSON 1993: 72ff., INDRIÐI GÍSLASON and HÖSKULDUR ÞRÁINSSON 1993: 117f, 120). Consider the following examples:

- (15) brúnn [prutn] (brown, masc.)
 kalla [k^hatla] (to call)
 vænn [vaitn] (kind, masc.)
 bíll [pitl] (car)
 heilla [heitla] (enchant)
 seinn [seitn] (slow, masc.)

A long /l/ and a long /n/ can be, however, found in recent loanwords and in proper names: bolla [pɔl:a] (punch), Kalli [kal:i] (male name). However, the exact occurrence of the long, geminated sonorants is not of any importance here. On the other hand, what is realised as a toneless plosive is in fact the occlusion element ? which spreads from the stop sonorant in the onset to the coda.

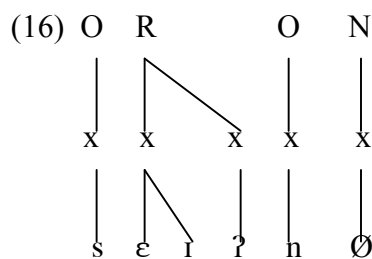

Consequently, since the coda position is occupied, the nucleus cannot branch, as attested by a short stressed vowel in all examples in (15).

We recall that a plosive in the onset governing a sonorant in the coda is one of the most typical coda-onset junctures in Modern Icelandic. Once again, we find out that Icelandic sonorants enter into complicated reversible governing relations.

It is obviously not accidental that the reversible governing relationships can only be found among the class of sonorants and sonorants in contact with toneless obstruents. It seems that sonorants have a very special position in the phonological system of Modern Icelandic (for an extensive phonetic and phonological description see ÁSTA SVAVARSDÓTTIR 1984), and, as shown in REISS (1994, 1997) also in Old Icelandic.

Chapter 8. On a double agent in Icelandic phonology- the story of [s]

The phonological behaviour of the Icelandic voiceless spirant /s/ and its syllabic affiliation are in many ways challenging to the phonological theory. Let us now have a look at the governing properties of the /s/.

In a coda-onset relation the /s/ can be governed either by an obstruent or a sonorant:

(1) *flaska* [flaska] (bottle)

prestur [p^hrɛstʏr] (priest)

ösp [œsp] (aspen)

nasla [nasla] (nibble, snack)

leysni [leisnɪ] (resolution)

hismi [hɪsmɪ] (chaff)

At the same time /s/ shows enough (governing) potential to act as a governor for a sonorant or a spirant in the rhymal complement position:

(2) *hreinsa* [rɛinsa] (clean)

falsa [falsa] (forge, falsify)

gams [kams] (vulture, Gen.Sg.)

krafsa [k^hrafsa] (scratch)

buxur [pʏxsʏr] (trousers)

liðsemd [liðsemt] (assistance)

Noticeably, some of the coda-onset relations are reversible, which obviously means that the spirant /s/ has the same complexity as the sonorants.

The spirant /s/ can also enter into Interonset Government relations, where the second onset is occupied either by the /v/, /r/ or /j/ and where the cluster causes the lengthening of the preceding vowel (cf. chapter 3 on open syllables and chapter 4 on branching onsets):

(3) Ísrael [i:sraeɪ]

tvisvar [t^hvi:svar] (twice)

flysja [flɪ:sja] (peel)

As we suggested in the chapters devoted to the question of open syllables and branching onsets, the clusters /s/ + /v, r, j/ constitute evidence for Interonset Government, where both consonants belong to separated onsets with an intervening empty nucleus. We also argued that the Interonset Government is a left-head governing relation, which in the discussed case means that the spirant /s/ is a governor for the fricative /v/, the sonorant /r/ and the glide /j/.

It has been shown earlier on by means of the governing relationships that the /s/ is able to act both as a governor in the onset position or a governee in the coda. We must conclude, then, that the /s/ can stand in the onset only when it follows a sonorant or a spirant, or when it governs /v, j, r/ in an Interonset Government. In the previous discussion we have excluded the /s/ from the governor position in a branching onset, and similarly it has to be abandoned from the dependent position within such a structure (recall the complete absence of word-initial C+s clusters in Icelandic).

One more governing relation excludes the /s/ from the governor position, namely the contact with the “strongest” of Icelandic consonants - the hard, aspirated plosives /p^h, t^h, k^h/. Preceding any of these consonants, the /s/ is automatically assigned to the rhymal complement position. A coda-onset relation, with the /s/ acting as a governor for the aspirated plosives, is also totally excluded. To support this analysis with convincing examples, we will examine some Icelandic nouns in the genitive.

8.1. The genitival –s

The –s-ending in the genitive is the unmarked ending for the strong masculine nouns and all strong neuter nouns in Icelandic (c.f. EIRÍKUR RÖGNVALDSSON 1990). Here are some examples:

(4) heim [hei:m] (home)	heims [hɛims]
mál [mau:l] (language)	máls [mauls]
búr [pu:r̥] (cage)	búrs [purs̥]
lyf [lɪ:v] (medicine)	lyfs [lɪfs]
boð [pɔ:ð] (message)	boðs [pɔðs]

In the left-hand column examples the word-final consonant is the onset licensed by the following empty nucleus; hence, the stressed vowel can branch (open syllable lengthening). The long stressed vowels alternate with the short vowels in the right-hand column. This is a simple confirmation of what we have already said: when the coda position is occupied, the stress nucleus cannot branch, i.e. only a simplex nucleus is possible. Consider the following representation illustrating the vowel length alternation in [lɪ:v] - [lɪfs]:

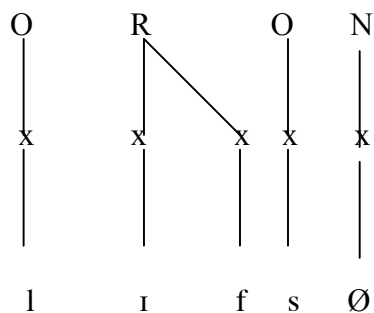
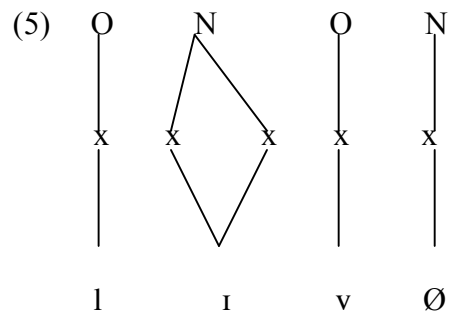

Summing up: if two consonants meet the criteria for creating a coda-onset structure, they are syllabified as such, and a short vowel results. Hence, all the stem-final consonants in the left-hand column in (4) can act as dependents of the /s/ in the onset and they occupy the rhymal complement position, leaving no free x-slot for the nucleus to branch. Again, since no resyllabification is possible, we opt for two different phonological shapes of the same form: one with the sonorant or fricative in the onset and the other one with the sonorant/fricative in the coda.

However, if the stem ends in any of the aspirated plosives /p^h, t^h, k^h/, we could expect that no coda-onset relation results. As the following examples show, this assumption proves true:

- | | |
|---------------------------------------|----------------------------|
| (6) skap [ska:p ^h] (mood) | skaps [ska:ps]/[skafs]???? |
| skip [scr:p ^h] (ship) | skips [scr:ps]/[scifs] |
| flet [flɛ:t ^h] (bunk) | flets [flɛ:ts] |
| þak [θa:k ^h] (roof) | þaks [θa:ks]/[θaxs] |

The aspirated plosives are too strong to be governed by the sonorant /s/; therefore they “remain” in the position of the onset. Predictably, the vowel before the onset lengthens. Since no branching onset consisting of C+s is possible, the plosive and the following /s/ have to be assigned to two separate onsets, with an empty nucleus intervening between them. Consider the following representation for [θa:k^h] - [θa:ks]:

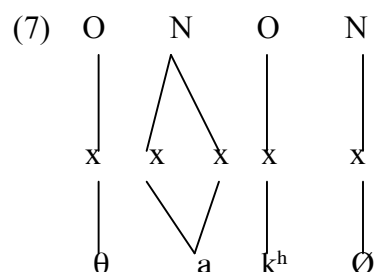

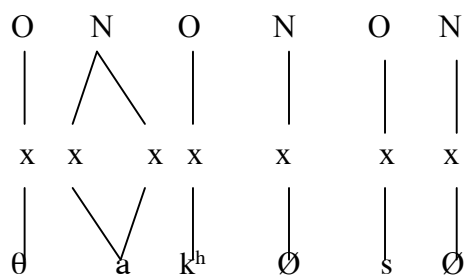

Conspicuously, the language controls both the possible and impossible (or unfavourable) governing relations. Wherever a coda-onset governing relation is possible to be established, the consonants in question enter into it, with all following consequences, like the shortening of the stressed vowel for instance. It seems that coda-onset governing is more favourable and more natural in Modern Icelandic. However, if such contact is not possible because of the complexity difference between the affected consonants, the coda-onset relation is replaced by the Interonset Government, which seems to be less favourable, possibly due to the fact that it involves additional empty nuclei that have to intervene between the consonants.

What makes us claim that the coda-onset government is more natural in Icelandic than the Interonset Government? One instance of an interesting phonological process shows that the language tends to replace the Interonset Government by the more preferable coda-onset government. In the right-hand column examples in (6) we show that in some cases two pronunciations of the genitive forms are possible, one with an aspirated plosive and a long vowel and the other one with a fricative and a short vowel. Let us have a look at the so called spirantisation rule of the plosives in Modern Icelandic.

8.2. Spirantisation of the plosives

We will examine now at three of the numerous morphological categories of Modern Icelandic, namely the genitive of strong masculine and neuter nouns and adjectives, past tense of some weak verbs and the neuter form of adjectives. As we will see, the three categories show very clearly which strategy/(ies) the language chooses when a coda-onset contact between two consonants cannot be established.

In (8) we present examples covering the three distinct morphological categories which were selected for our analysis:

(8) a. genitive -s

skip [scr:p ^h] (ship)	skips [scr:ps]/[scrfs]/[scips]
bak [pa:k ^h] (back)	baks [pa:ks]/[paxs]/[paks]
bátur [pau:t ^h ʏr] (boat)	báts [pau:ts]/[paus:]
slíkur [sli:k ^h ʏr] (such)	slíks [sli:ks]/[slixs]/[sliks]

b. past tense (+*ti*)

kaupa [k ^h œi:p ^h a] (to buy)	keypti [c ^h εifti]
vaka [va:k ^h a] (be awake)	vakti [vaxti]
gapa [ka:p ^h a] (gape)	gapti [kafti]
æpa [ai:p ^h a] (scream)	æpti [aifti]

c. neuter form of adjectives (+ *-t*)

spakur [spak ^h :ʏr] (wise, masc.)	spakt [spaxt]
djúpur [tju:p ^h ʏr] (deep, masc.)	djúpt [tjuft]

In all those examples we see that due to morphology some peculiar consonant sequences emerge (or would emerge, rather, but they don't). In (8a) the word-final aspirated plosive occupies the onset position, with the lengthening of the preceding vowel. However, in the genitive forms the plosive is followed by the spirant /s/, which, of course, is not able to govern the aspirated plosive. Similarly, in the past tense of the named weak verbs one could expect a stem-final plosive to meet the plosive /t/ that is initial in the past tense suffix. However, this does not happen. And finally, in the neuter forms of the adjectives the stem final plosive should enter into a governing relation with the following plosive in the neuter adjectival marker. Again, this does not happen.

The evidence from different morphological categories clearly shows that the process which really happens is not accidental. As we see, wherever a sequence of two aspirated plosives is expected (or a plosive and /s/), the first plosive is replaced by its spirant congener:

(9) /ps/ > /fs/

/ts/ > /s:/

/ks/ > /xs/

/kt/ > /xt/

/pt/ > /ft/

This general rule holds not only for the morphological categories mentioned above but also for the so-called medio-passive, imperative and past participle of weak verbs (c.f. EIRÍKUR RÖGNVALDSSON 1993: 69). It is also important to note that the plosive followed by the fricative in such sequences is unaspirated (INDRIÐI GÍSLASON and HÖSKULDUR THRÁINSSON 1993: 78), which is presumably due to a general constraint disallowing aspirated plosives after consonants (GUSSMANN 2002a: 135). What does the spirantisation of the plosives mean with respect to vowel length and syllabic affiliation of the affected consonants? First of all, there is a vowel length alternation: in all examples in the left-hand column the stressed vowel is long, which is unsurprising since it occurs in an open syllable. In the examples in the right-hand column the vowel is invariably short, which must mean that the following fricative has to be assigned to the position of the rhyml complement. As a result we find a typical coda-onset governing relation, where the more complex and phonologically stronger plosive in the onset governs the less complex and weaker fricative in the coda:

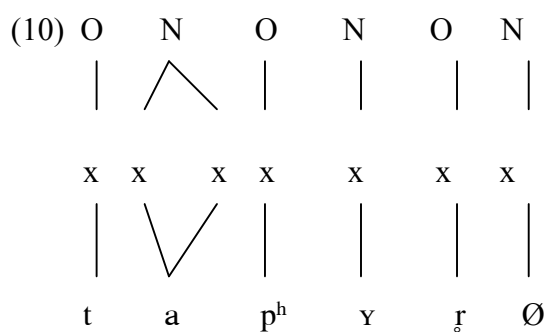

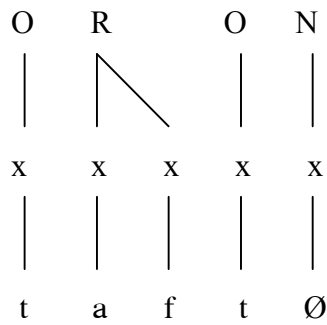

In (8a) we showed, however, that Modern Icelandic allows two or even three different pronunciations of the same form: one with a plosive replaced by a fricative and the other one where no change in the melodic content of the plosive takes place. Hence, the resulting structure contains a plosive followed by the spirant /s/. As we said many times before, such a sequence is not a possible coda-onset contact, since the spirant is too weak to govern an aspirated plosive. This is also supported by the fact that the vowel is long; therefore, the plosive is excluded from the rhymal complement position. Logically, since the plosive and the spirant cannot create a coda-onset juncture (nor a branching onset either), they have to be assigned to two separate onsets, with an empty nucleus between them and no alternation in the length of the vowel. Consider the following representation:

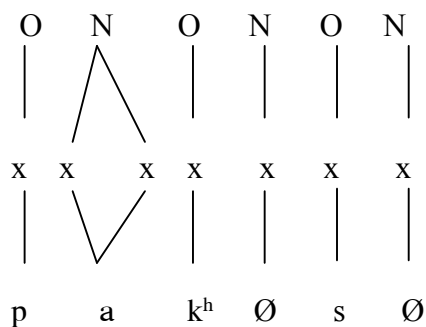
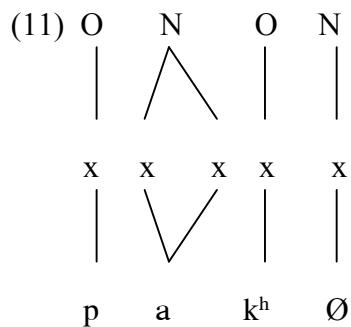

We are confronted with an Interonset Government, which, as we have seen before, is a perfectly possible (sometimes even the only possible) structure in Modern Icelandic. However, since the Interonset Government requires additional empty nuclei to act, the language prefers the coda-onset governing relation. To achieve a relation like this, the plosive is lenited to its spirant congener. The role of the spirantisation, therefore, is to prevent the aspirated plosives from occurring in the position of the rhymal complement. The possible scenario of what happens to the melody of the plosive is that it is deprived of its stopness element ? . As a fricative it can be of course governed by the following plosive or the spirant /s/ in a well-formed coda-onset relation.

Chapter 9. Phonology vs. morphology - vocalic quantity in Icelandic compounds and derived words

So far we have tried to show the regularities conditioning the appearance of long and short nuclei Icelandic and Norwegian. The analysis has been based on the following assumptions:

(1)

- a. vocalic quantity is not phonemic and not-distinctive neither in Icelandic nor in Norwegian, i.e. lexically there are only short vowels in Icelandic (see however KRISTJÁN ÁRNASON 1998 for a different view)
- b. stressed rhymes must branch, either in form of a branching nucleus (a long vowel) or a simplex nucleus followed by a consonantal coda
- c. stressed vowels are long only when no coda consonant is present
- d. followed by two or more consonants the vowels can only be short (with the exception of clusters discussed in chapter 4)

In this section we would like to look at vowel length in compounds and derived words. As we will see, the rule which we have worked out is obviously violated, which makes the general quantity rule anything but a “phonological simpleton” (cf. GUSSMANN 1982: 307).

There exists a considerable number of different conflicting proposals concerning the irregularities found in the compounds and derived words. Different mechanisms have been used to account for the complicated facts: referring to morphological structure (KRISTJÁN ÁRNASON 1980), the weakening of syllable boundaries (GUSSMANN 1985) or manipulating with ordering constraints (GIBSON 1997). None of them, however, seems to satisfy the explanatory requirement for a comprehensive analysis. MAGNÚS PÉTURSSON’s attempt of finding some logic in the system (MAGNÚS PÉTURSSON 1978: 47f.) is not satisfactory either. We will then propose an alternative view on compounds and derived words, drawing from Government Phonology’s claim that phonological analysis should be solely based on phonological information (cf. KAYE 1995). This has been convincingly developed for Icelandic in GUSSMANN (2002a: 181ff).

The analysis we develop in this study enables us to account for another group of compound words, namely compounds where the first member ends in an aspirated plosive:

- (4) leikdómur [lei:k^htómʏr] (drama review) leika [lei:k^ha] (play) + dómur [tɔu:mʏr]
(judgment)
- skapgerð [ska:p^hcærð] (personality) skap [sk:p^h] (temper) + gerð [cærð]
(structure)
- matbúa [ma:t^hpua] (cook) matur [ma:t^hʏr] (food) + búa [pu:a] (prepare)

We have shown frequently before that the aspirated plosives /p^h, t^h, k^h/ can never occupy the position of the rhyml complement (they can only be projected as onsets). Consequently, also in compounds the aspirated plosive has to “remain” in the position of the onset forcing the preceding vowel to lengthen.

Let us now examine a few assumptions concerning stressed vowel lengthening in derived words. If the rule of vowel lengthening in Modern Icelandic is right, it will apply not only to morphologically simple words and compounds, but also to forms effecting from morphology of the language. Previously we showed that the same regularities that can be found in simplex words hold ending –s for the genitive. In (5) we provide examples for adjectives in their main form (nominative singular masculine) and with three suffixes: -ri for the dative singular feminine, -rar for the genitive singular feminine and –ra for the genitive plural (cf. GUSSMANN 2002a: 170ff):

- (5) gulur [ky:lʏr̥] (yellow) gulri [kylri] gulrar [kylrar̥] gulra [kylra]
- glaður [kla:ðʏr̥] (glad) glaðri [klaðri] glaðrar [klaðrar̥] glaðra [klaðra]
- slæmur [slai:mʏr̥] (bad) slæmri [slaimri] slæmrar [slaimrar̥] slæmra [slaimra]

It is not surprising that in the examples in the first column the vowel is long, since the single consonant belongs to the onset, leaving the syllable open. In all the declined forms, however, the vowel is consequently short before a consonant cluster, which means that the first

consonant of the clusters occupies the position of the rhymal complement. If we recall possible coda-onset combinations in Icelandic, we will see that it is a simple confirmation of our assumptions: since the sonorant /r/ in the onset is able to govern respectively the sonorant /l/, the fricative /ð/ and the sonorant /m/ in the coda, they are syllabified as such. The short vowel in all the cases follows automatically from the presence of the coda consonant in the branching rhyme.

The examples provided so far prove that very little, if any, morphological information is necessary for the purpose of phonological considerations. In all the cases discussed above the lengthening or shortening of the stressed vowel follows directly from the conditions which govern the presence or absence of a long vowel (and which we summarized in (1)): if there is no coda consonant in the syllabic structure, the vowel lengthens. When the second x-slot in the branching rhyme is occupied by a coda consonant, the vowel can only be short. No additional reference to the morphological structure of the form in question is needed, nor taking into account syllable- or word-boundaries. To phonology it does not matter whether the word is morphologically simplex, complex or if it is a compound. Phonological interpretation must be based primarily on phonological, not morphological evidence (cf. GUSSMANN 2002a: 171). In other words, phonology is not driven by morphology.

What are, then, the violations we mentioned in the opening part of this section? Once again we must turn back to the double agent of Icelandic phonology, namely the spirant /s/.

9.1. More about the double nature of /s/

In the previous chapter we concentrated on the governing potential and syllabic affiliation of the voiceless spirant /s/. We showed that it can be both a governor and governee, depending on the environment and acting as a kind of phonological double agent. It can be governor when preceded by a fricative or a sonorant (coda-onset government) or when preceding /v/, /j/, /r/ (Interonset Government). The /s/ can also act as a governee in the coda, when followed by a sonorant or an obstruent. Before we try to explain this ambiguity, we will examine syllabic behavior of /s/ in compounds. Consider the following examples (cf. GUSSMANN 2002a: 191):

- | | |
|--|---------------------------------------|
| (6) brosmildur [prɔ:smiltʏr] (smiling) | gjafmildur [cavmiltʏr] (generous) |
| brosgjarn [prɔ:scartŋ] (funny) | góðgjarn [kəuðcartŋ] (gracious) |
| ljóðsfræði [ljɔu:ðsfraiðr] (optics) | málfræði [maulfraiðr] (grammar) |
| ljósmóðir [ljɔu:sməuðr] (midwife) | formóðir [fɔrməuðr] (female ancestor) |
| Ísland [i:slant] (Iceland) | Írland [irlant] (Ireland) |

The examples in the right-hand column show typical coda-onset combinations with the stressed short vowel as a result of the presence of the coda consonant in the syllable structure. In the left-hand column, on the other hand, where in all examples the first member of the compound is the spirant /s/, the stressed vowel is long, despite of the following consonant clusters which should make the vowel short. To account for the syllabic structure of the examples in the left-hand column, one has to introduce additional empty nucleus intervening between the spirant and the following consonant:

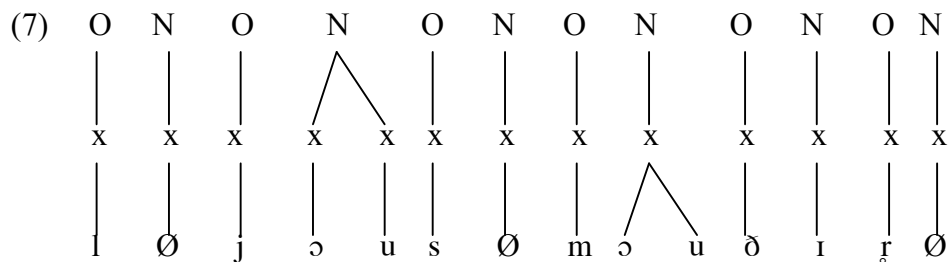

Naturally, no additional empty nuclei are needed for the forms in the right-hand column, because the consonant clusters there constitute coda-onset government.

Since the second member of the compounds is the same in both the left-hand and the right-hand column examples, we have to conclude that it is the nature of the spirant /s/ that is different. Numerous examples show that the spirant occupies the position of the rhymal complement being a member of exactly the same consonant clusters as we find in (6). Hence, in some cases the /s/ is projected as the coda and sometimes as the onset, even if the same consonant follows. This let GUSSMANN (2002a: 191) conclude that *s is special*, because it *systematically if unpredictably* admits of double syllabification (emphasis his).

Strikingly, in many respects the spirant /s/ behaves exactly in the same way as the “strongest” Icelandic consonants, namely the aspirated plosives /p^h, t^h, k^h/ (e.g. the

lengthening clusters consisting of /p^h, t^h, k^h, s/ and /v, j, r/). Hence, it could be useful to compare the properties of the aspirated plosives with the ones of the spirant /s/

In Government Phonology, as said before, it is generally agreed that in the Germanic languages it is the high tone element H that is responsible for voicelessness and preaspiration (cf. HARRIS 1994: 133ff., GUSSMANN 2000: 96ff., GUSSMANN 2002b, BLOCH-ROZMEJ 2008: 91ff.). It is not accidental that aspiration in Icelandic involves only hard (i.e. historically voiceless) plosives. It is precisely the effect of the presence of the element H in the melodic make-up of the plosives /p^h, t^h, k^h/. Supposedly, the element H prevents the aspirated plosives from occurring in the position of coda (recall that aspirated plosives are completely absent from this syllabic position and can only be projected as onsets). On the other hand, the historically voiced plosives, spelled as *b, d, g* (in our transcription /p, t, k/), which are never aspirated and therefore lack the element H, can be assigned to the position of the rhyml complement. In English, for example, the absence of the source element H is connected with the voicing of the consonant in the question, something that is missing in Icelandic. Hence, two phonetically identical segments in Icelandic can be different from the phonological point of view:

(8) a. epli [ɛhplɪ] (apple)

b. treflar [t^hrɛplar] (scarfs)

In both examples we find a sequence of the plosive /p/ followed by the lateral /l/. Phonetically there is no difference between the two clusters; they are realised in exactly the same way. However, phonologically we have to do with two different clusters, or to be more precise, with two different plosives: in (8) the cluster is preceded by preaspiration, which means that the plosive has to contain the element H, which is realised as preaspiration in the context of /p^h/ preceding /l/. GUSSMANN (2000b) calls this case “contextual realization of an aspirated [plosive]”. Since no preaspiration occurs before the phonetically same cluster in (8b), we have to conclude that the plosive does not contain the source element H (in fact, the plosive is a result of the spreading of the occlusion element from the sonorant in the onset to the preceding fricative).

If we should now transfer the characteristics we established for the Icelandic aspirated plosives to the spirant /s/, our proposal would have to be that the spirant also contains the element H. The presence of the high tone element in the melodic content of /s/ is the reason

why the spirant is never voiced in Icelandic (nor in any of the closest relatives of the language, like Norwegian or Faroese, in fact). This makes the appearance of /s/ in the onset possible, even in the cases where the following consonant should be able to govern /s/ in the position of the rhyml complement (recall the examples in (6)). Further on, we saw frequently that the spirant can occupy the position of the rhyml complement. Following what we said about aspirated and unaspirated plosives, we conclude that if the spirant /s/ occurs in the coda, it cannot contain the element H then. It is not possible at this stage of our study to decide why the spirant contain the element H in some cases, but lacks it in other cases. The only thing we can say about it now is that we possibly deal with two different phonological objects, “two /s/’s”, even when pronounced in exactly the same way.

Naturally, the role of the element H in the melodic content of /s/ is different from that in the aspirated plosives, which can be concluded from the fact that the spirant is neither aspirated nor preaspirated. However, with respect to governing possibilities and the syllabic affiliation the similarities between the Icelandic aspirated plosives and the voiceless spirant /s/ are significant.

Chapter 10. The phonology of past tense in Norwegian and Icelandic

In the following sections an attempt will be made to give a phonological description of the past tense Norwegian and Modern Icelandic: some principal differences between the two languages can be found, both regarding the creation of the past tense and its phonological consequences. An analysis of the data will demonstrate two different strategies of the languages in question in conforming to more general phonological rules which govern the systems of Norwegian and Icelandic.

10.1. Past tense in Norwegian – data and problems

In Norwegian, just as in other Germanic languages, the past tense of weak verbs is created by the addition of a dental suffix to the stem of the verb. Historically, the dental suffix goes back to the fully inflected form of the Indo-European verb ‘to do’, which was added to the weak verbs along with the suffix /j/ to mark past tense. Later the root of the verb became a suffix and is now present as the productive tense marker in all the Germanic languages. For this view see LAHIRI (2000: 91).

As can be found in textbooks and grammars on Norwegian (cf. BERULFSEN 1967: 144ff., FAARLUND et al. 1997: 481ff), the past tense of weak verbs appears in different surface variants, depending, roughly speaking, on the voicing context and on the number of consonants in which the verb terminates. For verbs terminating in a single consonant or a consonant cluster (or a geminate), the suffix is either *-et/a*, *-te* or *-de*. If the verb ends in a long stressed vowel (in monosyllabic words), the past tense suffix is *-dde*. Consider first some introductory examples:

(1a) kast-e [kastə] (to throw)	kast-et [kastət]
melk-e [mɛlkə] (to milk)	mɛlket [mɛlkət]
bedr-e [pɛ:trə] (to improve)	bedr-et [pɛ:trət]
sykl-e [sy:klə] (to ride a bike)	sykl-et [sy:klət]
(1b) strekk-e [strɛk:kə] (to stretch)	strek-te [strɛktə]
meld-e [mɛ:lə] (to announce)	meld-te [mɛltə]

send-e [sen:ə] (to send)	send-te [sɛŋtə]
(1c) hvil-e [vi:lə] (to rest)	hvil-te [vi:ltə]
smør-e [smø:rə] (to lubricate)	smør-te [smø:tʰə]
(1d) bak-e [pa:kʰə] (to bake)	bak-te [pakʰtʰə]
måp-e [mo:pʰə] (to gape)	måp-te [mo:pʰtʰə]
(1e) prøv-e [prø:və] (to try)	prøv-de [prøvdə]
lag-e [la:kə] (to make)	lag-de [laktə]
bøy-e [pøjə] (to bow)	bøy-de [pøjtə]
(1f) bo [pu:] (to live)	bu-dde [putə]
kna [kɲa:] (to knead)	kna-dde [kɲatə]

This very introductory set of examples allows us to formulate some basic principles which govern the distribution of the past tense suffix in Norwegian. Thus, the suffix *-et* is added when the stem of the verbs ends in a consonant cluster (1a). The suffix *-te* appears when the stem of the verb ends in a geminate (1b), a single sonorant (1c), and a single voiceless (i.e. aspirated) obstruent (1d). The toned variant of the suffix (*-de*) is chosen when the stem of the verb terminate in a non-aspirated obstruent or a glide (1e). Monosyllabic verbs terminating in a long stressed vowel choose the *-dde* variant of the dental suffix (1f).

From the above generalisation we can gather that there are actually two criteria which have to be taken into consideration when forming and analysing the past tense of weak verbs in Norwegian: the stem-final environment (i.e. whether we deal with a consonant cluster, a geminate or a single postvocalic consonant) and the voicing of the stem-final consonant. All this will be discussed in the following sections.

Let us begin the discussion with verbs that choose the *-et* variant of the past tense suffix. In the following presentation the verbs are grouped according to the stem-final environment (FAARLUND et al. 1997: 482f.)¹⁶:

(2) [-rd], [-vd], e.g. hevd-e [hɛvtə](claim)	hevd-et [hɛvtət]
herd-e [hɛrtə] (harden)	herd-et [hɛrtət]
[-lg], [-rg], e.g. svelg-e [svɛlkə] (swallow)	svelg-et [svɛlkət]

¹⁶ Although this particular suffix does not induce any alternations in the length of the stem vowel between the infinitive and the past tense form, we will devote some time to this problem, since it leads to interesting conclusions. As we said above, for all these verbs the past tense suffix can be either *-et* or *-a*. The choice of the particular form of the suffix depends very much on the speaker, his/hers geographical and social background and style (KRISTOFFERSEN 2000: 209). The form *-a* is regarded as the most radical variant of the suffix.

farg-e [farkə] (dye) farg-et [farkət]
 [-lj], [-nj], [-rj], [-tj], e.g. olj-e [ɔljə] (oil) olj-et [ɔljət]
 ferj-e [ferjə] (ferry) ferj-et [ferjət]
 vitj-e [vitjə] (?) vitj-et [vitjət]
 [-lk], [-ŋk], [-rk], [-sk], e.g. melk-e [mɛlkə] (milk) melket [mɛlkət]
 blink-e [ppliŋkə](blink) blink-et [pliŋkət]
 virk-e [viɾkə] (work) virk-et [viɾkət]
 husk-e [hʊskə] (remember) husk-et [hʊskət]
 [-bl], [-dl], [-fl], [-gl], [-kl], [-ml], [-pl], [-fl], [-tl], [-vl], e.g.
 sabl-e [sa:plə] (to cut down) sabl-et [sa:plət]
 sykl-e [sy:klə] (ride a bike) sykl-et [sy:klət]
 saml-e [samlə] (collect) saml-et [samlət]
 avl-e [avlə] (build on) avlet [avlət]
 kopl-e [kʰɔplə] (combine) kopl-et [kʰɔplət]
 [-lm], [-rm], e.g. falm-e [falmə] (fade) falm-et [falmət]
 varm-e [varmə](warm) varm-et [varmət]
 [-tn], [-kn], [-kŋ], [-ln], [-pŋ], [-rn], [-sn], [-tŋ], [-vn], e.g.
 modn-e [mo:tnə] (ripen) modn-et [mo:nət]
 våkn-e [vo:kŋə] (wake up) våkn-et [vo:kŋət]
 visn-e [visnə] (wilt) visn-et [visnət]
 stivn-e [stivnə] (grow stiff) stivn-et [stivnət]
 [-mp], [-rp], [-sp], e.g. lemp-e [lɛmpə] (moderate) lemp-et [lɛmpət]
 terp-e [tæɾpə] (swot up) terp-et [tæɾpət]
 gjesp-e [jɛspə] (yawn) gjesp-et [jɛspət]
 [-pr], [-tr], [-fr], [-kr], [-kɾ], [-mr], [-tɾ], e.g.
 svabr-e [sua:prə] (swab) svabr-et [sua:prət]
 bedr-e [pe:trə] (improve) bedr-et [pe:trət]
 ofr-e [ɔfrə] (offer) ofr-et [ɔfrət]
 lagr-e [la:krə] (store) lagr-et [la:krət]
 snekr-e [sne:kɾə] (do woodwork) snekr-et [sne:kɾət]
 hamr-e [hamrə] (hammer) hamr-et [hamrət]
 sutr-e [sʊ:tɾə] (whimper) sutr-et [sʊ:tɾət]
 [-fs], [-ks], [-ms], [-ns], [-ps], [-ts], e.g.

krafs-e [kraf̥sə] (scratch)	krafs-et [kraf̥sət]
flaks-e [flaksə] (flutter)	flaks-et [flaksət]
brems-e [p̥rɛmsə] (brake)	brems-et [p̥rɛmsət]
dans-e [tansə] (dance)	dans-et [tansət]
tips-e [tipsə] (tip)	tips-et [tipsət]
sats-e [satsə] (bring into action)	sats-et [satsət]

[-ft], [-kt], [-lt], [-mt], [-nt], [-st], e.g.

heft-e [hɛftə] (pin)	heft-et [hɛftət]
lukt-e [lʉktə] (smell)	lukt-et [lʉktət]
velt-e [vɛl̥tə] (roll)	velt-et [vɛl̥tət]
kast-e [kastə] (throw)	kast-et [kastə]

[-lv], [-rv], e.g. salv-e [salvə] (anoint) salv-et [salvət]

arv-e [arvə] (inherit) arv-et [arvət]

A closer examination of the examples above allows us to group this apparently chaotic group into two subsets of verbs. Our point of departure in doing so will be the governing relations that can be recognized in the stem-final environment. It is easy to notice that the consonant clusters in which the verbs in (2) terminate constitute two particular syllabic structures. Thus, one finds a typical coda-onset juncture on the one hand (in the majority of examples) and well-formed branching onsets, on the other hand. The possible coda-onsets contacts in Norwegian can be further generalized as follows:

- (3) sonorant + obstruent, e.g. velte [vɛl̥tə] (upset), terpe [tæ̥rpə] (cram), [p̥rɛmsə] (brake)
obstruent + obstruent, e.g. lukte [lʉktə] (smell), kaste [kastə] (throw), tipse [tipsə] (tip)
obstruent + sonorant, e.g. kople [kɔp̥l̥ə] (couple), ofre [ɔfrə] (sacrifice)
sonorant + sonorant, e.g. samle [samlə] (collect), hamre [hamrə] (hammer), falme [falmə] (fade)

All verbs ending in one of the clusters given above choose the vowel-initial past tense suffix *-et*.

The same happens, however, when the verb ends in a sequence of two consonants that constitute a branching onset, as in the verbs like *svabre* [sva:p̥rə], *bedre* [p̥ɛ:trə], *lagre* [la:krə], *snekre* [sne:krə], *sutre* [sʉ:trə]. Also in the case of these verbs, the past tense suffix is

vowel-initial. Translating this into government terms, we can conclude that in the past tense all coda-onset contacts (apart from true geminates to which we will return below) and branching onsets have to be licensed by a phonetically realised vowel of the past tense suffix. In the case of verbs ending in a coda-onset combination, the nucleus licenses the onset and allows it to govern the consonant in the coda (licence to govern). As for the verbs terminating in a branching onset, the presence of the phonetically realised nucleus is absolutely required, since Norwegian (unlike e.g. Icelandic) does not allow branching onsets before an empty nucleus. Hence forms like *[pe:tr] or *[sva:pr] are totally ruled out by the rule disallowing word-final branching onsets. A more general theoretical conclusion that follows from this observation will be that a coda-onset juncture is easier to license than a branching onset. This serves as an argument for our more general assumption about the restricted licensing properties of empty nuclei. Interestingly, a whole bunch of examples can be found where an empty nucleus licenses a coda-onset juncture (e.g. *salt* [sałt] (salt), *hjelp* [jɛlp] (help)), whereas its licensing abilities are far more restricted with respect to branching onsets, since, as we noticed above, they require a phonetically realised vowel. Before going any further with the analysis of the past tense, we will devote a little more time to licensing properties of empty nuclei in Norwegian.

10.1.1. Excursion – geminates and licensing abilities of empty nuclei

We noticed above that non-initial branching onsets in Norwegian require a full (i.e. a phonetically realised) vowel to license them. With respect to the coda-onset juncture, the situation is slightly more complex. Consider the following examples:

- (4) *land* [lan] (land), not *[lan:]
 mett [mɛt] (full, well-fed), not *[mɛt:]
 klepp [klɛp] (lump), not *[klɛp:]
 kall [kal] (call), not *[kal:]
 narr [nar] (fool), not *[nar:]

grim [krim]¹⁷ (ugly), not *[krim:]

tagg [tak] (prong), not *[tak:]

kyss [çys] (kiss), not *[çys:]

All the forms above contain a short stressed vowel which is followed by a phonetic single consonant. According to the general principle about stressed rhymes in Norwegian, which states that every stressed rhyme necessarily has to branch, the short vowel in these forms clearly indicates that there is a coda consonant present in the syllabic structure. It is rather striking, however, that phonetically the word-final consonant in these forms is short. Such a structure is completely inadmissible in GP, which postulates that every coda require an onset as its governor. At this point a clear difference has to be made between phonetic reality (a term widely used in the literature) and phonological effects. In the discussed case the phonetic reality is clear: both the stressed vowel and the consonant that follows are short. Phonologically, however, we would like to postulate the so-called *virtual* or *abstract geminates* (see SÉGÉRAL and SCHEER 2001), i.e. structures which are not perceived phonetically, but which have a direct and important impact on phonological processes. As it seems, the presence of virtual geminates in the forms in (4) is determined by the presence of an empty nuclei in word-final position. Here is another set of examples:

(5) lande [lan:ə] (land)

mette [met:ə] (feed)

neppe [nep:ə] (hardly, scarcely)

kalle [kal:ə] (call)

verre [væ:r:ə] (worse)

komme [k^hɔm:ə] (come)

tagge [t^hak:ə] (serrate)

kysse [çys:ə] (kiss)

All these words are verbs in the infinitive form, which in Norwegian generally ends in a schwa. Here the difference between the forms in (4) and (5) manifests itself very clearly. An empty nucleus in (4) is not able to license a (phonetic) geminate, whereas in (5) we see that

¹⁷ In Norwegian, the *m* is never written double, when word-final.

the licensing abilities of the schwa are bigger; hence, a geminate appears (for a development of the idea of different licensing strength between empty nuclei and vowels with phonetic content consult CYRAN 2003).

Note at the same time that, as was said above, an empty nucleus in Norwegian is able to license a non-geminate coda-onset governing domain, i.e. a juncture of two different melodies, as the examples below demonstrate:

(6) kast [k^hast] (throw)

akt [akt] (act)

storm [stɔrm] (storm)

fisk [fisk] (fish)

The above observations allow us to formulate a conclusion called The Geminate Licensing Constraint, which is expressed as follows:

(7) The Geminate Licensing Constraint

In Norwegian, a phonetic geminate has to be licensed by the following full nucleus (= geminates are not licensed when followed by a consonant or when word-final, i.e. followed by an empty nucleus)

Note that our Geminate Licensing Constraint includes not only the context of an empty word-final nucleus, but also the situation where a geminate would be followed by a consonant. In the next sections we will provide examples where a geminate is simplified in contact with a consonant-initial past tense suffix. In both cases, giving the absence of a phonetically realised nucleus, the geminate will be not licensed and hence it will appear as a simplex consonant.

The above observation about the licensing strength of word-final empty nuclei and the constraint on geminate licensing in (7) have important consequences for our further discussion on the morphology of Norwegian verbs: verbs terminating in a coda-juncture which is a geminate (i.e. one melody) choose a different variant of the past tense suffix than

verbs that end in a coda-onset contact consisting of two different consonants, i.e. two different melodies.

10.1.2. Turning back to the past

Even more important than the difference between stem-final coda-onset relations and stem-final branching onsets (i.e. word-internal consonant clusters) is the fact, that all the forms in (2) terminate in a sequence of two different consonants, i.e. two different melodies. This is particularly striking in contrast with the examples in (1b), where there is a stem-final geminate, i.e. one melody doubly associated to two skeletal slots. As we have seen, the past tense differs for verbs that terminate in two different melodies from the ones that terminate in a geminate. When a sequence of two different consonants appears stem-finally, the past tense suffix appears as [ɛt], while [tɛ] attaches to verbs ending in a geminate. This implies a number of generalisations. First of all, it is noticeable that in the past tense stem-final sequences of two different consonants require a full vowel. The past tense of the verb *blinke* [plɪŋkə] (to blink) appears in the following shape:

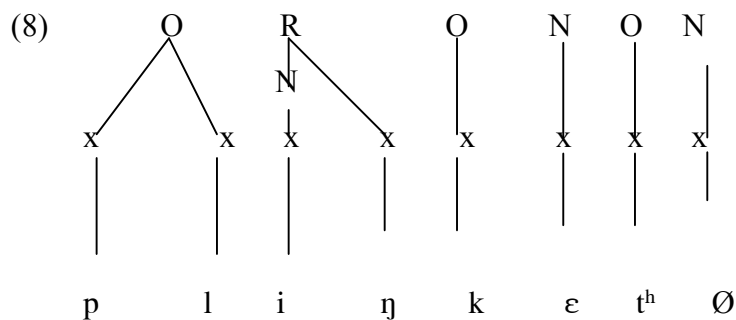

No nucleus appears when a geminate occurs stem-finally. We said before that only phonetically realised nuclei are able to license a geminate. When followed by an empty nucleus (i.e. word-finally, cf. (4)) or another consonant, a geminate is simplified to a phonetic single consonant. This is exactly what happens in forms like those in (9)¹⁸:

¹⁸ As can be seen, in Norwegian the spelling does not always show that we deal with a geminate, as in the case of [l:] or [n:], which in some cases can be graphically represented by *ld* and *nd* respectively. Naturally, the

(9) kall-e [kal:ə] (call)	kalt-e [kaltə]
dømm-e [tœm:ə] (judge)	døm-te [tœmtə]
kjenn-e [çɛn:ə] (know)	kjen-te [çɛntə]
strek-e [strɛk:ə] (stretch)	strek-te [strɛktə]
meld-e [mɛl:ə] (announce)	meld-te [mɛltə]
send-e [sɛn:ə] (send)	send-te [sɛntə]

The question is why verbs like those above do not choose the vowel-initial [ɛt]-variant of the suffix, in other words, why we do not find past tense forms like e.g. *[kal:ət], *[çɛn:ət] or *[strɛk:ət]. All the forms with an asterix are completely possible, yet non-existing in Modern Norwegian. The answer seems to lie in the nature of what we find stem-finally in verbs like those in (2) and those in (9). We decide to call the mechanism that governs this difference **The Melody Preservation Principle**. Norwegian, much the same as other Germanic languages, hardly tolerates sequences of three and more consonants (apart perhaps from sequences which result from compounding). A triconsonantal combination would constitute a serious complication for the syllabic structure, because a nucleus, a geminate and an onset would require four skeletal slots (not to mention governing relations which would have to be established in such a complicated domain. Deleting one of the consonants in (8) would result in losing a melodic material that was associated with the deleted skeletal slot. To prevent the melodic material from being lost, in (8) a nucleus appears between the stem-final consonant combination (is it a coda-onset juncture or a branching onset) and the past tense suffix. Hence, there is no need to simplify or suppress the skeletal build-up of the syllabic structure and, consequently, the melody of all the three consonants remains untouched. In (9) on the other hand a nucleus does not have to intervene, since a geminate (one melody, two timing slots) simplifies at the skeletal level in front of the past tense suffix, but without any loss of melody:

orthography reflects some historical changes only, which are irrelevant from the phonological point of view, but which the reader should be aware of.

With regard to the choice of the past tense suffix, verbs that end in a geminate behave exactly in the same way as verbs that terminate in a single postvocalic consonant. This is the second considerable group of verbs that choose the [tə]-shape of the past tense suffix. Consider the following examples:

- | | | |
|----------------------------------|--------------|---|
| (11) bak-e [pa:k ^h ə] | (to bake) | bak-te [bak ^h t ^h ə] |
| vrak-e [vra:k ^h ə] | (to discard) | vrak-te [vra:k ^h t ^h ə] |
| krev-e [krɛ:və] | (to demand) | krev-de [krɛv ^t tə] |
| lag-e [la:kə] | (to make) | lag-de [laktə] |
| vis-e [vi:sə] | (to show) | vis-te [vi:stə] |
| hør-e [hø:rə] | (to hear) | hør-te [hø:t ^h ə] |
| hyl-e [hy:lə] | (to scream) | hyl-te [hy:ltə] |

As can be seen from the above set of the examples, two things are involved in creating the past tense of the verbs above. First of all, it is the alternation in vowel length, and second, voicing (i.e. aspiration vs. lack of aspiration) pattern. As for the length of the vowel, a closer inspection of the data reveals two striking facts. First of all, all verbs that end in a sonorant in the infinitive have a long vowel in the past tense form as well:

- | | | |
|--------------------|-------------|-----------------|
| (12) hør-e [hø:rə] | (to hear) | hør-te [hø:tə] |
| hyl-e [hy:lə] | (to scream) | hyl-te [hy:ltə] |

If this were true for all the verbs in (11), we could conclude that the Norwegian past tense is created analytically (in the sense of KAYE 1995), i.e. the past tense suffix would create a phonological domain on its own, which would have no influence on the length of the vowel. This is, however, not the case and the domainhood of the past tense suffix must be rejected out of hand. Interestingly, the obstruent [s] displays exactly the same behaviour as sonorants, thus all verbs that end in [s] have a long vowel in the past tense. The phonological behaviour of [s], which in some cases patterns with sonorants, and in others - with obstruents, requires further analysis.

Thus, an invariable generalisation with regard to the length of the vowel in the past tense can only be reached for verbs terminating in a sonorant and [s]. In the remaining cases, i.e. when the stem-final consonant is a fricative or a plosive, no such watertight rule can be

formulated. A classical example of such variation is the pair *vrake* [vra:k^hə] - *vrakte* [vra:k^ht^hə] vs. *bake* [pa:k^hə] - *bakte* [pak^ht^hə]. Although, as we see, the stem-final consonant is the same for both verbs ([k^h]), the preterite form differs in that the former contains a long vowel (exactly as in the infinitive), while the latter has a short vowel (contrary to the infinitive form).¹⁹ The situation is quite different from what occurs in Modern Icelandic, a language closely related to Norwegian. As reported in detail by GUSSMANN (2002b) and described in more detail below, whenever a consonant cluster emerges in the preterite, the vowel is invariably short. The situation in Norwegian is definitely more complex. Since what is traditionally called “closed syllable shortening” only applies to some stems within a given morphological category in Norwegian (KRISTOFFERSEN 2000: 210), our aim is only to catch some general and predominant tendencies.

As we said above, the only regular pattern is the one in which all verbs with a stem-final sonorant have a long nucleus in the preterite form. As for the other stem-final consonants, there is some variation. The statistical presentation in KRISTOFFERSEN (2000: 210) can serve as a starting point.

Following the data presented in KRISTOFFERSEN (2000: 210) we see that length preservation in the past tense applies to majority of examples (87% percent of the body of data collected by KRISTOFFERSEN show a long vowel in the preterite). If so, one has to conclude that the general quantity rule established for Norwegian, which describes the structure of the stressed rhyme, cannot be applied automatically to morphologically complex forms. Let us now examine verbs ending in a sonorant or [s]. In the preceding sections we showed that a sonorant or [s] followed by a plosive is invariably assigned to the position of the rhymal complement, a structure which conforms to a typical well-formed coda-onset juncture, e.g. *salt* [sałt] (salt), *svamp* [svaɱp] (sponge), *vente* [vɛɳtə] (to wait), *kaste* [kʰastə] (to throw). Needless to say, the stressed nucleus is always short. In monomorphemic words a form like *[sa:lt] or *[vɛ:ntə] is hence completely ruled out. Contrary to this observation, in the past tense the nucleus is always long, although what follows could be a well-formed coda-onset as well, e.g. *hylte* [hy:ltə], *viste* [vi:stə]. Our immediate conclusion is that the sonorant

¹⁹ An important reservation needs to be made here. As is well-known, the theoretical framework adopted in this paper, namely Government Phonology, does not allow any form of resyllabification. Hence, the difference between the infinitive of the verb *bake* (with a long nucleus) and the preterite form of this verb (with a short vowel) cannot be explained in terms of vowel shortening or lengthening. It is rather the phonological principles that govern the structure of these forms and which are crucial for the analysis (cf. GUSSMANN 2002b: 199). Moreover, the preterite form cannot be seen as derived from the infinitive, since no form of phonological derivation is allowed. The infinitive form serves rather as an indicator than a basic form (GUSSMANN 2002b: 196).

and the plosive [t] of the past tense suffix obviously do not create a coda-onset juncture, i.e. they are not adjacent on the skeletal level. It is possible to assume that the sonorant and the plosive belong to two consecutive onsets, separated by an empty nucleus. Consider the following representation:

(13) a. *hyle* [hy:lə]

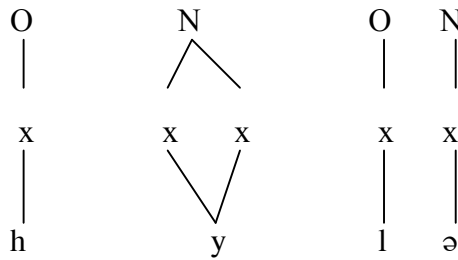

b. *hylte* [hy:l̥tə]

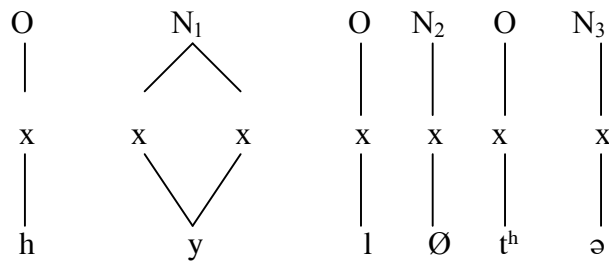

The presentation in (13a) illustrates the situation in the infinitive. The intervocalic sonorant belongs to the onset licensed by the final schwa. This is precisely what we could predict according to our theoretical assumptions. In agreement with the structure of the branching rhyme in Norwegian, the stressed nucleus is long and occupies two timing slots. On the other in (13b) we have a possible representation of the structure of the verb *hyle* in the past tense. As in the infinitive, the sonorant is assigned to an onset, and the preceding nucleus branches. The plosive [t^h] of the past tense suffix also occupies an onset. These two onsets are separated by a nucleus (N₂), which does not get any phonetic manifestation and which is properly governed by the final nucleus N₃. The fact that the nucleus N₁ branches, automatically signals that the form in question is morphologically complex (cf. SANDØY 1994: 238, see also VOGT 1942: 223 for the same conclusion cast in different terminology). Extending our discussion to consonants others than sonorants, we will arrive at similar observations. Again, in monomorphemic words a sequence as [kt] or [pt] is always syllabified

as a coda-onset juncture, e.g. *akt* [ak^ht^h] (act), *sakte* [sak^ht^hə] (slowly), *krypt* [kryp^ht^h] (crypt).²⁰ In the past tense, however, in most cases such sequence will be split up by an intervening empty nucleus:

- | | |
|---|--|
| (14) <i>søk-e</i> [sø:k ^h ə] (to search) | <i>søk-te</i> [sø:k ^h t ^h ə] |
| <i>måp-e</i> [mo:p ^h ə] (gape) | <i>måp-te</i> [mo:p ^h t ^h ə] |

Moreover, there is another complication concerning the past tense of the verbs which terminate in a single consonant. We have so far discussed verbs with a voiceless (= aspirated) stem-final consonant. There are, however, examples of verbs where the stem-final consonant is a non-aspirated obstruent, i.e. [t] or [k], e.g.

- | | |
|-------------------------------------|-------------------------|
| (15) <i>lad-e</i> [la:tə] (to load) | <i>lad-de</i> [lat:ə] |
| <i>gled-e</i> [kle:tə] (to please) | <i>gled-de</i> [klet:ə] |
| <i>lag-e</i> [la:kə] (to make) | <i>lag-de</i> [laktə] |

Two things should be emphasized here. First of all, it is easy to observe that the suffix of the past tense appears in a shape slightly different from the one that we have presented so far, namely the plosive is now non-aspirated, or, as the tradition wants it, voiced. As is well-known, in analyses of phonetic and phonological systems of the Scandinavian languages, one prefers to talk about the contrast between aspirated and unaspirated plosives rather than that of voiced and voiceless. In other words, it is the presence or the absence of aspiration which distinguishes the series of plosives represented graphically by *p, t, k* and *b, d, g*. The former set of consonants is aspirated, while the latter is unaspirated. In the phonological model adopted in this paper it is the high tone element (**H**) which is responsible for the aspiration contrast in Germanic languages (cf. HARRIS 1994: 133ff). Hence, a voiceless plosive contains the high tone element in its melodic make-up while a voiced plosive lacks this element.

There arises a question now whether the high tone element is or is not a part of the melodic structure of the suffix. It seems that in the case of verbs ending in a non-aspirated

²⁰ In Norwegian, the governing relations [kt] and [pt] cannot be reversed; in other words the [k] or the [p] in the onset can never govern the [t] in the coda. It clearly shows that the consonants in question are not of equal complexity. As it seems, the [t] is more complex than the [k] and presumably equal to the [p]. The melodic make-up of these consonants could be expressed as follows: [k] {ʔ·H·h·_}, [p] {ʔ·H·h·U·_} and [t] {ʔ·H·h·A·_}.

obstruent or a glide, the suffix-initial consonant lacks the high tone element and is realised as the unaspirated dental plosive [t]. When the stem-final consonant is tone-bearing, the high tone element in the suffix-initial consonant is present, giving [t^h]. To assume that we deal with two separate and independent suffixes is highly unfavourable, since, as we saw before, the distribution of the aspirated and unaspirated suffix-initial consonant in the past tense is perfectly predictable and strictly ruled by the context. Instead, an alternative analysis can be put forward, in which the tone-bearing suffix-initial [t^h] loses its high tone element in contact with the preceding toneless consonant.

The uniformity in voicing of the stem-final consonant and the suffix-initial consonant is completely unsurprising and follows from a general rule in Norwegian, which disallows postvocalic sequences of obstruents which do not agree in voicing (KRISTOFFERSEN 2000: 57). Hence, one finds forms as *heft* [hɛft^h] and *hevd* [hɛvɔ], whereas a form like *[hɛft] is completely impossible. Exceptions such as *Vidkun* [vɪtkʉn] (proper name) or *vodka* [vɔtkɑ] (vodka) must be seen as marginal, among other things because an alternative pronunciation with an aspirated plosive is allowed (cf. KRISTOFFERSEN 2000: 75). The aspiration agreement between the stem-final consonant and the suffix-initial consonant can be seen as another argument against the domainhood of the preterite suffix. If the preterite suffix was a domain on its own, it could be assumed that the suffix-initial consonant are invisible to the final consonant of the verb stem (consult again KAYE 1995). Since the two consonants in question are visible to each other (as the aspiration agreement clearly illustrates), there can be no possibility for any domain boundaries. What is more interesting and has to be our next important observation is the fact that the forms presented in (15) all contain a short vowel in the preterite form. For a verb like *lade* [la:tə] (to load) it is a natural consequence of the gemination, which emerges when a consonant-initial past tense suffix is added to the stem of the verb (as is well-known, the Obligatory Contour Principle disallows two identical segments to be adjacent on the melodic level (cf. KENSTOWICZ 1994: 322ff)).²¹ It is interesting to note that the non-aspirated stem-final obstruent appears in the onset in the infinitive, but in the coda in the past tense form. Although different from what we observed with other stem-final consonants, the pattern for the non-aspirated obstruents [k] and [t] is regular, i.e. the vowel in the preterite is always short. It should be noted here that the situation is quite different from what one finds in a sister language of Norwegian, namely in Icelandic. As laid out in all

²¹ Note that the same happens when the stem ends in the voiceless coronal stop [t^h]. By adding the past tense suffix (which has an aspirated consonant as well), a geminate emerges, hence the vowel of the stem is short. For an explanation of this process against the theoretical background of the moraic theory of syllabic weight consult KRISTOFFERSEN 2000: 214f).

phonetics and phonological studies on Modern Icelandic (cf. EIRÍKUR RÖGNVALDSSON 1990: 54ff, 1993: 65f, INDRÍÐI GÍSLASON and HÖSKULDUR ÞRÁINSSON 1993: 78ff, see also GUSSMANN 2002a: 134ff), obstruent sequences are not admitted in Modern Icelandic. Briefly speaking, an aspirated plosive cannot appear as a coda. Hence, if a plosive follows in the onset, the preceding plosive emerges as a fricative, which can be governed then by the plosive in the onset due to the difference in the complexity between the two consonants (a plosive is more complex than a fricative, so it can act as a governor in a coda-onset juncture). Obviously no such lenition of plosives in the coda takes place in Norwegian. As it seems, Modern Norwegian operates with governing relations, which are non-present in e.g. Modern Icelandic. This accidental situation follows a few more general rules that govern the phonological systems of the two languages – we will discuss this matter in one of the sections below.

We omitted here one more voiced consonant, namely the phonologically ambiguous labio-dental [v]. The reason for this omittance is that in Norwegian the [v] behaves like an obstruent in some cases, but as a sonorant in others.²² Without going into details, which would be irrelevant here (for a detailed discussion see KRISTOFFERSEN 2000: 39), we have to say that with respect to the length of the stressed nucleus in the past tense, the Norwegian labio-dental patterns with the voiced obstruents [t] and [k] in that it chooses the voiced variant of the preterite suffix. However, unlike in the case of [t] and [k], the nucleus which precedes the labio-dental is long in the majority of cases.

The last and probably the most confusing group of verbs which we will discuss in connection with the length of the stressed nucleus in the preterite is the group of verbs which are monosyllabic in the infinitive and end in a long nucleus (in such a case the stem is identical to the verb as a whole). This issue will be discussed in the following section.

Consider the following set of examples (from KRISTOFFERSEN 2000: 212):

(16) ro [ru:] (row)	ru-dde [rut:ə] (preterite)	ru-dd [rut] (past part.)
spa [spa:] (spade)	spa-dde [spat:ə]	spa-dd[spat]
flå [flo:] (fly)	flå-dde [flot:ə]	flo-dd [flot]
sy [sy:] (sew)	sy-dde [syt:ə]	sy-dd [syt]

²² In this respect, the phonological behaviour of the Norwegian labio-dental [v] is similar to the corresponding consonant in Russian and partly also in Polish, as discussed at length by ANDERSEN (1969) and GUSSMANN (2002a: 193ff).

As one can notice, both in the past tense and in the past participle, the vowel is invariably and consistently short. The past tense suffix appears here as a non-aspirated geminate.²³ In such a case, if the vowel was long, we would be dealing with a structure which is completely impossible in Modern Norwegian, namely with a long nucleus followed by a long consonant, i.e. hypothetically [ru:tə] or [spa:tə]. As we showed in the preceding section, such a syllabic structure (i.e. super-heavy rhymes) is no more existing in standard Norwegian (although it was perfectly possible at the older stages in the history of the language and is still present in some archaic dialects of Norwegian). Hence, to conform to the well-formed structure of syllabic organisation, the stressed vowel before a geminate appears as short.

This particular situation is explained by KRISTOFFERSEN (2000: 212f) by means of the rule of Vowel Shortening, which applies in derived environments where a sequence of a stressed long vowel + an obstruent is created by any word formation rule that adds an obstruent-initial suffix. After the vowel has been shortened, the free mora will associate to the following suffix consonant (hence the gemination of the consonant). Another proposal of a rule can be found in HOVDHAUGEN (1971: 176), whereas the author assumes that the gemination of the suffix consonant takes place as first, and then the nucleus of the verb shortens. In Government Phonology, which is, as is well-known, a non-derivational theory, no such rules can be accepted, since no stages/levels of derivation are allowed. It is, in my opinion, irrelevant whether the nucleus shortens as first and then allows the free mora to associate with the suffix consonant, or whether both “processes” take place at the same time. What is crucial is the fact that this particular group of verbs choose exactly this variant of the past tense suffix and that this causes changes in the syllabic structure of the verb and the suffix, conforming automatically to the structure of the syllable (the rhyme in particular) that Modern Norwegian recognises and allows, namely that a geminate can only follow a short vowel. If this condition is met, no rules or tricky mechanisms such as mora delinking are needed.

Before discussing this peculiar group of verbs we will give some helpful examples from another inflectional category of Norwegian morphology, i.e. from the neuter form of adjectives. Consider the following examples:

²³ The historical development of this group verbs in Norwegian is rather unclear (cf. SEIP 1931: 326). Both Swedish and Norwegian got the preterite suffix –dde, while Icelandic retained the old form –ði (e.g. *ná – náði* and others, cf. GUSSMANN 2002b: 196f). Diachronically, it is possible to assume that in Norwegian, unlike in Icelandic, the dental spirant [ð] was susceptible to get lost at some stage, but it was needed as a marker of the preterite, so it was replaced by the dental plosive [d] (SEIP 1931: 195).

- (17) blå [plɔ:] (blue) – blått [plɔtʰ]
 grå [krɔ:] (grey) – grått [krɔtʰ]
 fri [fri:] (free) – fritt [fritʰ]
 bred [pre:] (broad) – bredt [pre:tʰ]

From the point of view of their syllabic structure, the adjectives above clearly remind us of the verbs in (16): they end in a stressed vowel and create their neuter form with help of a geminated suffix *-tt* (we leave aside the difference in aspiration between the past tense suffix and the neuter suffix). The fact seems not to be accidental and calls for an explanation. A possible solution is to assume that what we get in reality, as far as the suffixes are concerned, is precisely a geminate with the structure as follows:

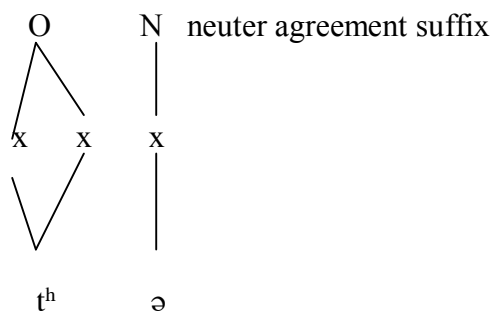
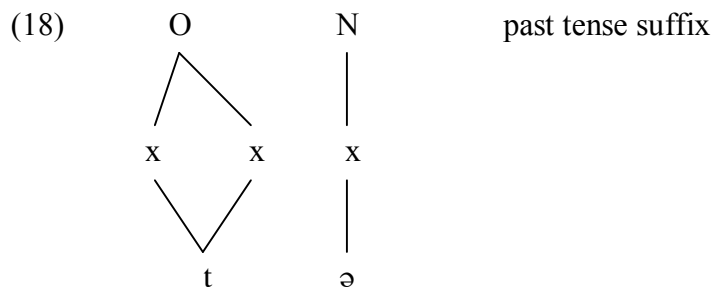

If such a structure is adopted as the basis for the analysis of both past tense and neuter agreement in Norwegian, the most difficult group of verbs and adjectives (16) and (17) becomes paradoxically the easiest one to account for. If the suffix begins with an empty nucleus followed by a geminate, the stem-final vowel, which in the infinitive occupied two available skeletal slots, now occupies only one skeletal slot of the stem, the second one being assigned to the initial consonant of the suffix. This remains in total agreement with the

structure of the stressed rhyme in Norwegian, where a geminate can only follow a short vowel.

We will now try to revise what was said so far about the creating of the past in verbs ending in a consonant cluster or a single postvocalic consonant. If we assume that the suffix is a phonological geminate, also those verbs will conform to our analysis. For verbs ending in a single postvocalic consonant, an addition of the geminate-initial past tense suffix would create a structure which is normally not attested in the language, namely that a consonant would be followed by a geminate. In such a case a typical mechanism is to simplify the geminate. The effect that follows is that the suffix is pronounced as a single consonant. The stem- and domain-final empty nucleus (N_2 in our representation in (13)) has enough strength and ability to license the single, stem-final consonant, hence it can remain unpronounced. The difference between these verbs and verbs that terminate in a consonant cluster is that the domain-final nucleus is realised as a full vowel, whereas the suffix-final vowel remains unpronounced. This difference can be explained by the means of our Melody Preservation Principle, that we formulated above.

10.2. Past tense in Icelandic – similarities and differences

At first glance the past tense suffix in Icelandic behaves in a similar fashion to the correspondent suffix in Norwegian. On the surface, the Icelandic suffix has three surface variants transcribed as [t, ɖ, ð]. Their distribution is determined by the stem-final environment of the verb. Before we formulate the conditions on the distribution of the particular suffix variants, we would like to pay some attention to the phonetic manifestation of the suffix.

As is well-known, in Icelandic there is no difference between voiced and voiceless plosives. The difference between, say, *p* and *b* is not the voicelessness of the former and voicing of the latter, but rather the presence and the absence of aspiration in the two consonants respectively. In our terms it will be more appropriate to work with elements rather than the notion of aspiration and associate the contrast between e.g. *p* and *b*, *t* and *d* and *k* and *g* with the high tone element **H** in the melodic make-up of the historically voiceless plosives.²⁴ Consequently, historically voiced plosives will lack the element **H** in their melodic

²⁴ In GP it is generally assumed that it is precisely the high tone element **H** that is responsible for source distinctions (see HARRIS 1994: 133ff). The element theory is perhaps the subtheory of GP that has been subject

composition. Hence, turning back to our main topic, i.e. to the dental suffix in Icelandic, its appearance in three surface forms can only be accounted for in phonological terms. Phonetically there are actually only two shapes the suffix can appear in: [t] (spelt as *t* or *d*) and [ð]. Although phonetically the same, the former suffix can have different phonological effects, depending on the presence or absence of the high tone element **H**. If the suffix contains the high tone element, adding it to a verb stem ending in a sonorant results in the devoicing of the sonorant. No such process occurs when the suffix lacks the element **H** in the melodic make-up. Consider the following examples which illustrate this important difference:

- (19) a. *nenna* [nɛn:a] (to feel like) *nennti* [nɛnti] (pret.)
 villa [vitla] (to lead astray) *vilti* [vɪlti] (pret.)
- b. *kenna* [cɛn:a] (to teach) *kenndi* [cɛnti] (pret.)
 fella [fɛtla] (fell) *felldi* [fɛlti] (pret.)

In (19a) we find examples of verbs which choose the tone-bearing suffix of the past tense. Clearly, since no sonorant devoicing takes place in the forms in (19b), the conclusion has to be that the chosen past tense suffix in these forms lacks the tone specification (the suffix-initial consonant is necessarily toneless). Further modifications, like e.g. the simplification of the stem-final geminate, will be discussed later on. It should be stressed here that a fundamental phonological distinction has to be made between the tone-bearing and toneless dental suffix. While the former contains the element **H** (taking the phonological form [t^h]), the latter does not ([t]). Note also that the third phonological variant of the suffix is the spirantal one, [ð]. Our next concern will be the distribution of these suffix variants, seen in a broader context of a number of phonological regularities that govern the system of Icelandic.

As rightly pointed out in GUSSMANN (2002b: 195ff), traditional descriptions of the distribution of the past tense suffix that one can find in textbooks and grammars of Icelandic (see e.g. KRESS 1982: 48ff, STEFÁN EINARSSON 1967: 82f) give little help for a phonological analysis, as is always the case with a largely insignificant list of rules. Hence, instead of listing such rules, we propose rather a comprehensive analysis of the distribution of the past tense suffix according to more general tendencies of the selection of a particular variant. Now our concern will be the effects the past tense suffix can have on the base of the verb it is attached to.

of the greatest modifications. For an early account on elements consult HARRIS and LINDSAY (1995),; for a radical break with this early view see e.g. PÖCHTRAGER (2006).

We will start the discussion with the least problematic variant of the suffix, namely the spirantal [ð]. Consider first the following examples of verbs (from GUSSMANN 2000b: 196) that choose the spirantal variant of the past tense suffix, grouped according to the stem-final environment:

(20) a. long stressed vowel

ná [nau:] (to reach)	náði [nau:ði] (pret.)
spá [spau:] (to prophecy)	spáði [spau:ði] (pret.)

b. the sonorant trill

heyra [hei:ra] (to hear)	heyrði [heirði] (pret.)
læra [lai:ra] (to learn)	lærði [lairði] (pret.)

c. voiced non-coronal fricatives

leyfa [lei:va] (to allow)	leyfði [leivði] (pret.)
horfa [hørva] (to look)	horfði [hørvði] (pret.)
segja [sei:ja] (to say)	sagði [saɣði] (pret.)
byggja [pɪʃ:a] (to build)	byggði [pɪɣði] (pret.)

The examples in (20c), which are most complex, involve some interesting modifications of the verb stem, an issue which we will return to later on. For the time being we will observe a very important property of some of the forms given above. As one can easily notice, in some cases the long vowel of the infinitive appears as short in the preterite form. Precisely this property makes the Icelandic past tense different from the Norwegian one. In Norwegian in most of the cases where the verb terminates in a single consonant, there are no shortening of the stressed vowel. In Icelandic, on the other hand, a short vowel in the preterite form is a general rule. Interestingly, this is in complete agreement with a more general tendency in Icelandic concerning the structure of the stressed rhyme. In brief, a stressed rhyme necessarily branches, either in the form of a long nucleus or a short, simplex nucleus followed by a coda consonant, which is further licensed by the following onset head. Hence, for every verb that terminates in a single consonant, the addition of the past tense suffix automatically results in the shortening of the stressed vowel (e.g. (20b)). Additionally, there is a set of verbs that end in two consonants (e.g. *horfa*). In any such case, there is an automatic suppression of the second of the consonants, apart from a very over-studied styles of speech, where it can be pronounced (GUSSMANN 2002b: 197). In short, the dental suffix can be preceded by only one

consonant, with which it creates a coda-onset governing domain. Whenever a cluster of two consonants occurs, usually the second member is getting suppressed, hence conforming to the typical structure of a stressed rhyme. The above formulation may be presented graphically:

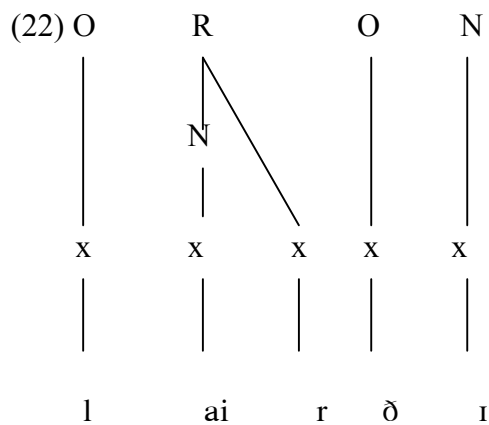
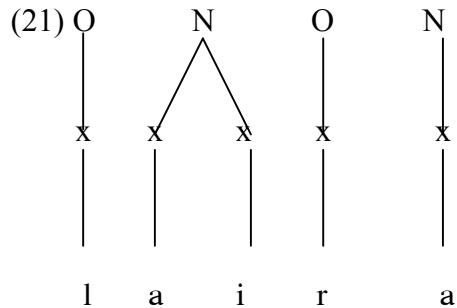

Both (21) and (22) demonstrate the typical stressed rhyme in Icelandic, differing, however, in the number of postvocalic consonants and hence the length of the stressed nucleus. In (21) we find an infinitive form with one postvocalic timing slot associated with consonantal melodic material. Following our analysis we assign this consonantal melody to the onset which is licensed directly by the following nucleus and which leaves the preceding syllable open. As a result, we get a long vowel that occupies both skeletal slots available in a branching rhyme.

(22) on the other hand presents the same verb, but in the preterite form. Here the difference is the following: the addition of the dental suffix creates a well-formed coda-onset juncture. Such a structure necessarily implies that the preceding nucleus is short (the coda consonant occupies one of the two skeletal slots of the branching rhyme, hence there is only one slot left that is available for the vocalic material). The suffix-initial spirant [ð] acts a head of the governing domain, the trill as a dependent.

Our next step is to analyse the second variant of the past tense dental suffix, namely the one which is spelled *d* and which, as we remember, is a toneless plosive. Below we supply the examples in (19b) with a number of additional verb forms (consult again GUSSMANN 2000b: 201):

- (23) reyna [rei:na] (to try) reyndi [reintɪ] (pret.)
 dæma [tai:ma] (to judge) dæmdi [taimɪ] (pret.)
 hvíla [k^hvi:la] (to rest) hvíldi [k^hviltɪ] (pret.)
 dimma [tɪm:a] (to darken) dimmdi [tɪmtɪ] (pret.)

First, let us observe the regularity that we already know from some of the examples in (20). A single postvocalic consonant in the infinitive is associated with an onset, hence the preceding vowel can branch. In the past tense, when in contact with the dental suffix, the stem-final consonant assigns to the position of the coda, closing the syllable and leaving only one timing slot for the nucleus, which cannot branch in result. Again, the dental suffix can follow at last one consonant in order to conform to the structure of the Icelandic branching rhyme (note that in the last example the geminate [m:] simplifies to a simplex [m] in the preterite). Since this is completely unsurprising and known from our analysis above, we can leave this issue without any further discussion. What needs to be clarified is the very choice of the toneless plosive in this particular context. A closer inspection of the facts explains that when the stem-final consonant is a sonorant stop, the suffix is also a stop. Obviously, a trill is easier to be governed in the coda position; hence, a fricative of the suffix is sufficient to act as a governor. But when the verb terminates in a sonorant stop, there is a need for a stronger, i.e. more complex domain head; hence, the plosive suffix is chosen. Conclusions that can be drawn from what was said above are the following: the choice between the spirantal and the plosive suffix is made on the basis of the stem-final environment of the verb. Less complex verb-final consonants are easier to be satisfied, so the spirantal suffix is sufficient to conform to the Complexity Condition (as formulated in HARRIS 1994: 167ff) and create a well-formed coda-onset governing domain. Since sonorant stops are more complex than the monoelemental trill or the voiced spirants, they require a more complex onset head; thus the plosive suffix is chosen.

There arises a question what happens when the stem of the verb terminates in a non-geminate consonant cluster? This issue we would like to examine now is definitely more complex than the situation sketched above and includes a number of theoretical implications.

As usual, here are some data that will serve as a point of departure for our proceeding discussion:

(24) nefna [nɛpna] (to name)	nefndi [nɛmtɪ] (pret.)
demba [tɛmpa] (to shower)	dembdi [tɛmtɪ] (pret.)
rigna [rɪkna] (to rain)	rigndi [rɪŋtɪ] (pret.)
sigla [sɪkla] (to sail)	sigldi [sɪtɪ] (pret.)

The forms above do not exhaust the possibilities of verb-final consonant clusters; they only serve here as an illustration of the problem. As one immediately notices, there is a difference between the infinitive and the preterite form in that in the latter the skeletal position of the second member of the verb-final cluster has been lost. In case no such simplification takes place, we would be left with a sequence of three consonants, a structure which is not allowed and tolerated in Icelandic. Note here that the simplification of the second consonant in verb-final clusters is slightly different from what we find in Norwegian. Recall that in (3) we formulated **the Melody Preservation Principle**, according to which no melody can get lost in the course of past tense creation in Norwegian. If the verb ends in a consonant cluster, Norwegian chooses a vowel-initial suffix in order to retain all melodic and skeletal material from the stem-final environment. GUSSMANN (2002b: 205) argues against using the term suppression or deletion in the case of Icelandic and proposes to use the term *merger* instead. An argument for such a decision is that apart from the melody simplification also a modification of the verbal base takes place. This has been summarized in GUSSMANN (2002b: 205):

(25) [pn], [mp] > [m]
[kn], [nʃ] > [ŋ]
[kl], [lʃ] > [tʃ]

We are now able to clarify what the process in (24) consists in. To protect the syllabic structure from an intolerable sequence of three consonants, the timing slot of the second consonant of the verbal stem is removed. What happens to the melody is that it is accommodated into the associated sonorant (consult GUSSMANN 2002b: 205). In this sense Icelandic operates with some kind of melody preservation, but unlike in Norwegian, the melody does not receive a separate skeletal slot to be associated with.

To summarise what we know about the toneless plosive we can say that it is only the element theory that allows us to identify a common feature of verb-final consonants that choose this particular suffix. Basing on articulatory properties only, we would get a rather odd class of unaspirated plosives and stop sonorants, something which would be hardly satisfying from a phonological point of view. But an inspection of the elemental make-up of these two consonant groups reveals their common characteristics: they are all toneless stops, i.e. they are lacking the element **H**, but contain the stopness (occlusion) element **ʔ**. The class can be therefore described as a class of toneless stops, including both obstruents and sonorants.

The suffix which remains is the tonebearing dental suffix [t^h] which, as we remember, is characterised by the presence of the high tone element **H** generally manifested by aspiration. Nevertheless, aspiration is not the only phonetic (and presumably phonological) effect which has its source in the presence of **H**. The other two include sonorant devoicing and preaspiration. As a result, the tonebearing dental suffix never appears as aspirated. On the basis of we can consider some examples:

- (26) a. *mæla* [mai:la] (to speak) *mælti* [maiłtɪ] (pret.)
 b. *breyta* [prei:t^ha] (to change) *breytti* [preihtɪ] (pret.)

In (26a) there appears a stop sonorant-final verb that chooses the toned dental suffix in the past tense. Regularly, the stop sonorant occupies the onset in the infinitive and the coda when in contact with the onset dental plosive. However, additional modifications occur. Although the suffix dental plosive contains the aspiration element **H**, phonetically it appears as unaspirated, being pronounced exactly in the same way as its toneless counterpart in e.g. (24). But the effects the tonebearing suffix imposes on the base-final sonorant are clear and cannot be found in the context of the toneless suffix. In (26a) the sonorant is realized as devoiced, whereas a homophonous verb *mæla* (with the reading “measure”) which chooses the toneless suffix has a voiced sonorant, *mældi* [mailtɪ].²⁵ The devoicing of the sonorant is a result of the transmission of the high tone element **H** from the dental plosive to the preceding sonorant. As a result, the plosive appears as unaspirated, while the sonorant - as voiceless.

²⁵ The question arises why one of the verbs chooses the toneless and the other the toned variant of the suffix. If we assume that a sonorant stop can be governed by both toned and toneless plosive and that a general tendency of Icelandic phonology is to select the weakest variant that conforms to governing principles (GUSSMANN 2002b: 202), we have to conclude that [mailtɪ] is the regular form, whereas [maiłtɪ] is irregular and lexically determined.

In (26b), on the other hand, we find a verb that terminates in a single toned plosive. The effect that arises after attaching the dental toned suffix to the verbal base is preaspiration, occurring among other things to eliminate aspirated geminates. The emergence of preaspiration clearly indicates that the element **H** is contained both in the base-final consonant and in the dental plosive. In the preterite **H** is transmitted to position of the coda and realised as [h].

Here are some more examples of verbs that choose the toned variant of the past tense suffix:

- (27) a. fylkja [fɪl̥ca] (dress up) fylkti [fɪɰtɪ] (pret.)
 b. gapa [ka:p^ha] (gape) gapti [kaftɪ] (pret.)
 c. vaka [va:k^ha] (be awake) vakti [vaxtɪ] (pret.)
 d. sleppa [slehpa] (to let go) sleppti [sleftɪ]

The first example in the set above illustrates something that we already know from our previous analysis. The two base-final consonants and the dental plosive of the suffix would create an inadmissible combination of three consonants. In order to prevent such sequence from occurring, a familiar mechanism is being applied: the skeletal position of the second member of the base-final cluster is being removed, while the melody that was associated to it merges with the melody of the preceding sonorant. Transferring the high tone element **H** from the suffix plosive to the preceding sonorant results in the devoicing of the latter.

Examples (27 b-d) introduce a certain new mechanism, which we have not observed yet, i.e. the difference between the stem-final consonant of the infinitive and the coda consonant in the preterite form. While in the infinitive there occurs a toned plosive, in the preterite we find its spirantal congener, i.e. a plosive which lacks the stopness element **ʔ**. Again, this mechanism is not a lone wolf of Icelandic phonology, but rather a very strictly followed rule which disallows domain-internal sequence of plosives. Spirantisation of the coda plosive functions as a lenition mechanism and controls the correct governing relation between the onset head and the coda dependent which has to be of less complexity than its governor.

The last set of examples includes verbs ending in a dental. Consider the forms below:

- (28) skemmta [sçɛmta] (amuse) skemmti [sçɛmtɪ] (pret.)
 vænta [vain̥ta] (to expect) vænti [vain̥tɪ] (pret.)
 lenda [lɛnta] (end up) lenti [lɛntɪ] (pret.)

Although we encounter dental-final verbs for the first time, some striking similarities with what we have said so far can be found in the examples above. Actually, the examples in (28) introduce nothing new, since they employ mechanisms that we are already familiar with: a base-final plosive preceded by a sonorant and followed by the suffix plosive would yield an intolerable sequence of three consonants. In the first two examples both the base-final and suffix plosive are aspirated. The geminate they create has to be degeminated in order to conform to the structure of the stressed rhyme. In the third example the potential sequence [ntt^h] is realized as a voiceless sonorant followed by a plosive. Also here, the devoicing of the sonorant is not surprising, as the high tone element of the suffix plosive is transferred to the preceding sonorant.

In the above pages we tried to give a possibly comprehensive phonological description of past tense creation in Norwegian and Icelandic with side-glances to Norwegian neuter agreement suffix of adjectives. In both languages the dental suffix appears in a number of different shapes, the selection of which is strictly determined by the stem-final environment. Apparently, each of the languages in question chooses a slightly different mechanism. In Norwegian the phonological shape of the suffix does not reflect its phonetic value. What really is of importance is a geminate-initial suffix, as can be seen in examples of the type *ro – rodde*. In Icelandic, the suffix is single-consonant-initial and the form of the suffix dental has (or at least can have) important consequences for the shape of the verbal base (recall vowel shortening, sonorant devoicing, preaspiration, melody merger, simplification on the skeletal level). More generally, despite the sometimes fundamental differences between the Norwegian and Icelandic past tense, they are always created according to the general principles of the working phonological system of the language. In this sense an analysis of the phonology of the past tense can lead to very instructive and interesting conclusions concerning the phonological systems of Norwegian and Icelandic as a whole.

References

- ALLWOOD, Jens, Bo RALPH, Paula ANDERSON, Dora KÓS-DIENES and Åsa WENGELIN (eds.) (1994): *Proceedings of the XIVth Scandinavian Conference of Linguistics and the VIIIth Conference of Nordic and General Linguistics August 16-21 1991*. (= *Gothenburg Papers in Theoretical Linguistics 69*), Volume 1.
- ANDERSEN, Henning (1969): The phonological status of the Russian ‘labial fricatives’. *Journal of Linguistics* 5, pp. 121-127.
- ARCHANGELI, Diana and Douglas PULLEYBLANK (1994): *Grounded Phonology*. (= *Current Studies in Linguistics 25*). Cambridge, MA: MIT Press.
- ARONOFF, Mark (1998): Isomorphism and monotonicity: or the disease model of morphology. In: LAPOINTE et al. (eds.), pp. 411-418.
- AWEDYKOWA, Sława (1972): *Konfrontative Studien zu phonetisch-phonologischen Strukturen der polnischen und norwegischen Sprache*. Poznań: Wydawnictwo Naukowe UAM.
- AWEDYKOWA, Sława (1975): Versuch einer konfrontativen Darstellung der Silbenstruktur der polnischen und norwegischen Sprache. *Studia Germanica Posnaniensia IV*, pp. 81-87, reprinted in: JAHR (ed.) (1997), pp. 112-118.
- ÁSTA SVAVARSDÓTTIR (1984): Samfelld eða ekki samfelld? Um vensl hljómda í íslensku og þáttagildi /l/. *Íslenskt mál og almenn málfræði* 6, pp. 7-32.
- BALDUR RAGNARSSON (1973): *Íslensk hljóðfræði*. Reykjavík: Iðunn.
- BENUA, Laura (2000): *Phonological relations between words*. New York and London: Garland Publishing.
- BERULFSEN, Bjarne (1967): *Norsk grammatikk. Ordklassene*. Oslo: Aschehoug.
- BERULFSEN, Bjarne (1969): *Norsk uttaleordbok*. Oslo: H. Aschehoug & Co. (W. Nygaard).
- BJORVAND, Harald, Even HOVDHAUGEN and Hanne GRAM SIMONSEN (eds.) (1984): *Språkvitenskap. En elementær innføring*. Oslo – Bergen – Tromsø: Universitetsforlaget.
- BJÖRN GUÐFINSSON (1946): *Mállýzkur I*. Reykjavík: Ísafoldaprentsmiðja.
- BLOCH-ROZMEJ, Anna (2008): *Melody in Government Phonology*. Lublin: Wydawnictwo KUL.
- BOBROWSKI, Ireneusz, Krystyna KOWALIK (eds.) (2006): *Od fonemu do tekstu. Prace dedykowane Profesorowi Romanowi Laskowskiemu*. Kraków: Wydawnictwo Lexis.

- BORGSTRØM, Carl Hjalmar (1938): Zur Phonologie der norwegischen Schriftsprache nach der ost-norwegischen Aussprache. In: *Norsk Tidsskrift for Sprogvidenskap IX*, pp. 250-273, reprinted in: JAHR & LORENTZ (eds.) 1981), pp. 170-186.
- BORGSTRØM, Carl Hjalmar (1947): De prosodiske elementer i norsk. In: JAHR and LORENTZ (eds.) (1983), pp. 137-143.
- BOTMA, Bert (2001): A licensing account of aspiration in Modern Icelandic. In: HUME, E. et al. (eds.), pp. 53-76.
- BROCKHAUS, Wiebke (1995): *Final devoicing in the phonology of German*. (= *Linguistische Arbeiten 336*). Tübingen: Niemeyer.
- CHAPMAN, Kenneth G. (1962): *Icelandic-Norwegian linguistic relationships*. (= *Norsk Tidsskrift For Sprogvidenskap. Supplement bind VII*). Oslo: Universitetsforlaget.
- CHARETTE, Monik (1991): *Conditions on phonological government*. (= *Cambridge Studies in Linguistics 58*). Cambridge: Cambridge University Press.
- CHOMSKY, Noam (1965): *Aspects of the theory of syntax*. Cambridge: The MIT Press.
- CHOMSKY, Noam and Morris HALLE (1968): *The sound pattern of English*. New York: Harper and Row.
- COATES, Richard (1987): Icelandic quantity and syllabification. *Phonologica 1984*, pp. 33-38.
- CRUICKSHANK, Hege (2000): *Styringsfonologisk analyse av kvantitetsendringer i nordnorsk. En oppgave i historisk fonologi*. Unpublished M.A. thesis, University of Bergen.
- CYGAN, Jan (1971): *Aspects of English syllable structure*. Wrocław: Zakład Narodowy im. Ossolińskich.
- CYRAN, Eugeniusz (1997): *Resonance elements in phonology: a study in Munster Irish*. (= *PASE Studies and Monographs 3*). Lublin: Wydawnictwo Folium.
- CYRAN, Eugeniusz (ed.) (1998): *Structure and interpretation: studies in phonology*. Lublin: Folium.
- CYRAN, Eugeniusz (2003a): Branching onsets in Polish. In: PLOCH (ed.), pp. 303-320.
- CYRAN, Eugeniusz (2003b): *Complexity scales and licensing strength in phonology*. Lublin: Wydawnictwo KUL.
- DRESSLER, Wolfgang Ulrich, Hans C. LUSCHÜTZKY, Oskar E. PFEIFFER and John R. RENNISON (eds.) (1992): *Phonologica 1988*. Cambridge: Cambridge University Press.
- DURAND, Jacques and Francis KATAMBA (eds.) (1995): *Frontiers of phonology. Atoms, structures and derivations*. London and New York: Longman.

- DZIUBALSKA-KOŁACZYK, Katarzyna (1995): *Phonology without the syllable. A study in the natural framework*. Poznań: Motiwex.
- DZIUBALSKA-KOŁACZYK, Katarzyna (ed.) (2001): *Constraints and preferences*. (= *Trends in linguistics. Studies and monographs 134*). Berlin-New York: Mouton de Gruyter.
- DZIUBALSKA-KOŁACZYK, Katarzyna (2002): *Beats-and-Binding phonology*. Frankfurt: Peter Lang.
- DZIUBALSKA-KOŁACZYK, Katarzyna (2012): Modern Natural Phonology and phonetics. In: CYRAN, Eugeniusz, Henryk KARDELA and Bogdan SZYMANEK (eds.): *Sound, Structure and Sense. Studies in Memory of Edmund Gussmann*, pp. 199-210. Lublin: Wydawnictwo KUL.
- EIRÍKUR RÖGNVALDSSON (1990a): *Íslensk hljóðfræði handa framhaldsskólum*. Reykjavík: Mál og menning.
- EIRÍKUR RÖGNVALDSSON (1990b): *Íslensk orðhlutafræði. Kennslukver handa nemendum á háskólastigi*. Reykjavík: Málvísindastofnun Háskola Íslands.
- EIRÍKUR RÖGNVALDSSON (1993): *Íslensk hljóðkerfisfræði*. Reykjavík: Málvísindastofnun Háskola Íslands.
- EIRÍKUR RÖGNVALDSSON (⁴2002): *Íslensk hljóðfræði. Kennslukver handa nemendum á háskólastigi*. Reykjavík: Málvísindastofnun Háskola Íslands.
- ELERT, Claes-Christian, Iréne JOHANSSON and Eva STRANGERT (eds.) (1984): *Nordic prosody III. Papers from a symposium*. University of Umeå.
- ELIASON, Stig (1985): Stress alternations and vowel-length: new evidence for an underlying nine-vowel system in Swedish. *Nordic Journal of Linguistics* 8, pp. 101-129
- ELIASON, Stig (1986): Sandhi in Peninsular Scandinavian. In: ANDERSEN, Henning (ed.) (1986): *Sandhi phenomena in the languages of Europe*. (= *Trends in linguistics. Studies and monographs 33*), pp.271-300. Berlin-New York-Amsterdam: Mouton de Gruyter.
- ENDRESEN, Rolf Theil (1974): On retroflex segments in Norwegian. *Norsk Tidsskrift for Sprogvidenskap* 28, pp. 73-78. Reprinted in: JAHR and LORENTZ (eds.) (1981), pp. 287-292.
- ENDRESEN, Rolf Theil (1984): Fonologi. In: BJORVAND et al. (eds.), pp. 45-86.
- FAARLUND, Jan Terje, Svein LIE, Kjell Ivar VANNEBO (1997): *Norsk referansegrammatikk*. Oslo: Universitetsforlaget.
- FINTOFT, Knut (1961): The duration of some Norwegian speech sounds. *Phonetica* 7, pp. 19-39. Reprinted in: JAHR and LORENTZ (eds.) (1983), pp. 220-240

- FISIAK, Jacek (2002): *In memory of Professor Margaret Schlauch (1898 – 1986)*. (= *Studia Anglica Posnaniensia* 38). Poznań: Wydawnictwo Naukowe UAM.
- FOLEY, James (1977): *Foundations of phonological theory*. Cambridge: Cambridge University Press.
- FRETHEIM, Thorstein (1969): Norwegian stress and quantity reconsidered. *Norsk Tidsskrift for Sprogvidenskap* 23, pp. 76-96. Reprinted in: JAHR and LORENTZ (eds.) (1983), pp. 315-334.
- FRETHEIM, Thorstein (1974): The Norwegian retroflex flap and the concept of 'natural class' in phonology. *Norsk Tidsskrift for Sprogvidenskap* 28, pp. 79-84. Reprinted in: JAHR and LORENTZ (eds.) (1981), pp. 293-299.
- FUDGE, Eric C. 1969. Syllables. *Journal of Linguistics* 3, pp. 253–286.
- GARNES, Sara (1976): *Quantity in Icelandic: production and perception*. (= *Hamburger Phonetische Beiträge Band 18*). Helmut Buske Verlag.
- GIBB, L. (1992): *Domains in Phonology: with evidence from Icelandic, Finnish and Kikuyu*. Unpublished PhD dissertation, University of Edinburgh.
- GIBSON, Courtenay St. John (1997): *Icelandic phonology in Optimality Theory*. Ph.D. thesis, University of Iowa.
- GUÐRÚN KVARAN, GUNNLAUGUR INGÓLFSSON and SVAVAR SIGMUNDSSON (eds.) (1981): *Afmælikveðja til Halldórs Haldórssonar*, pp. 110-123. Reykjavík: Íslenska málfræðifélagið.
- GUÐRÚN THÓRHALLSDÓTTIR (ed.) (2000): *The Nordic languages and modern linguistics 10. Proceedings of the Tenth International Conference of Nordic and General Linguistics, University of Iceland June 6-8, 1998*. Reykjavík: Institute of Linguistics, University of Iceland.
- GUSSMANN, Edmund (1982): Review of KRISTJÁN ÁRNASON (1980a). *Íslenskt mál og almenn málfræði* 4, pp. 303-316.
- GUSSMANN, Edmund (1985): The morphology of a phonological rule: Icelandic vowel length. In: GUSSMANN (ed.), pp. 75-94.
- GUSSMANN, Edmund (ed.) (1985): *Phono-morphology. Studies in the interaction of phonology and morphology*. Lublin: Redakcja Wydawnictw Katolickiego Uniwersytetu Lubelskiego.
- GUSSMANN, Edmund (1999): Preaspiration in Icelandic: unity in diversity. *Anglica Wratislaviensia* 35, pp. 163-181.

- GUSSMANN, Edmund (2000): Icelandic preaspiration as a testing ground for phonological theories. In: GUÐRÚN THÓRHALLSDÓTTIR (ed.), pp. 93-103.
- GUSSMANN, Edmund (2001a): Hidden identity, or the double life of segments. In: DZIUBALSKA-KOŁACZYK (ed.), pp. 229-249.
- GUSSMANN, Edmund (2001b): Icelandic vowel quantity: issues of theory and description. *Scripta Neophilologica Posnaniensia III*, pp. 69-79.
- GUSSMANN, Edmund (2002a): *Phonology. Analysis and theory*. Cambridge: Cambridge University Press.
- GUSSMANN, Edmund (2002b): The dental suffix in Modern Icelandic: phonology, morpho(phono)logy, and the lexicon. In: FISIĄK (ed.), pp. 191-214.
- GUSSMANN, Edmund (2003): Are there branching onsets in Modern Icelandic? In: PŁOCH (ed.), pp. 321-337.
- GUSSMANN, Edmund (2004a): Polish front vowels or Badouin de Courtenay *redivivus*. *Studies in Polish Linguistics 1*, pp. 103-130.
- GUSSMANN, Edmund (2004b): The irrelevance of phonetics: The Polish palatalisation of velars. *Corpus 3*, pp. 125-152.
- GUSSMANN, Edmund (2006a): *Icelandic and universal Phonology*. (*Bruno-Kress-Vorlesung 2005. Greifswalder Universitätsreden, Neue Folge, Nr. 122*). Greifswald.
- GUSSMANN, Edmund (2006b): Roman Laskowski and the development of Polish (morpho)phonology. In: BOBROWSKI, Ireneusz, Krystyna KOWALIK (eds.), pp. 21-39.
- GUSSMANN, Edmund (2006c): Icelandic vowel length and governing relations in phonology. *Lingua Posnaniensis XLVIII*, pp. 21-41.
- GUSSMANN, Edmund and Eugeniusz CYRAN (1998): Polish consonantal sequences: a phonological testing ground. In: CYRAN (ed.), pp. 127-138.
- GUSSMANN, Edmund and John HARRIS (2002): Word-Final Onsets. *University College London Working Papers in Linguistics 14*, pp. 53-94.
- GÅRDING, E., G. BRUCE and R. BANNERT (eds.) (1978): *Nordic Prosody*. Lund: Department of Linguistics.
- HAGSTRÖM, Björn (1970): Supradentaler i färöiskan. Ett bidrag till beskrivningen av färöiskt uttal. *Fróðskaparrit 18*. Reprinted in: THOMSEN (ed.), pp. 67-80.
- HAMANN, Silke (2003a): *The phonetics and phonology of retroflexes*. LOT Netherlands Graduate School of Linguistics. Utrecht: The Netherlands.
- HAMANN, Silke (2003b): Norwegian retroflexion – licensing by cue or prosody?

Nordlyd 31, pp. 63-77.

Handbook of the International Phonetic Association (1999)

HARRIS, John (1990): Segmental complexity and phonological government. *Phonology* 7, pp. 255-300.

HARRIS, John (1994): *English sound structure*. Oxford & Cambridge: Blackwell.

HARRIS, John (1997): Licensing Inheritance: an integrated theory of neutralisation. *Phonology* 14, pp. 315-370.

HARRIS, John and Edmund GUSSMANN (1998): Final codas: why the west was wrong. In: CYRAN (ed.), pp. 139-162.

HARRIS, John and Geoff LINDSEY (1995): The elements of phonological representation. In: DURAND and KATAMBA (eds.), pp. 34-79.

HASLEV, Marianne (1984): Vowel length in unaccented syllables in Norwegian. In: ELERT et al. (eds.), pp. 101-105.

HAUGEN, Einar (1942): On the stressed vowel systems of Norwegian. In: *Studies by Einar Haugen*. The Hague – Paris, pp. 102-114. Reprinted in: JAHR and LORENTZ (eds.) (1981), pp. 196-207

HAUGEN, Einar (1958): The phonemics of Modern Icelandic. *Language* 34, pp. 55-88.

HERMANS, Ben (1984): The relation between aspiration and preaspiration in Icelandic. In: HULST and SMITH (eds.), pp. 237-265.

HOVDHAUGEN, Even (1971): *Transformasjonell generativ grammatikk. Annen utgave med øvelser*. Oslo-Bergen-Tromsø: Universitetsforlaget.

HOVDHAUGEN, Even (ed.) (1980): *The Nordic languages and modern linguistics 4*. Oslo-Bergen-Tromsø: Universitetsforlaget.

HREINN BENEDIKTSSON (1963): The non-uniqueness of phonemic solutions: quantity and stress in Icelandic. *Phonetica* 10, pp. 133-153.

HREINN BENEDIKTSSON (ed.) (1970): *The Nordic languages and modern linguistics*. Reykjavík: Vísindafélag Íslendinga.

HULST, Harry van der and Norval SMITH (eds.) (1984): *Advances in nonlinear phonology*. Foris Publications.

HUME, E., E. SMITH and J. VAN DER WEIJER (eds.) (2001): *Surface syllable structure and segment sequencing*. Leiden: Academic Press

HÖSKULDUR THRÁINSSON (1978): On the phonology of Icelandic preaspiration. *Nordic Journal of Linguistics* 1, pp. 3-54.

- HÖSKULDUR THRÁINSSON (1980): Sonorant devoicing at Lake Mývatn. In: HOVDHAUGEN (ed.), pp. 355-364.
- HÖSKULDUR Thráinsson (1981): Stuðlar, höfuðstaðir, hljóðkerfi. In: GUÐRÚN KVARAN et al. (eds.), pp. 110-123.
- HÖSKULDUR THRÁINSSON, HJALMAR P. PETERSEN, JÓGVAN Í LON JACOBSEN and ZAKARIS SVABO HANSEN (2004): *Faroese. An overview and reference grammar*. Tórshavn: Føroya Fróðskaparfelag.
- INDRIÐI GÍSLASON and HÖSKULDUR ÞRÁINSSON (1993): *Handbók um íslenskan framburð*. Rannsóknarstofnun Kennaraháskóla Íslands.
- IVERSON, Gregory K, Joseph C. SALMONS (1995): Aspiration and laryngeal representation in Germanic. *Phonology* 12, pp. 369-396.
- Íslensk orðabók*. MÖRÐUR ÁRNASON (eds.) (2003), Reykjavík: Edda.
- JAHR, Ernst Hákon (ed.) (1997): *Eastern European contributions to Scandinavian linguistics*. (= *Studia Nordica* 2). Oslo: Novus Forlag.
- JAHR, Ernst Hákon and Ove LORENTZ (eds.) (1981): *Fonologi / Phonology*. Oslo: Novus Forlag.
- JAHR, Ernst Hákon and Ove LORENTZ (eds.) (1983): *Prosodi / Prosody*. Oslo: Novus Forlag.
- JENSEN, Sean (1994): Is ? an element? Towards a non-segmental phonology. *SOAS Working Papers in Linguistics and Phonetics* 4, pp. 71-78.
- JÓHANNES G. JÓNSSON (1994): The feature [asp] in Icelandic phonology. *Studia Linguistica* 48 (1), pp. 28-45.
- JÓN Ófeigsson (1920-1924): Træk af moderne islandsk Lydlære. In: SIGFÚS BLÖNDAL (ed.), pp. XIV-XXVII.
- KARDELA, Henryk and Bogdan SZYMANEK (eds.) (1996): *A Festschrift for Edmund Gussmann from his friends and colleagues*. Lublin: Redakcja Wydawnictw Katolickiego Uniwersytetu Lubelskiego.
- KAYE, Jonathan (1990): Coda licensing. *Phonology* 7.2, pp. 301-330.
- KAYE, Jonathan (1995): Derivations and interfaces. In: DURAND and KATAMBA (eds.), pp. 289-332.
- KAYE, Jonathan (1996): Do you believe in magic? The story of s+C sequences. In: KARDELA and SZYMANEK (eds.), pp. 155-176.
- KAYE, Jonathan (ms.): *A user's guide to government phonology*. University of Ulster.

- KAYE, Jonathan, Jean LOWENSTAMM and Jean-Roger VERGNAUD (1985): The internal structure of phonological elements: a theory of charm and government. *Phonology Yearbook* 2, pp. 305-328.
- KAYE, Jonathan, Jean LOWENSTAMM and Jean-Roger VERGNAUD (1989): Konstituentenstruktur und Rektion in der Phonologie. *Linguistische Berichte, Sonderheft 2*, pp. 30-75.
- KAYE, Jonathan, Jean LOWENSTAMM and Jean-Roger VERGNAUD (1990): Constituent structure and government in phonology. *Phonology* 7, pp. 193-231.
- KEER, Edward (2000): Icelandic preaspiration and the moraic theory of geminates. In: GUÐRÚN THÓRHALLSDÓTTIR (ed.), pp. 145-154.
- KEHREIN, Wolfgang and Richard WIESE (eds.) (1998): *Phonology and morphology of the Germanic languages*. (= *Linguistische Arbeiten* 386). Tübingen: Max Niemeyer Verlag.
- KENSTOWICZ, Michael (1994): *Phonology in generative grammar*. Oxford: Blackwell.
- KIPARSKY, Paul (1984): On the lexical phonology of Icelandic. In: ELERT et al. (eds.), pp. 135-164.
- KIRKEBY, W. A. (1986): *Norsk-engelsk ordbok. Stor utgave*. Kunnskapsforlaget.
- KLOSTER JENSEN, Martin (1961): Long consonant after a short vowel. *Proceedings of the Fourth International Congress of Phonetic Sciences*, pp. 678-681. Reprinted in: JAHR and LORENTZ (eds.) (1983), pp. 241-244.
- KOLSRUD, Sigurd (1950): *Norsk ljoðkskrift*. Oslo: I Kommissjon hos Jacob Dybwad.
- KRESS, Bruno (1982): *Isländische Grammatik*. Leipzig: VEB Verlag Enzyklopädie.
- KRISTJÁN ÁRNASON (1977): Preaspiration in Modern Icelandic: phonetics and phonology. In: *Sjötíu ritgerðir helgaðar Jakobi Benediktssyni*, pp. 495-504. Reykjavík: Stofnun Árna Magnússonar.
- KRISTJÁN ÁRNASON (1978): Quantity, stress and the syllable in Icelandic: formal vs. functional arguments. In: GÁRDING et al. (eds.), pp. 137-142.
- KRISTJÁN ÁRNASON (1980a): *Quantity in historical phonology. Icelandic and related cases*. Cambridge: Cambridge University Press.
- KRISTJÁN ÁRNASON (1980b): *Íslensk málfræði. Seinni hluti*. Reykjavík: Iðunn.
- KRISTJÁN ÁRNASON (1984): Toward a model of Modern Icelandic syllable types. *Íslenskt mál og almenn málfræði* 6, pp. 135-153.
- KRISTJÁN ÁRNASON (1986): The segmental and suprasegmental status of preaspiration in Modern Icelandic. *Nordic Journal of Linguistics* 9, pp. 1-23.

- KRISTJÁN ÁRNASON (1992): Problems in the Lexical Phonology of Icelandic. In: DRESSLER et al. (eds.), pp. 5-14.
- KRISTJÁN ÁRNASON (1998): Vowel shortness in Icelandic. In: KEHREIN and WIESE (eds.), pp. 3-25.
- KRISTJÁN ÁRNASON (2005): *Hljóð. Handbók um hljóðfræði og hljóðkerfisfræði.* (= *Íslensk tunga. I. bindi.*). Reykjavík: Almenna Bókafélagið.
- KRISTOFFERSEN, Gjert (1982): Om progressiv stemhetsassimilasjon i norsk. *Maal og minne*, pp.167-184.
- KRISTOFFERSEN, Gjert (1994): The Nordic quantity shift and the question of extrametricality. In: ALLWOOD et al. (eds.): pp. 219-231.
- KRISTOFFERSEN, Gjert (2000): To err or not to err: litt om retroflekering i norsk scenespråk. In: Øivin ANDERSEN, Kjersti FLØTTUM and Torodd KINN (eds.): *Menneske, språk og fellesskap: festskrift til Kirsti Koch Christensen på 60-årsdagen 1. desember 2000.* Oslo: Novus.
- KRISTOFFERSEN, Gjert (2000): *The Phonology of Norwegian.* Oxford: Oxford University Press.
- KUSMENKO, Ju. K. (2003): Die Supradentale. Eine nordskandinavisch-indoarisch-drauidische Parallele. In: *Материалы международной конференции, посвященной 100-летию со дня рождения профессора Михаила Ивановича Стеблин-Каменского 10-12 сентября, Санкт-Петербург*, pp. 185-195. Наука.
- LADEFOGED, Peter (2006): *A course in phonetics.* Thomson Wadsworth.
- LADEFOGED, Peter and Ian MADDIESON (1996): *The sounds of the world's languages.* Oxford: Blackwell Publishers.
- LAHIRI, Aditi (2000): Hierarchical restructuring in the creation of verbal morphology in Bengali and Germanic: evidence from phonology. In: LAHIRI (ed.), pp. 71-123.
- LAHIRI, Aditi (ed.) (2000): *Analogy, levelling, markedness.* (= *Trends in Linguistics. Studies and Monographs 127*). Berlin – New York: Mouton de Gruyter.
- LAPOINTE, Steven G., Diane K. BRENTARI and Patrick M. FARELL (eds.) (1998): *Morphology and its relation to phonology and syntax.* Stanford, California: CSLI Publication.
- LASS, Roger (1984): *Phonology. An introduction to basic concepts.* Cambridge: Cambridge University Press
- LEHISTE, Ilse (1970): *Suprasegmentals.* The MIT Press.
- LIBERMAN, Anatoly (1982): *Germanic accentology. Volume 1. The Scandinavian languages.* Minneapolis: University of Minnesota Press.

- LODGE, Ken (2007): Timing, segmental status and aspiration in Icelandic. *Transactions of Philological Society* 105:1, pp. 66-104
- LORENTZ, Ove (1996): Length and correspondence in Scandinavian. *Nordlyd* 24, pp. 111-128.
- MAGNÚS PÉTURSSON (1976): *Drög að almennri og íslenskri hljóðfræði*. (= *Ritröð Kennaraháskóla Íslands og Iðunnar I*). Reykjavík: Iðunn.
- MAGNÚS PÉTURSSON (1978): *Drög að hljóðkerfisfræði*. (= *Ritröð Kennaraháskóla Íslands og Iðunnar III*). Reykjavík: Iðunn.
- MALONE, Kemp (1953): Long and short in Icelandic phonemics. *Language* 29, pp. 61-62.
- MIKKELSEN, L. and C. POTTS (eds.) (2002): *WCCFL 21 Proceedings*. Sommerville, MA: Cascadilla Press.
- MORÉN, Bruce (2001): *Distinctiveness, coercion and sonority. A unified theory of weight*. New York and London: Routledge.
- MORÉN, Bruce and Viola MIGLIO (2000): Issues in Icelandic phonology: a unified approach. In: GUÐRÚN THÓRHALLSDÓTTIR (ed.), pp. 155-167.
- MURRAY, R. and Theo VENNEMANN (1983): Sound change and syllable structure in Germanic phonology. *Language* 59, pp. 514-528.
- PÉTUR HELGASON (1993): *On coarticulation and connected speech processes in Icelandic*. Reykjavík: Málvísindastofnun Háskóla Íslands.
- PÉTUR HELGASON (2002): *Preaspiration in the Nordic languages. Synchronic and diachronic aspects*. PhD dissertation, Stockholm University, Department of Linguistics.
- PIND, Jörgen (2000): The perception of quantity in Icelandic. In: GUÐRÚN THÓRHALLSDÓTTIR (ed.), pp. 135-144.
- PLOCH, Stefan (1999): *Nasals on my mind. The phonetic and the cognitive approach to the phonology of nasality*. Ph.D. thesis, Department of Linguistics, School of Oriental and African Studies, University of London.
- PLOCH, Stefan (ed.) (2003): *Living on the edge. 28 papers in honour of Jonathan Kaye*. (= *Studies in Generative Grammar* 62). Mouton de Gruyter.
- POPPERWELL, R. G. (1963): *The Pronunciation of Norwegian*. Cambridge University Press.
- PÖCHTRAGER, Markus Alexander (2006): *The structure of length*. PhD thesis, University of Vienna.
- REISS, Charles (1994): *A theory of assimilation with special reference to Old Icelandic phonology*. Unpublished PhD dissertation, Harvard University.

- REISS, Charles (1997): The origin of the nn/ð alternation in Old Icelandic. *Nowele Vol. 30*, pp. 135-158.
- RINGEN, Catherine O. (1999): Aspiration, preaspiration, deaspiration, sonorant devoicing and spirantization in Icelandic. *Nordic Journal of Linguistics 22*, pp. 137-156.
- RINNAN, Gyda Dahm (1969): Nok en gang om alveolarene. In: *Tilegnet Carl Hj. Borgstrøm. Et festskrift på 60-årsdagen 12.10.69 fra hans elever*, pp. 128-133. Oslo-Bergen-Tromsø. Reprinted in JAHR and LORENTZ (eds.) (1981), pp. 273-277.
- RØNHOVD, Jarle (1993): *Norsk morfologi*. Ad Notam Gyldendal AS.
- SANDØY, Helge (1994): The nature of „overlong syllables” in the Scandinavian languages. In: DRESSLER et al.(eds.), pp. 233-242.
- SCALISE, Sergio (1986): *Generative morphology*. (= *Studies in generative grammar 18*). Foris Publications.
- SCHEER, Tobias (1998a): Governing domains are head-final. In: CYRAN (ed.), pp. 261-285.
- SCHEER, Tobias (1998b): A unified model of proper government. *The Linguistic Review 15*, pp. 41-67.
- SCHEER, Tobias (2004): *A lateral theory of phonology: what is CVCV, and why should it be?* Berlin: Mouton de Gruyter.
- SÉGÉRAL, Phillippe, Tobias SCHEER (2001): Abstractness in phonology: the case of virtual geminates. In: DZIUBALSKA-KOŁACZYK (ed.), pp. 311-337.
- SEIP, Didrik Arup (1931): *Norsk språkhistorie til omkring 1370*. Oslo: Aschehoug.
- SELKIRK, Elisabeth O. 1982. *The syllable*. Vol. 2, pp. 337-385. Dordrecht: Foris.
- SELMER, Ernst W. (1952): *Norsk lydskrift. En historisk-kritisk oversikt*. (= *Opuscula Phonetica Fasc. XIV*). Oslo: A. W. Brøggers Boktrykkeri A/S.
- SIGFÚS BLÖNDAL (ed.) (1920-1924): *Íslensk-dönsk orðabók*. Reykjavík: Verslun Þórarins B. Þorlákssonar.
- SIVERTSEN, Eva (1967): *Fonologi. Fonetikk of fonemikk for språkstudenter*. Oslo: Universitetsforlaget.
- STEBLIN-KAMENSKIJ, Michail (1965): Om alveolarer og kakuminaler i norsk og svensk. *Norsk Tidsskrift for Sprogvidenskap 20*, pp. 18-27. Reprinted in: JAHR and LORENTZ (eds.) (1981), pp. 249-258.
- STEFÁN EINARSSON (1927): *Beiträge zur Phonetik der isländischen Sprache*. Oslo: A.W. Brøggers Boktrykkeri A/S.
- STEFÁN EINARSSON (1949): *Icelandic: grammar, texts, glossary*. Baltimore: John Hopkins Press.

- SVEINN BERGSVEINSSON (1941): *Grundfragen der isländischen Satzphonetik*. Copenhagen: Munksgaard.
- STRANDSKOGEN, Åse-Berit (1979): *Norsk fonetikk for utlendinger*. Gyldendal Norsk Forlag.
- THOMSEN, Emil (ed.) (1991): *Átta greinir um føroyskt mál. Útgivnar til Björn Hagströms 70-ára føðingardag tann 20. januar 1991*. Tórshavn.
- TORVIK, Arne (1979): *Norsklære*. Universitetsforlaget.
- TRAVIS, Bradley G. (2002): Gestural timing and derived environment effects in Norwegian clusters. In: MIKKELSEN and POTTS (eds.), pp. 101-114.
- TRNKA, Bohumil (1997): Norwegian alveolar consonants. In: JAHR (ed.), pp. 108-111.
- VANVIK, Arne (1969): Norwegian prosody. *Norsk Tidsskrift for Sprogvidenskap* 23, pp. 71-75. Reprinted in: JAHR and LORENTZ (eds.) (1983), pp. 310-314.
- VANVIK, Arne (1972): A phonetic-phonemic analysis of Standard Eastern Norwegian. Part I. *Norsk Tidsskrift for Sprogvidenskap* 26, pp. 119-164.
- VANVIK, Arne (1985): *Norsk uttaleordbok. A Norwegian pronouncing dictionary*. Oslo: Fonetisk institutt, Universitetet i Oslo.
- VENNEMANN, Theo (1972): On the theory of syllabic phonology. *Linguistische Berichte* 18, pp. 1-18.
- VOGT, Hans (1942): The structure of Norwegian monosyllables. *Norsk Tidsskrift for Sprogvidenskap* 12, pp. 5-29. Reprinted in: JAHR and LORENTZ (eds.) (1981), pp. 208-231.
- WEIJER, Jeroen van der and Tetsuo NISHIHARA (eds.) (2001): *Issues in Japanese phonology and morphology*. (= *Studies in generative grammar* 51). Berlin - New York: Mouton de Gruyter.
- WEINSTOCK, John M. (1970): A sketch of Norwegian phonology. In: HREINN Benediktsson (ed.), pp. 572-598
- WERESZCZYNSKI, Aleksander (2005): *Þrjú ný líkön fyrir kerfi íslenskra lokhljóða*. Paper presented at the 19th Rasmus Rask Conference, 22.01.2005, Reykjavík.

STRESZCZENIE

Tematem niniejszej rozprawy jest analiza fonologiczna iloczasu w języku islandzkim i norweskim. Podstawę teoretyczną analizy stanowi model Fonologii Rządu.

W rozdziale pierwszym przedstawione zostały inwentarze dźwięków języka islandzkiego i języka norweskiego. Podkreślono jednocześnie, że stanowią one jedynie punkt wyjścia do dalszych analiz, ze względu na niezwykle ograniczoną rolę fonetyki w przyjętym modelu. W tym samym rozdziale opisano również hierarchię elementów prozodycznych (tj. akcentu, iloczasu i tonu) i wpływ akcentu (w tym akcentu emfaticznego) na dystrybucję długich i krótkich samogłosek.

Rozdział drugi przedstawia podstawowe założenia Fonologii Rządu. Ponieważ literatura ujęta w modelu Fonologii Rządu lub opisująca go jest względnie bogata, prezentację ograniczono wyłącznie do tych elementów, które mają bezpośrednie zastosowanie do opisu iloczasu. Wyjaśniono zatem pojęcia takie, jak rząd, licencjonowanie, puste elementy oraz konstytuty sylaby. Zwrócono również uwagę na tzw. Elementy, czyli podstawowe jednostki budowy segmentów fonologicznych.

Rozdział trzeci poświęcony jest tzw. wzdłużeniu w otwartych sylabach. Jak pokazała analiza danych językowych, potrzebna jest nowa, alternatywna definicja otwartej sylaby, która byłaby w stanie objąć swym zasięgiem wszystkie przykłady długich samogłosek, także te, które dotychczas ujmowane były jako nieregularne. Mowa tu o określonych zbitkach spółgłoskowych, które pozornie wbrew podstawowej regule poprzedza długa samogłoska.

W rozdziale czwartym szczegółowej analizie poddano zbitki spółgłoskowe, które występują na początku i wewnątrz wyrazów. Dla opisu iloczasu szczególnie istotna jest druga z wymienionych pozycji. Mimo że ogólna zasada iloczasu w języku islandzkim i języku norweskim głosi, że zbitkę spółgłoskową może poprzedzać wyłącznie krótka samogłoska, w obu językach znaleźć można liczne przykłady, które temu przeczą. W oparciu o analizę GUSSMANNA (GUSSMANN 2003) dla języka islandzkiego, szczegółowemu opisowi poddane zostały zbitki spółgłoskowe języka norweskiego. Na podstawie uniwersalnych, a także typowych dla języka norweskiego ograniczeń, zbitki spółgłoskowe podzielone zostały na te, które tworzą prawdziwe rozgałęzione nagłosy sylaby (ang. *true branching onsets*) i te, które nimi nie są. Dzięki przyjęciu założenia, że nagłos sylaby może występować również w środku słowa, nieregularne dotychczas formy wpisały się w definicję otwartej sylaby. Dla

podkreślenia uniwersalności tej definicji, przywołano dla porównania dane z języka farerskiego.

W rozdziale czwartym wprowadza się także pojęcie preaspiracji i współdzielenia elementu zwartości (ang. *stopness sharing*) oraz ich związek z iloczasem samogłosek.

Rozdział piąty w całości proponuje analizę preaspiracji w języku islandzkim. Preaspiracja opisana jest zarówno pod względem struktury melodycznej, jak i pozycji w obrębie sylaby. Pokazano, że preaspiracja, realizowana jako pełny segment [h], poprzedzona być może wyłącznie przez krótką samogłoskę. Dla kontrastu przywołano w przypisie preaspirację w języku farerskim, w którym nie jest ona realizowana jako pełny segment i w związku z tym może następować po długiej samogłosce.

Rozdział szósty poświęcony jest analizie spółgłosek retrofleksyjnych w języku norweskim. Analizie poddano zarówno budowę melodyczną tych spółgłosek, jak i ich pozycję w strukturze sylaby. Zaproponowano, by traktować spółgłoski retrofleksyjne jako geminaty fonologiczne (opis strukturalny) i jako połączenie (ang. *merge*) dwóch melodii (opis melodyczny).

Rozdział siódmy rozwija opis zbitek spółgłoskowych wewnątrz słowa, skupiając się jednak na takich, które zgodnie z ogólną regułą następują tylko po krótkiej samogłosce. Wyróżniono wśród nich tzw. wirtualne geminaty, jako zbitki spółgłoskowe licencjonowane przez samogłoskę niemą fonetycznie (tj. pusty ośrodek sylaby). Szczegółowej analizie poddano sekwencje spółgłoskowe języka islandzkiego, w których kolejność elementów może być odwrócona (ang. *reversible governing relations*). Jak wykazała analiza, określone restrykcje fonotaktyczne są wynikiem wewnętrznej budowy melodycznej spółgłosek i wywierają bezpośredni wpływ na iloczyn poprzedzającej samogłoski.

Rozdział ósmy prezentuje szczegółową analizę jednej spółgłoski islandzkiej, /s/, i jej znaczenia dla opisu iloczasu w tym języku. Jak wykazała analiza, /s/ w niektórych sytuacjach zachowuje się tak, jak spółgłoski właściwe, a w innych jak sonorant. Korzystając z terminologii GUSSMANNA (2001a), opisano /s/ jako „podwójnego agenta” w fonologii języka islandzkiego. Wyjątkowe zachowanie /s/ przejawia się w dwojakim przypisaniu do struktury sylaby. W pewnych sytuacjach /s/ pełni funkcję spółgłoski rządzącej (ang. *governor*), zachowując się tym samym jak spółgłoska właściwa, a w innych funkcję spółgłoski rządzonej (ang. *governee*), czyli sonorantu. Podwójna natura /s/ pociąga za sobą konsekwencje dla systemu fonologicznego języka islandzkiego. Mowa tu o spirantyzacji spółgłosek zwartowybuchowych, opisanych w rozdziale 8.2.

Rozdział dziewiąty ma za zadanie skonfrontowanie ustalonej w toku analizy reguły iloczasu dla języka islandzkiego i norweskiego z formami złożonymi morfologicznie, tj. derywatami i złożeniami. Teoretyczne założenie przyjętego modelu jest takie, że zasada iloczasu powinna być niezależna od informacji wykraczających poza fonologię, a więc również od informacji morfologicznych. Jak wykazała analiza, język norweski wykazuje w tym względzie znacznie więcej nieregularności niż język islandzki. W przypadku języka islandzkiego decydującym wydaje się być wyłącznie kontekst fonologiczny, podczas gdy w języku norweskim formy morfologicznie złożone wykazują wiele nieregularności i odstępstw od ogólnej reguły iloczasu.

W rozdziale tym ponownie zwrócono szczególną uwagę na zachowanie się /s/ w języku islandzkim.

Rozdział dziesiąty kontynuuje dyskusję nad rolą informacji morfologicznej w analizie iloczasu. Zaproponowano szczegółowy opis wybranej kategorii morfologicznej w języku norweskim i islandzkim, tj. tworzenia czasu przeszłego.

Jak dotąd żaden z dostępnych opisów nie był w stanie uporządkować reguł tworzenia czasu przeszłego prostego preteritum, który, zwłaszcza w odniesieniu do języka norweskiego, nastroczał ogromnych trudności nie tylko w teorii, ale także w praktyce dydaktycznej. Jak się wydaje, możliwa jest alternatywna analiza sufiksu czasu przeszłego, uwzględniająca, przynajmniej w pewnej mierze, czytelny kontekst fonologiczny, decydujący o wyborze konkretnego wariantu sufiksu czasu przeszłego. Przyjęcie uniwersalnej struktury tego sufiksu dla wszystkich klas czasowników pozwala ujednoczyć opis tworzenia preteritum oraz znacząco zmniejszyć liczbę nieregularności. Podobnie jak w rozdziale 9, analiza danych języka islandzkiego pokazała nieporównywalnie większą rolę kontekstu fonologicznego niż w przypadku języka norweskiego.