

Making the Cultural Landscape: Neolithic and Bronze Age Communities on Polish Lowland and their Environment

Janusz Czebreszuk & Marzena Szmyt, Poznań

Introduction

When we explore the meaning of the title, we face the question what relationships between human communities and their environment to define. Most often scholars speak of human impact as a factor that changes the primeval natural environment. But we would like to use a more complex definition of human impact that consists of at least four aspects: perception, use, transformation (change) and creation. People first perceive the natural environment and identify its resources. Then they use the environment and natural resources and

change or transform its elements, but also create some new components of the environment. Using and changing the primeval natural environment, people create as well a new quality marked by a landscape that is no longer natural but rather cultural instead, in which we have grown up, too.

While discussing such questions, our reference area will be the Polish Lowland that is a part of the Central European Plain. For our study we have chosen a western part of the Lowland: an area between the Vistula, Odra and Noteć rivers and the line

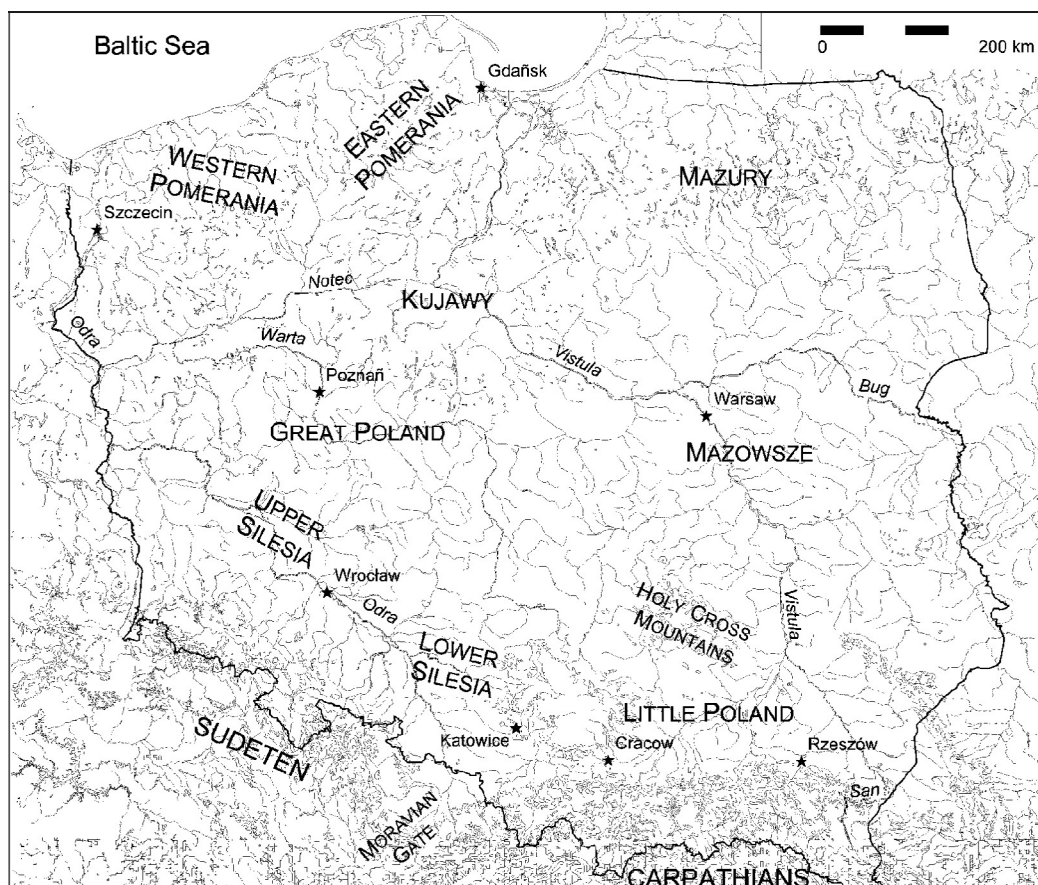

Fig. 1A. Most important regions of Poland with Greater Poland (Wielkopolska) and Kujawy



Fig. 1B. Western part of the Polish Lowland: soils (fol. Prusinkiewicz, Bednarek 1999). Thick horizontal lines mark areas with black soils

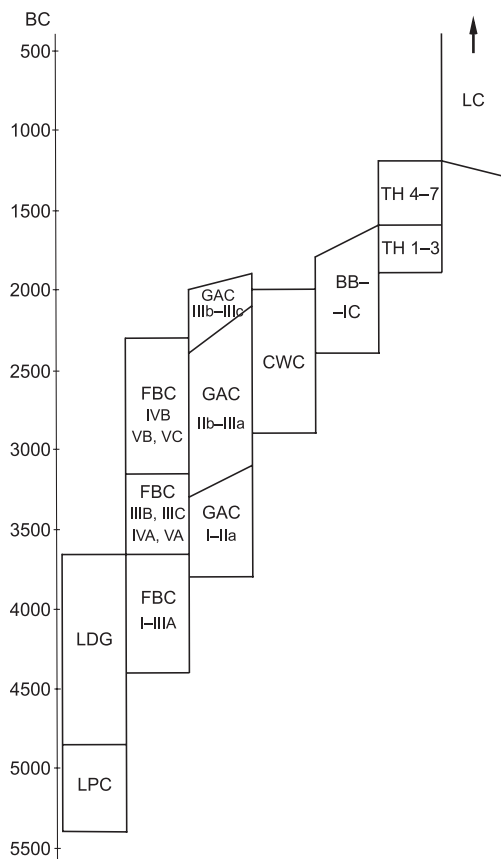

Fig. 2. General chronological framework
 LPC – Linear Pottery culture;
 LDG – Late Danubian Groups;
 FBC – Funnel Beaker culture;
 GAC – Globular Amphora culture;
 CWC – Corded Ware culture;
 BB – Bell Beakers;
 IC – Iwno culture;
 TH – Trzciniec Horizon;
 LC – Lusatian culture

of the upper Warta river (Fig. 1). The most intensive archaeological research was done in the eastern part of this area, namely in the Kujawy region (Fig. 1).

The stage of history we refer to covers the Neolithic and Bronze Age, i.e. the period of 5400 BC to 800 BC (Fig. 2). The beginning of the period is marked by the appearance of first agriculturalists on the Polish Lowland while its end date coincides with the rise of a system of fortified settlements (*grody*), belonging to the Lusatian culture.

Polish Lowland: natural and cultural background

Within the Polish Lowland one can find very diversified landscapes and soils (PRUSINKIEWICZ/BEDNAREK 1999): lake-lands, large valleys with peaty floor, sandy and clayey areas (in the FAO-UNESCO

glossary: *cambic arenosols*, *cambic podzols*, *luvisols* etc.), and plains with very fertile black soils (*mollic gleysols*, *gleyic phaeozems*). The latter form here a kind of ‘fertile islands’ (Fig. 1): they are large (ca. 845 sq.

km in the Kujawy region), smaller (100–300 sq. km in the Września or Kościan district) or really small (e.g. ca. 80 sq. km in the Szamotuły district).

The history of agriculture in the Lowland began on the ‘fertile islands’ and then for hundreds of years these areas were intensively used for human settlement. Continuously settled from the beginning of the Neolithic until the end of antiquity, they saw above all a cumulation of effects of long-term cultural and settlement transformations. This in turn had a favourable effect on the activities of societies inhabiting the ‘fertile islands’, making them cradles of Lowland cultural centres. Being part of a network of cultural contacts extending beyond the Lowland, the areas in question saw periodical influxes of new cultural patterns (ideas and technologies) and, under certain circumstances, new populations as well. It was from the Lowland centres that innovations (economic, social, religious, etc.) spread onto all of the Lowland. In this way, natural conditions combined with social and cultural factors to divide anew the Lowland with respect to settlement and culture. In the new space division, different from the Mesolithic one, the dominant position was held by central regions formed on the ‘fertile islands’.

The largest and most important of the Lowland centres was Kujawy for which we

have the largest database of sources and, hence, we shall often refer to it (see COFTA-BRONIEWSKA/KOŚKO 2002, here older literature).

Generally, a sequence of archaeological units in the Neolithic and the Bronze Age (Fig. 2) began at the onset of the Neolithic, about 5400 BC in the Kujawy region (ca. 5200 BC in other parts of the Lowland; CZERNIAK 2008), with the Danubian cultural circle: first, the Linear Pottery culture and then, ca. 4800 BC, Late Danubian groups, and ca. 4400 BC the first autochthonous Neolithic culture on the Lowland – the Funnel Beaker culture (CZERNIAK 2008). In the Late Neolithic (CZEBRESZUK et al. 2000, Fig. 1), we are dealing with the Funnel Beaker culture (the late phase) as well as with the Globular Amphora culture (from ca. 3800–3600 BC) and the Corded Ware culture (from 2900 BC). It ought to be stressed that still in the first half of the 3rd millennium BC, in some peripheral parts of the Lowland there lived epi-Mesolithic (also called para-Neolithic) hunters-gatherers (e.g. KOBUSIEWICZ, KABACIŃSKI 1993). Around 2300 BC, the Early Bronze Age began (CZEBRESZUK et al. 2000, Fig. 1) and then from 1300 BC onwards the Lusatian culture dominated here in the Late Bronze Age and at the beginning of the Early Iron Age (IGNACZAK 2002).

Perception of the Lowland natural environment in the Neolithic and the Bronze Age

The first agriculturalists on the Lowland belonged to a large cultural complex named Danubian, i.e. the Linear Pottery culture (Bandkeramik) and then the post-Linear Late Danubian groups (the Late Band Pottery culture). Settlers connected to the Linear Pottery culture spread to new territories in central and western Europe, including the Lowland on the Vistula and Odra rivers. On the Lowland they were newcomers from southern Poland. They settled almost exclusively areas of the most fertile soils that had been perceived as extremely good for early agriculture and its technological conditions.

A good example is the Kujawy region that consisted of several different parts: the Kujawy Plain, which is in the centre,

lakelands in the west and the south, and large valleys in the north and east. The very flat Kujawy Plain is covered with black soils. Both lakelands and valleys have a varied relief and are mainly covered with sandy or clayey soils (*cambic arenosols*, *cambic podzols*, *luvisols*, etc.). The Danubian newcomers exclusively settled the central part of the region (the Kujawy Plain), covered with black soils (Fig. 3B). What is remarkable, hunters-gatherers perceived the same part of Kujawy as not useful. One can find here only a few hunter-gatherer sites, dated to the Mesolithic as well as defined as post-Mesolithic, i.e. contemporaneous with the Danubians (Fig. 3A). But the settlers of the Linear Pottery culture formed here a large and quite long-lasting settle-

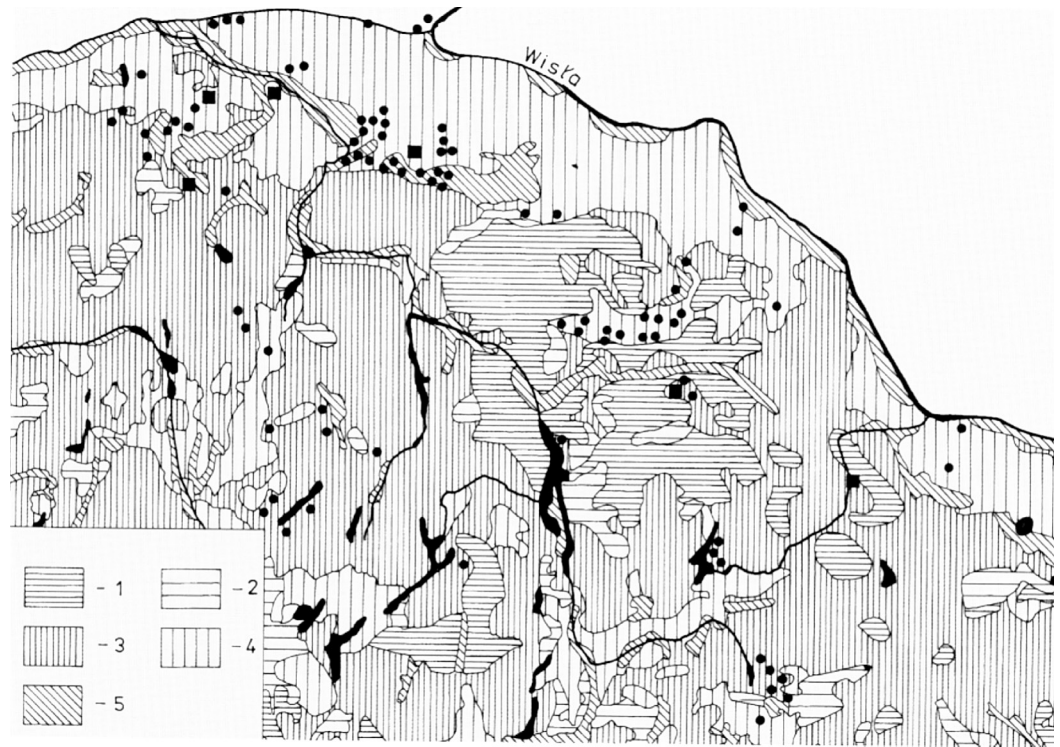

Fig. 3A. Comparison of site location in Kujawy – Mesolithic
1 – black soils;
2 – sandy soils

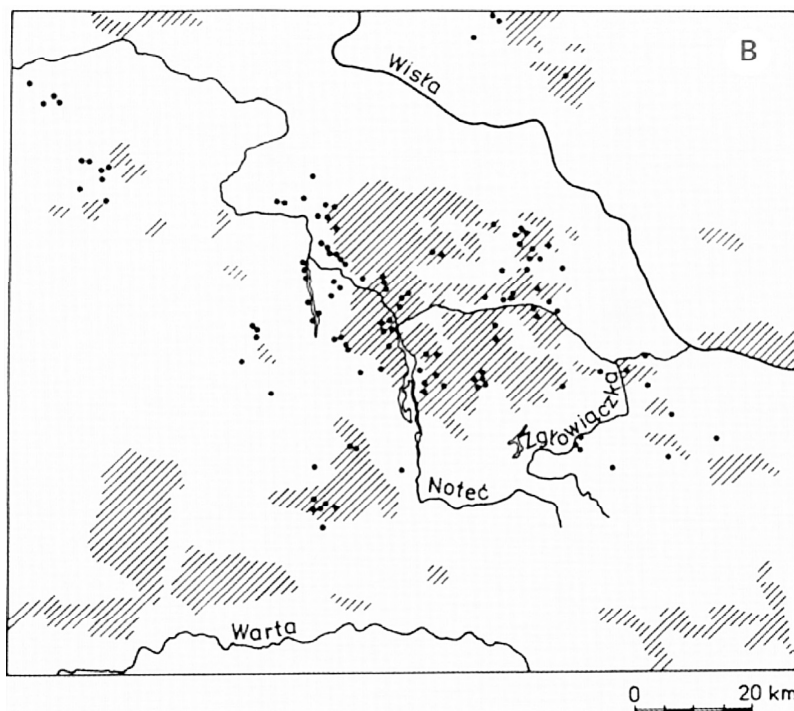

Fig. 3B. Comparison of site location in Kujawy – Linear Pottery culture (diagonal lines mark areas with black soils) (foll. COFTA-BRONIEWSKA/KOŚKO 2002)

ment structure (CZERNIAK 1994, GRYGIEL 2004). Its main elements were settlements consisting of long houses (see part 5). From the Early Neolithic, during the Middle Neolithic and the Late Neolithic as well as in the Bronze Age and even later, the Kujawy Plain was the most intensively used by people.

However, as human societies developed culturally (technologically, socially, etc.), the almost exclusive connection between

agricultural settlement and fertile soils, so strongly marked in the early Neolithic, is severed. The process starts in the Middle Neolithic with the rise of the Funnel Beaker culture, the populations of which took advantage of economic strategies adjusted to less fertile clayey and sandy soils. As a result, in the Middle Neolithic, settlement and economic dualism emerges in Kujawy.

For at that time there were two contemporaneous societies in the region which differed in the perception of the environment and had different selection criteria of land for use. The Late Danubian settlement was exclusively linked to black soil areas (CZERNIAK 1980, GRYGIEL 2008) while contemporaneous early Funnel Beaker (phase I) sites were located only on sandy areas and had the “tendency to use the environment to a maximum” (RZEPECKI 2004) by applying the slash-and-burn economy. Also, the types of settlements varied in both cases (see part 5). Later on, the people of the Funnel Beaker culture created new patterns of economic life, more flexible in selecting areas for settlement.

From ca. 3500 BC on, one of the most distinctive characteristics of the Polish Lowland is the wide variety of cultural groups that formed a kind of “cultural patchwork” (CZEBRESZUK/SZMYT 1998, 2001). These societies often coexisted

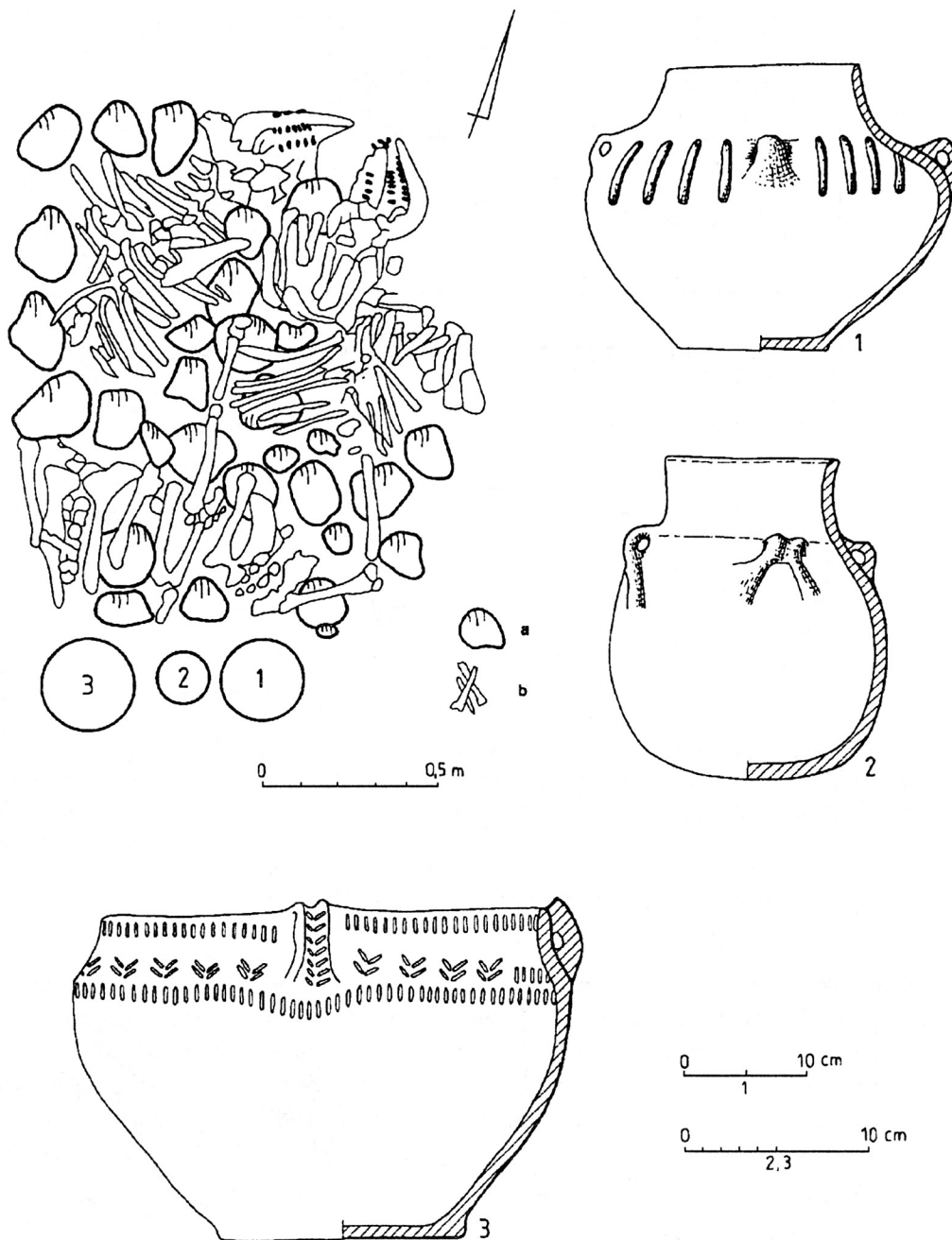

Fig. 4. Radziejów site 4, Kujawy. Animal grave of the Globular Amphora culture (foll. CZERNIAK/GRYGIEL/TETZLAFF 1977)

within a relatively small area and differed not only in their material culture but also in the social, economic and ritual activities. There still existed societies for whom crop cultivation was fundamental to the way of life (mainly late groups of the Funnel Beaker culture). However, other contemporary communities also emerged who relied on a different strategy for procuring food. The majority of groups inhabiting the Lowland began to place greater emphasis at this time on the rearing of domesticated animals as the basis of their livelihoods, e.g. populations of the Globular Amphora culture (SZMYT 1996) which in special circumstances deposited their animals,

mainly cattle, in special graves (Fig. 4). Moreover, the first populations appeared whose way of life was more mobile, mainly the Corded Ware culture (CZEBRESZUK 1996, 2000, 2000a).

Hence, Late Neolithic societies followed diverse economic strategies (from the domination of crop cultivation to that of animal rearing), making environmental limitations, so conspicuous earlier, disappear.

An example in point here is so called Prokopiak's Mount in Opatowice, in Kujawy (Fig. 5). This is a sandy morainic hill located just in the center of a flat plain covered with black soils. The Mount was intensively used and settled only at the end

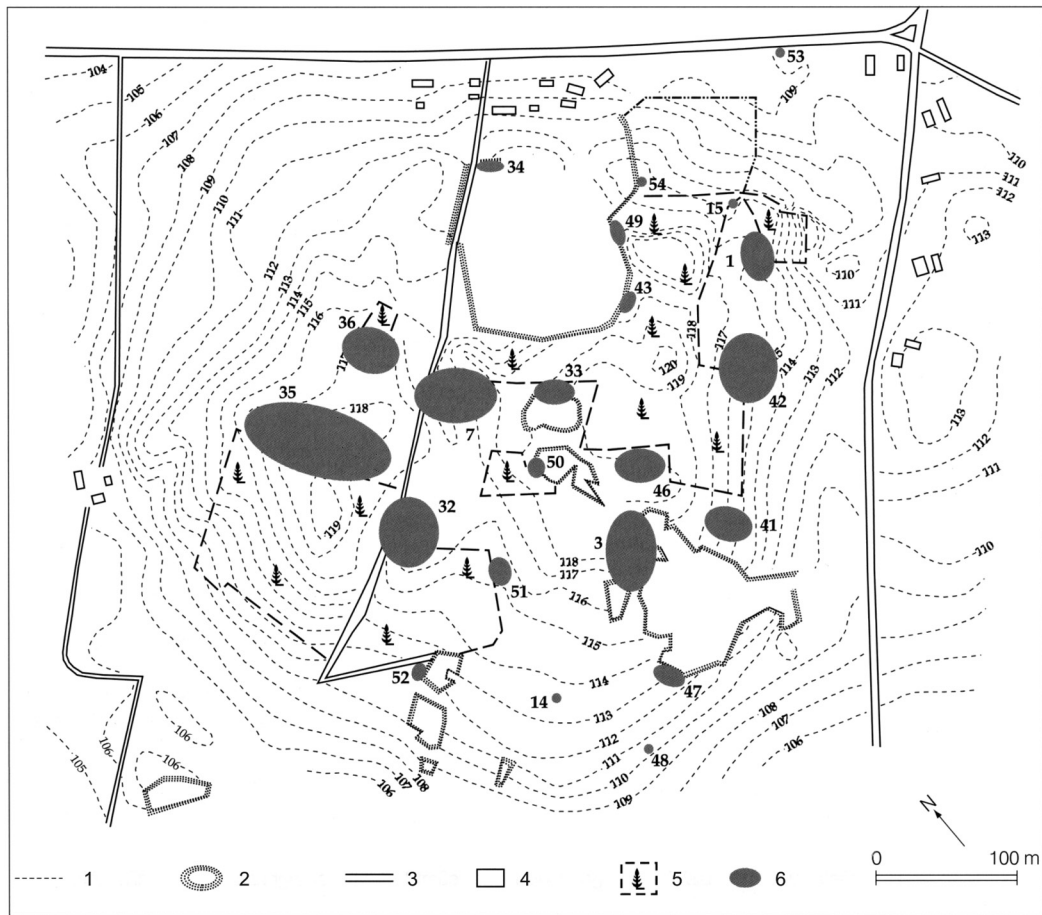

of the Middle Neolithic and especially in the Late Neolithic – the Early Bronze Age (KOŚKO/SZMYT 2006, 2007a, 2007b).

It is worth noting that throughout the stage in prehistory discussed here, the criteria for selecting areas for settlement relied above all on identifying suitable soils and terrain. In the latter aspect, a clear tendency was to choose relatively elevated locations (e.g. CZERNIAK 1994, SZMYT 1996). A connection to a hydrological network was always important, but owing to abundant pre-

cipitation on the Lowland, it did not determine the choice of locations for settlement so strongly as it did in other regions.

To end this part of the discussion, it is worth mentioning a special phenomenon of continuous use of certain places on the Lowland for ritual purposes. Some sites have been explored (e.g. KOŚKO 1989, 1991, KOŚKO/SZMYT 2007a, SZMYT 2008) where relics of ritual practices (chiefly funerary) have been unearthed. They were performed by various societies living in the

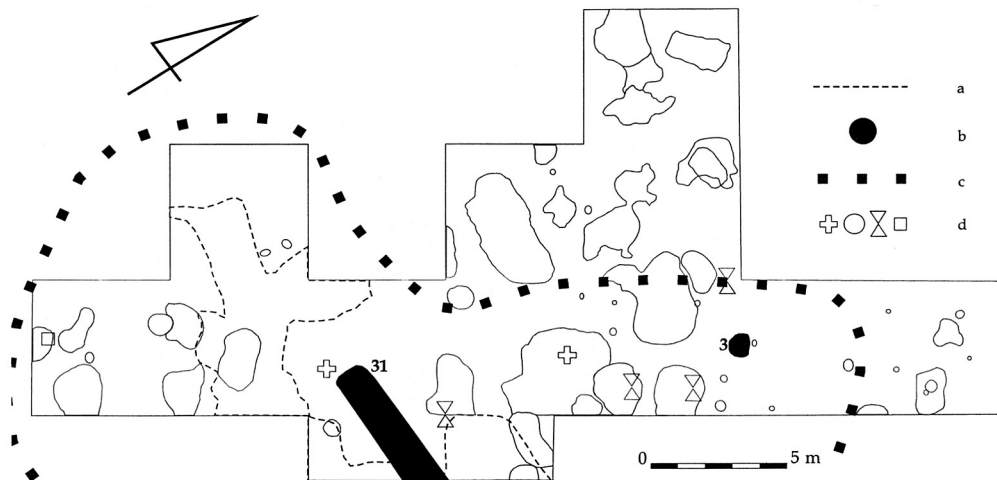

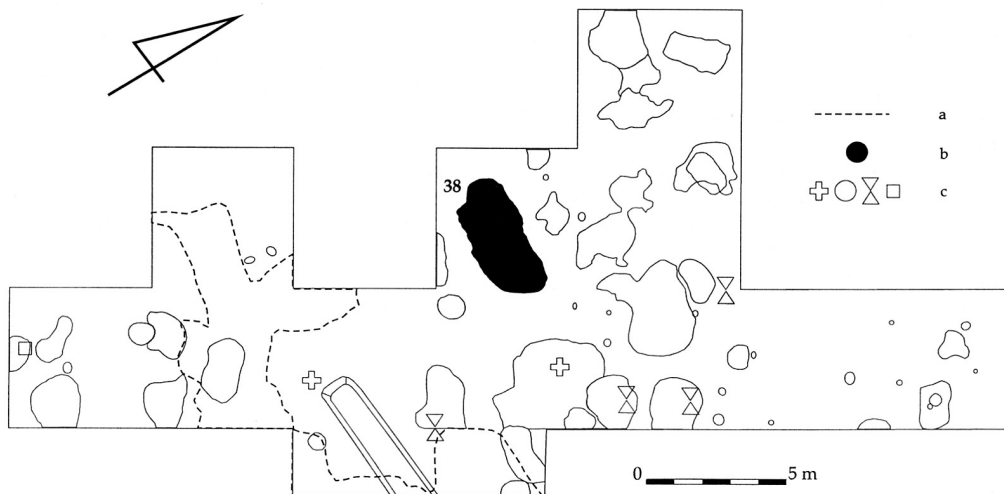

Fig. 6B. Opatowice site 1, Kujawy. The Globular Amphora culture (coll. CZEBRESZUK/KOŚKO/SZMYT 2007)

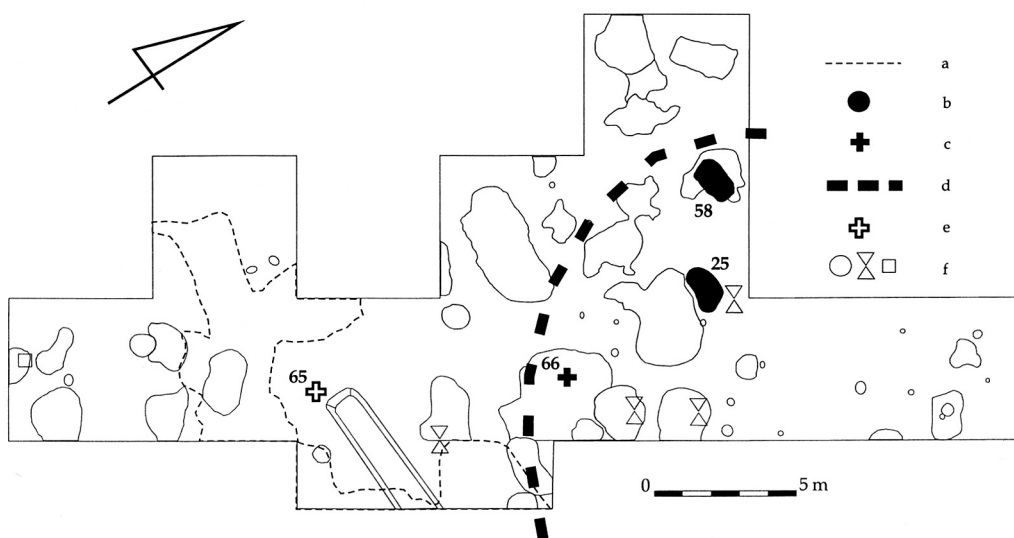

Fig. 6C. Opatowice site 1, Kujawy. Proto-Bronze Age (coll. CZEBRESZUK/KOŚKO/SZMYT 2007)

Neolithic and Early Bronze Age and populations of later stages of history (Fig. 6). Frequently, such a use of space was begun by the construction of a monumental funerary feature (e.g. a tomb of Funnel Beaker culture population), followed in later centuries

(or sometimes even millennia) by other graves or places of ritual practices located in its immediate vicinity. The phenomenon shows that distant traditions of hallowing space were recognized and respected.

Lowland's natural resources and their use

The Lowlands's resources consisted of soils, rocks, clay, water, plants, wood, animals, etc. Since the use of soils has already been discussed, we shall focus now on other resources.

First of all, local flint raw material (so called *Baltic cretaceous flint*; e.g. BALCER 1983) was of quite bad quality, too bad for making refined tools. This was the reason why Early/Middle Neolithic communities got the majority of flint they used from the south and it was good quality flint (Fig. 7A). However later, from the Late Neo-

lithic onwards, local poor quality raw materials were already accepted for most purposes (Fig. 7B).

Also the majority of stone raw material was local (erratic). We know of traces of exploitation of secondary erratic deposits from moraine pavement close to the earth surface (CHACHLIKOWSKI 1997). An example of a complex of small pit stone mines comes from Goszczewo (Kujawy region), dated to the Late Neolithic (Fig. 8). In the production of multi-purpose tools such as querns, grinders, polishing plates, polish-

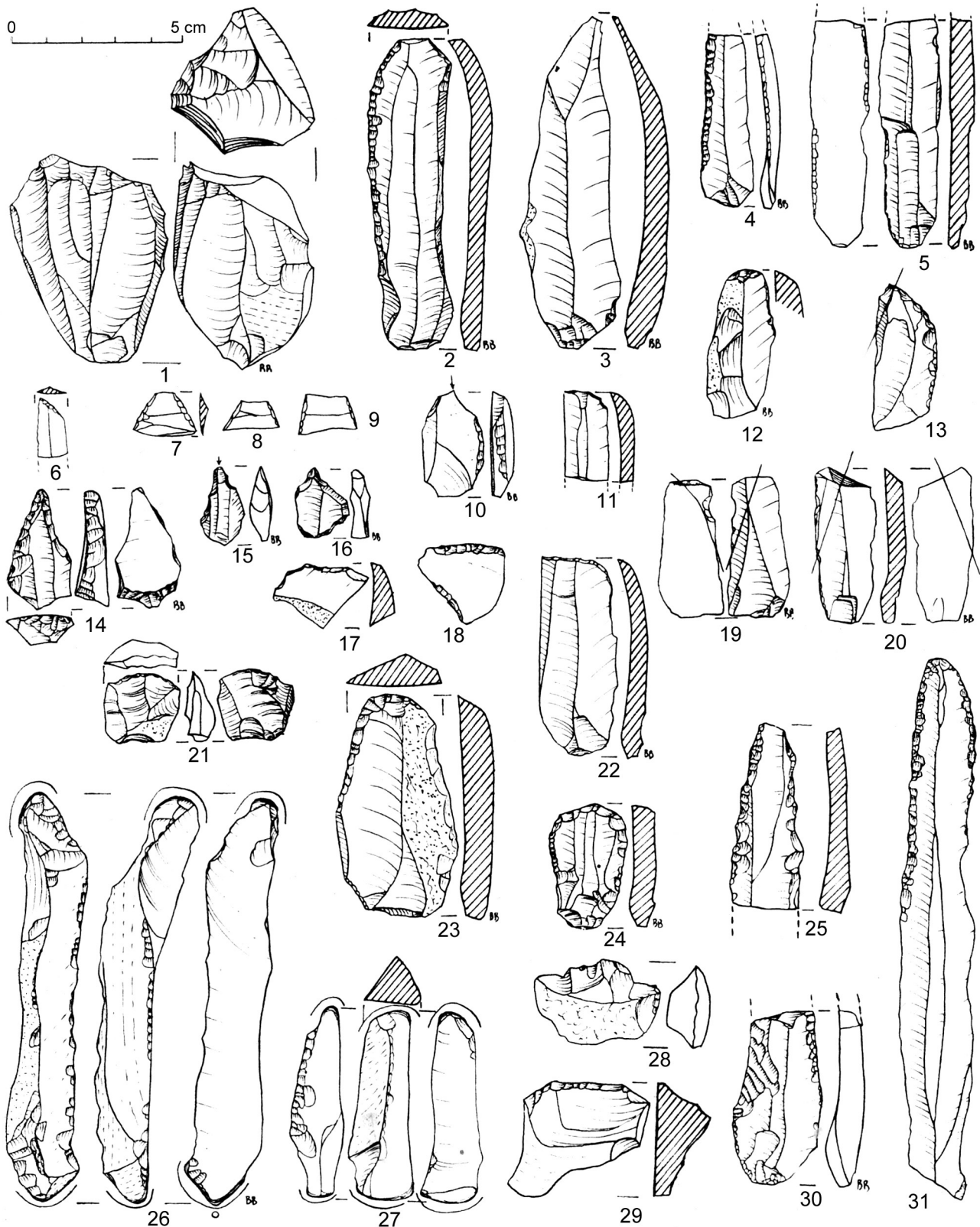
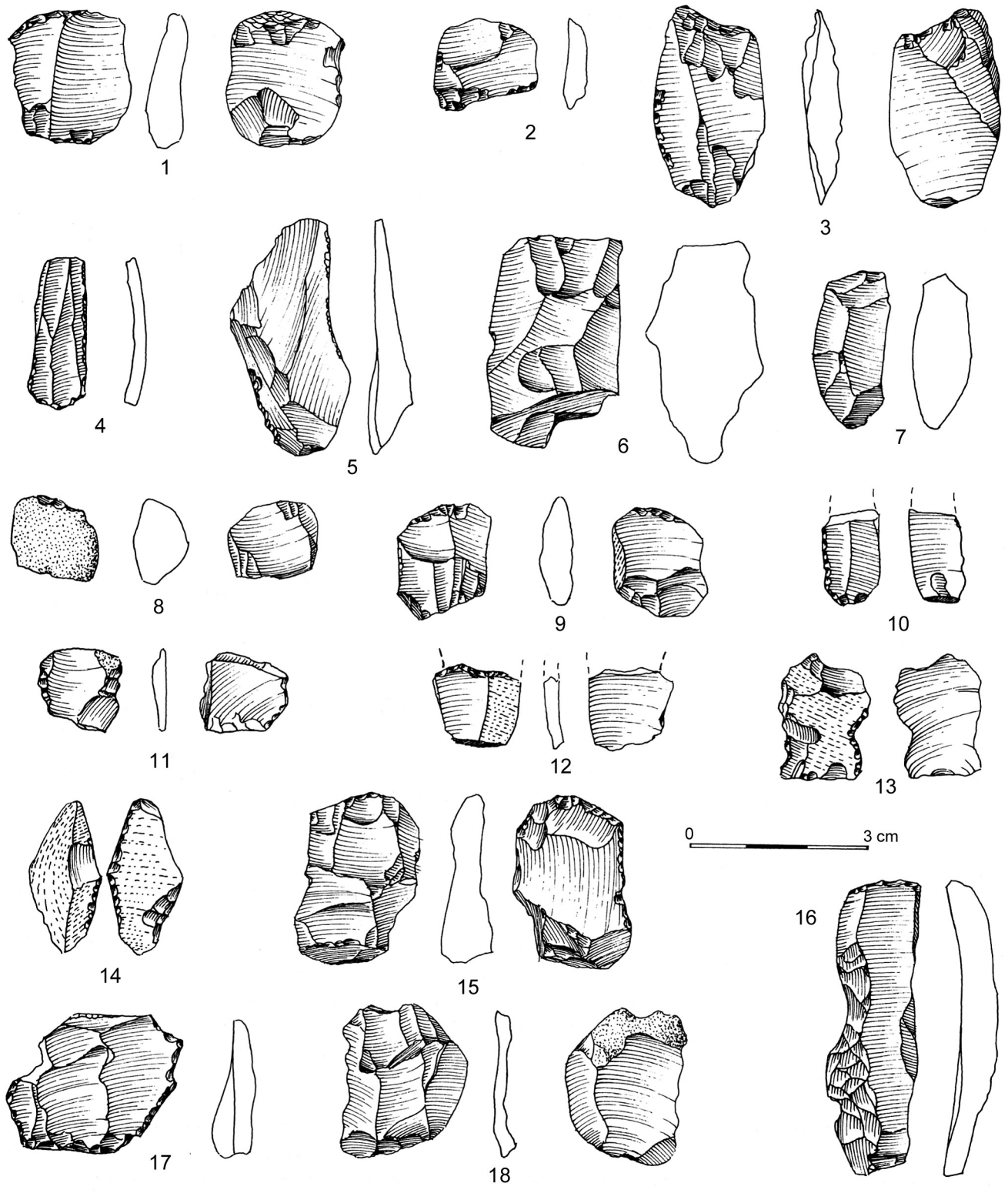

Fig. 7A. Kujawy. Two examples of flint using. Middle Neolithic societies (the early Funnel Beaker culture) – mainly flint from south Poland (foll. BALCER 1983) (foll. DOMAŃSKA/KABACIŃSKI 2000)

ers etc., raw material from the local sources (that is post-glacial erratic blocks) was used (CHACHLIKOWSKI 1997). The raw material structure of the tools fully agrees with that of the erratic boulders (Fig. 9). Only a small part of the refined tools or weapons (such as axes) was made from the very good quality rocks of southern origin.

The societies made a wide use of local deposits of Quaternary clay and silt. The former in particular were easily accessible as they lay shallow under the ground surface in many places on the Lowland. They were certainly used for building (as pisé) and for making pottery. Currently, traces of exploitation of silt deposits, of good usability



ity, especially plasticity, are dated to the Late Neolithic (DASZKIEWICZ/PRINKE 1999).

As regards the use of timber for building and heating, most data bear out the claim that basic tree species were used. On the Lowland these were pine and oak. From the Neolithic and the Bronze Age we have a lot of information on the processing of pine and birch wood into tar and pitch (PIETRZAK 2010).

The use of local animal resources is different. From the Early Neolithic till the end of the Bronze Age and even later local wild animals formed only a small (or even very small) part of consumed animals. Only epi-Mesolithic hunters-gatherers subsisted mainly on wild animals. This is clearly seen in the comparison of animal bone remains found at different settlements dated to the discussed stage in prehistory (Fig. 10).

Fig. 7B. Kujawy. Two examples of flint using. Late Neolithic societies (the Globular Amphora culture) – mainly local flint (coll. DOMAŃSKA/KABACIŃSKI 2000)

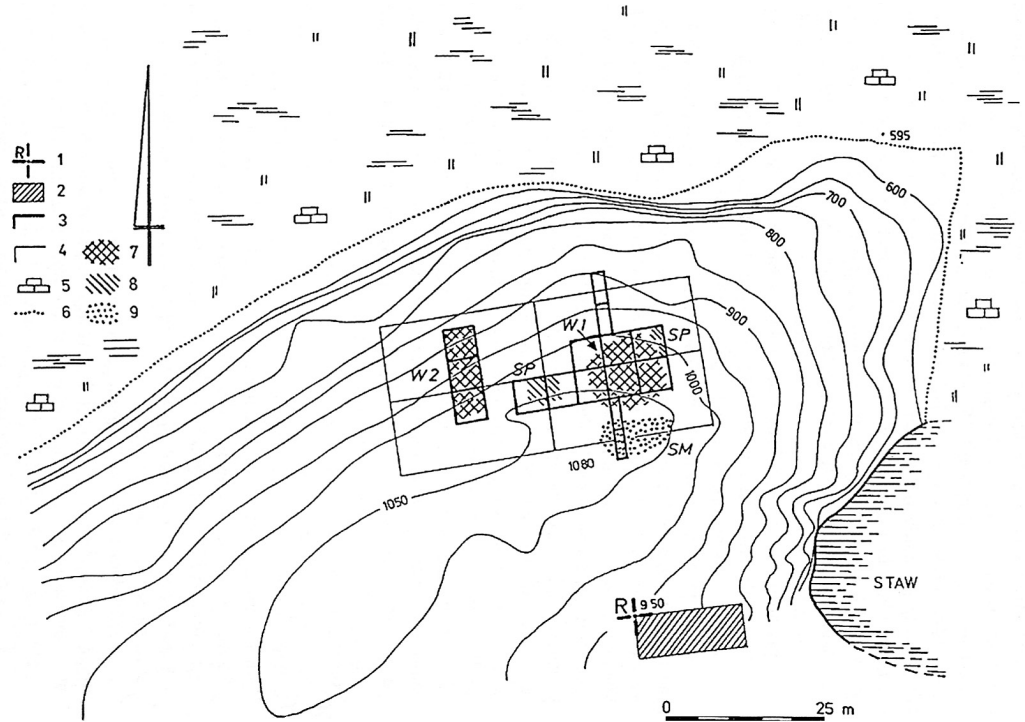

Fig. 8. Goszczewo site 13, Kujawy. Traces of exploitation of secondary erratic deposits from moraine pavement (coll. CHACHLIKOWSKI 1997)

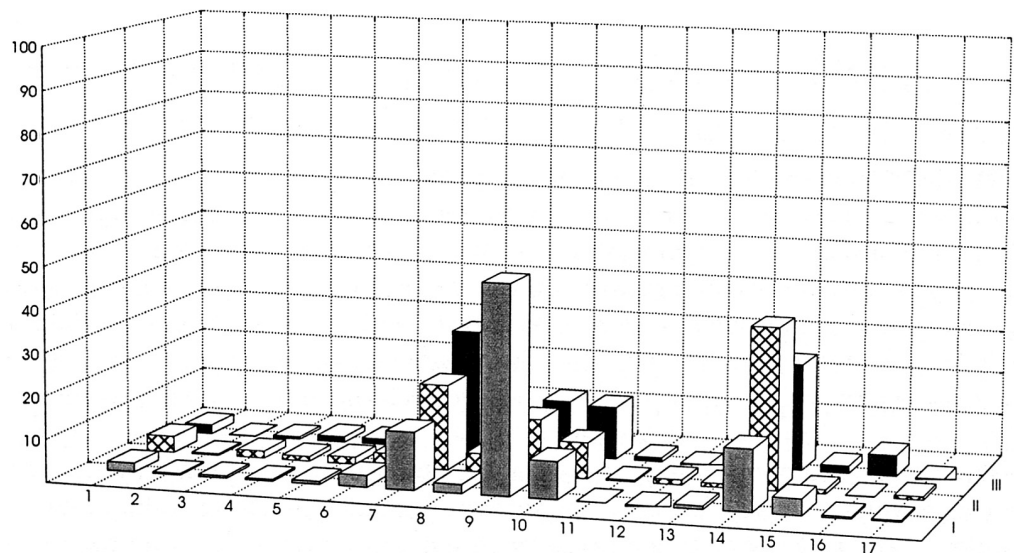

Fig. 9. Goszczewo site 13, Kujawy. The raw material structure of the tools and the erratic boulders (coll. CHACHLIKOWSKI 1997)
 I – structure of erratic rock raw material,
 II – raw material structure of stone tools of the Funnel Beaker culture,
 III – raw material structure of stone tools of the Globular Amphora culture,
 1–17 – different kinds of rocks

Too few observations prevent the assessment of the degree to which wild plants and fish were used (see MAKOWIECKI 2003).

Anthropogenic changes of natural Lowland environment

The best way to identify the transformations of the natural environment is to follow traits of deforestation and land use, which are detected in pollen diagrams or in pedologic and geomorphologic data. It must be stressed that periods of more intensive deforestation re-occurred in prehistoric times on the Lowland. However, they were interspersed with periods when

anthropopressure eased and forests expanded again. So we are dealing not with a linear evolution but rather with a sinuous development.

Beginning with the second half of the Atlantic period (in absolute chronology from the second half of the 6th millennium BC), traces of forest transformations, related to the activities of societies of agricul-

| Animal group | NP | UL | IF | LL |
|---|------|---------|----|---------|
| catfish (<i>Silurus glanis</i>) | - | 25 | - | - |
| pike (<i>Exos lucius</i>) | - | 14 | - | - |
| percid mainly perch (<i>Perca fluviatilis</i>) | - | 3+5 | - | - |
| bream (<i>Abrama bramis</i>) | - | 5 | - | - |
| cyprinid (Cyprinidae ge. et spec. indet.) | - | +60 | - | - |
| common toad (<i>Bufo bufo</i>) | - | 6(a) | - | - |
| European swamp turtle (<i>Emys orbicularis</i>) | - | 20(b) | - | - |
| whooper? swan (<i>Cygnus cygnus</i>) | - | 37(a) | - | - |
| duck, mainly pintail (<i>Anas acuta</i>) | - | 3 | - | - |
| moorhen (<i>Gallinula chloropus</i>) | - | 2 | - | - |
| beaver (<i>Castor fiber</i>) | 1 | - | - | - |
| ground vole (<i>Arvicola terrestris</i>) | - | 2(a) | - | - |
| otter (<i>Lutra lutra</i>) | - | 1 | - | - |
| horse (<i>Equus przewalskii</i>) | - | 2 | 1 | - |
| wild boar (<i>Sus scrofa</i>) | 1 | 1 | - | - |
| red deer (<i>Cervus elaphus</i>) | 4+2 | 15+1 | 1 | 23+2(c) |
| roe deer (<i>Cervus capreolus</i>) | 1 | 10+2 | - | - |
| elk (<i>Alces alces</i>) | 1+3 | 9+36 | - | 11+1 |
| European bison (<i>Bison bonasus</i>) | - | - | 1 | 5+8 |
| Total | 8+5 | +210+39 | 3 | 39+11 |
| Not identified (d) | +150 | 22 | - | R |

Fig. 10. Chwalim site 1, Greater Poland (Wielkopolska). The structure of animal remains in the site of epi-Mesolithic hunters-gatherers (foll. GAUTIER 1993)

turalists, are identified (e.g. JANKOWSKA 1980, TOBOLSKI (ed.) 1991, NORYSKIEWICZ 1995, MILECKA 1998, RALSKA-JASIEWICZOWA et al. 1998, MAKOHONIENKO 2000, PELISIAK et al. 2006, MAKOHONIENKO 2008, see a list of palynological sites in: NALEPKA 2004). The complexes of vegetation evidence of their multifarious activities are registered throughout the period in question and activity culminations are distinguished as successive anthropogenic phases. Generally speaking, the transformations are manifested in the growing thinning of forests and the appearance of synanthropic plants, including crop and animal grazing indicators, as well as ruderal communities and traces of fires. Successive episodes of decline in tree pollen share in favour of that of herbaceous plants are registered. However, the question of how permanent these changes were is debatable. They persisted or even cumulated in areas of high settlement intensity and continuity. The cycle of vegetation succession must have been disturbed there with respect to model analyses. It follows from the latter that in the simplest case, the succession from psammophytic grass to the mature phase of a

spontaneous pine forest *Peucedano-Pinetum* takes about 140 years. "For succession sequences leading to the growth of other forest communities the period is usually longer. For a multispecies deciduous forest, for instance a dry-ground forest, the period can be calculated to be at least 350 years." (FALIŃSKI 1986)

Permanent changes, whose connection with human activity is not obvious, though, involved variations in the share of the elm and hornbeam in Lowland forest communities. They fall on the period in prehistory discussed here. In Greater Poland (Wielkopolska) and Kujawy, two successive falls in the elm share are dated to 3900 BC and 3150 BC (MAKOHONIENKO 2008) whereas the inception of hornbeam dissemination falls on 4500–4000 BC (MAKOHONIENKO 2008).

The attached comparison of pollen diagram fragments illustrates well changes in vegetation communities in several regions of the Lowland.

The diagram from Chwalim (Fig. 11A) describes the situation in the peripheral regions of the Lowland not reached by the populations of early agriculturalists but ve-

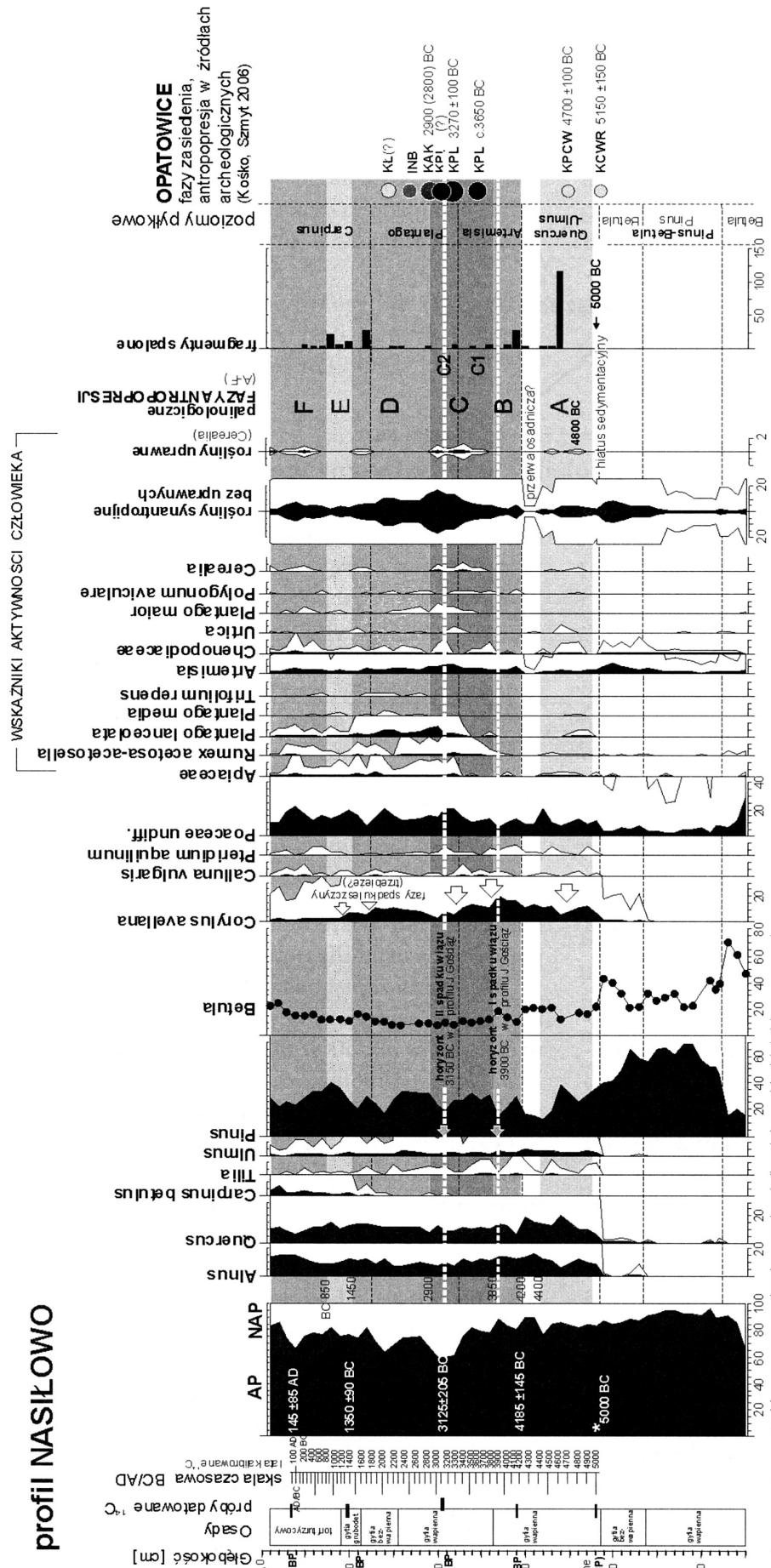

* wiek wyznaczony na podstawie tempa akumulacji osadu (wg modelu głębokościowo-czasowego)
 KCWR - kultura ceramiki wstęgowej rytej, KPCW - kultura amfor kulistych, INB - interstadium epoki neolitu i brązu, KL - kultura łużycka

Fig. 11A. Pollen diagrams referring to activities of different types of societies — Chwalim, epi-Mesolithic hunter-gatherers (foll. WASYLKOWA 1993)

Fig. 12. Dęby site 29A, Kujawy. Two levels of fossil soils (foll. HILDEBRANDT-RADKE 2008)

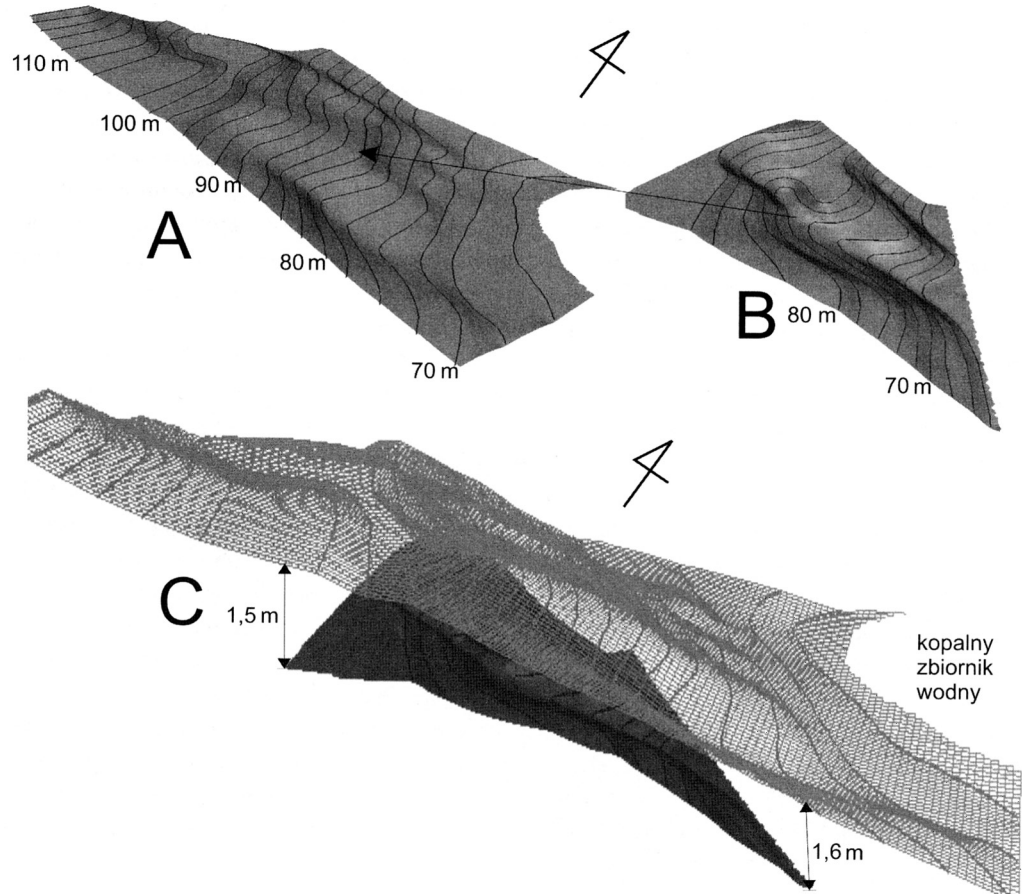
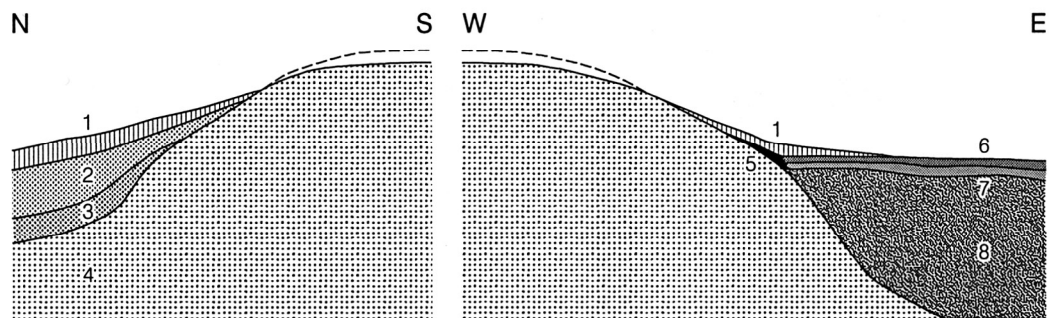

Fig. 13. Bruszczewo site 17, Great Poland (Wielkopolska). Phases of slope cover accumulation (foll. HILDEBRANDT-RADKE 2008)

- 1 – modern,
- 2 – Lusatian culture,
- 3 – Early Bronze Age,
- 4 – @@@@
- 5 – cultural layer of the Bronze Age (early and late),
- 6 – cultural layer of the Lusatian culture,
- 7 – cultural layer of the Early Bronze Age,
- 8 – peat deposits in the glacial trough



Creation of the cultural landscape

Within the title scope one could discuss many other examples of anthropopressure like introduction of new domestic mammals into the natural Lowland environment, new plants like cereals, but also buildings, graves, fields, pastures, etc.

The creation of the new anthropogenic landscape began at the beginning of the Neolithic. First agriculturalists on the Lowland (Danubian groups) built settlements that consisted chiefly of 1–3 monumental long houses (Fig. 14). Every house was used by an extended family group. Their farming is called “garden-type”.

Their impact on the natural environment was rather limited in space, but locally it could be relatively deep.

In the fifth millennium BC, this type of agriculture was continued and even intensified by groups of Late Danubian cultures, connected to the south as well. They created larger “village communities” only in fertile areas (Fig. 15), with their settlements consisting of several monumental long houses and several extended families. The settlement structure was rather concentrated and the impact on the natural environment was deeper but still local.

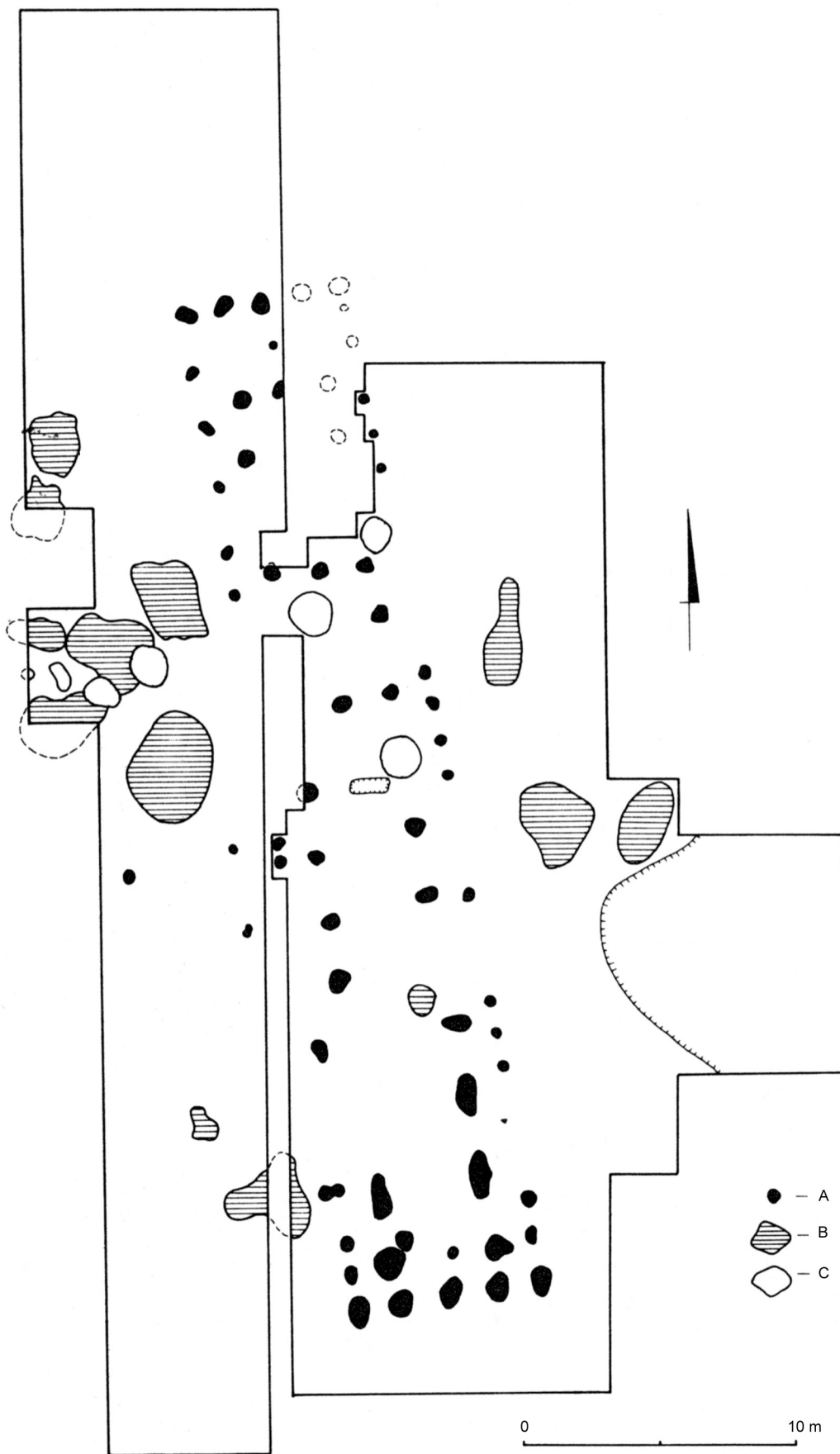

Fig. 14. Łojewo site 35, Kujawy. A house of the Linear Pottery culture (coll. CZERNIAK 1994)



Fig. 15. Miechowice site 4, Kujawy. Houses of the Late Danubian culture (coll. GRYGIEL 2008)

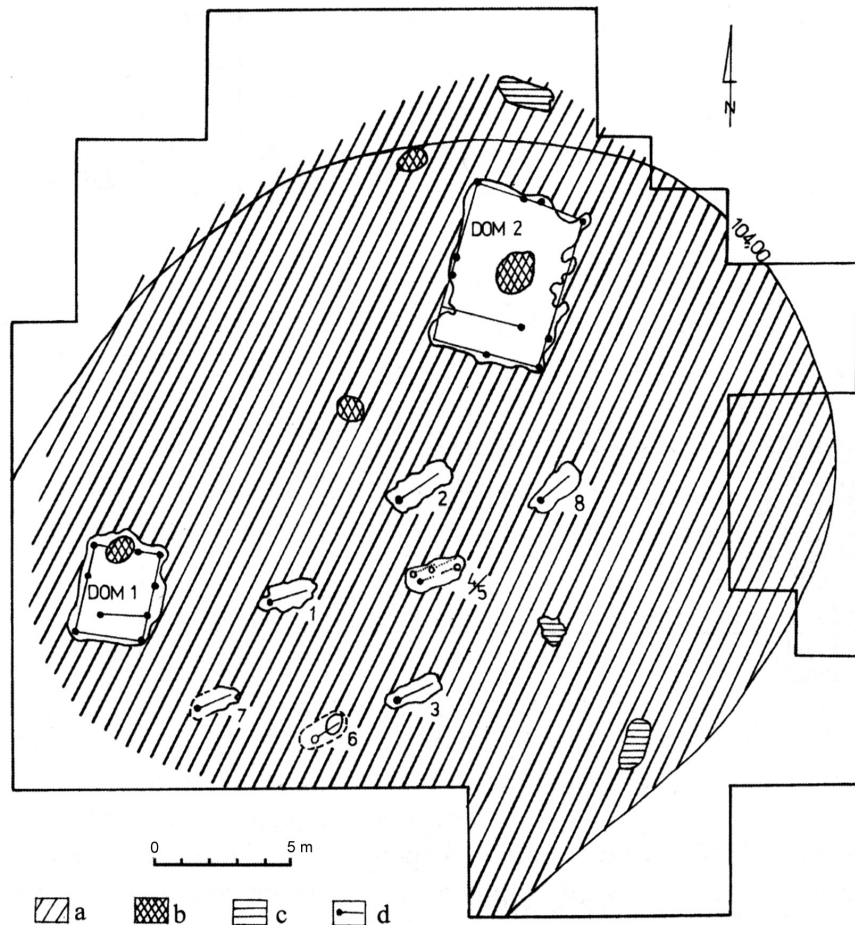

Fig. 16. Sarnowo site 1, Kujawy. Settlement of the early Funnel Beaker culture (coll. RZEPECKI 2004)

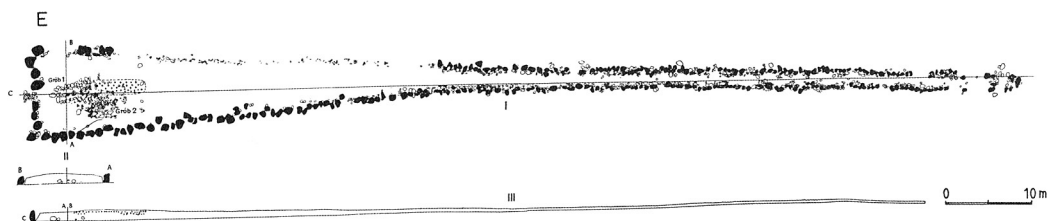

Fig. 17. Wietrzychowice site 1, Kujawy. A tomb of the so-called Kujavian type, the Funnel Beaker culture (foll. COFTA-BRONIEWSKA/KOŠKO 2002)

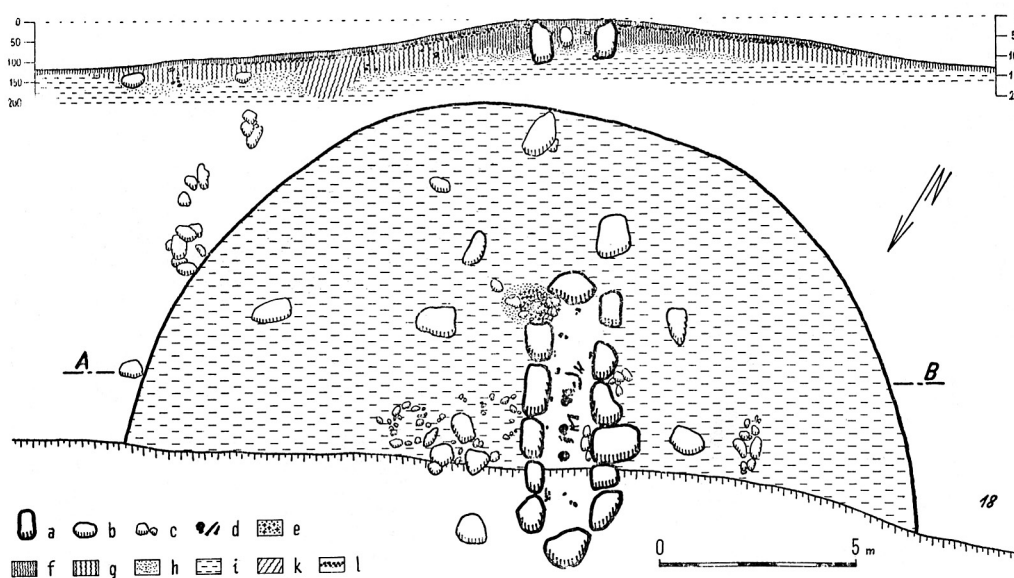

Fig. 18A. Mounds of the Globular Amphora culture (Złotowo site 4, Kujawy) (foll. WIŚLAŃSKI 1966 and CZEBRESZUK 2000)

In the Middle Neolithic, Funnel Beaker culture societies introduced to the Lowland a new type of settlement structure. Their dispersed settlements and campsites were formed by small family groups, which built rather small houses (Fig. 16). Of prime importance for their social and ritual life were cemeteries, consisting of long barrows that were also very significant for the landscape creation. The monumental tombs of the so-called Kujavian type were stone-earthen structures having the shape of an elongated trapezium sometimes more than 100 meters long. Their fronts, made of the largest boulders, were several meters high (Fig. 17). They were built in groups of several up to several dozen tombs, making their relics well visible against the landscape even after such locations were overgrown with forest.

What is important, the economy of the Funnel Beaker culture societies was aggressive towards the natural environment: they cleared by burning vast areas to grow cereals on them (e.g. KRUK 1993, CZEBRESZUK et al. 1997). As a result, some large expanses of the Lowland were deforested.

Then, a cultural landscape development on the Lowland was related to the activity of Late Neolithic societies, such as the Globular Amphora culture and the Corded Ware culture. In both cases, we are dealing with small family groups. Their settlements and campsites were rather small, with small houses or even huts. But they built large sepulchral monuments (Fig. 18): tombs constructed of big stones and earth or round earthen barrows (chiefly 5–10 metres in diameter and 2–3 metres high). Their subsistence is based more and more on the rearing of domesticated animals.

The Bronze Age, the beginnings of which are dated to ca. 2300 BC in this part of Europe, witnessed more intensive development of the cultural landscape. In some areas new settlement structures were established that were based on defensive (fortified) settlements. In such places settlement stabilized. A case in point is an Early Bronze settlement at Bruszczewo (Fig. 19) that continued at one place for maximum 400 years (2000–1600 BC), which was a rare occurrence at this part of Europe. A permanent occupation entailed a radical landscape

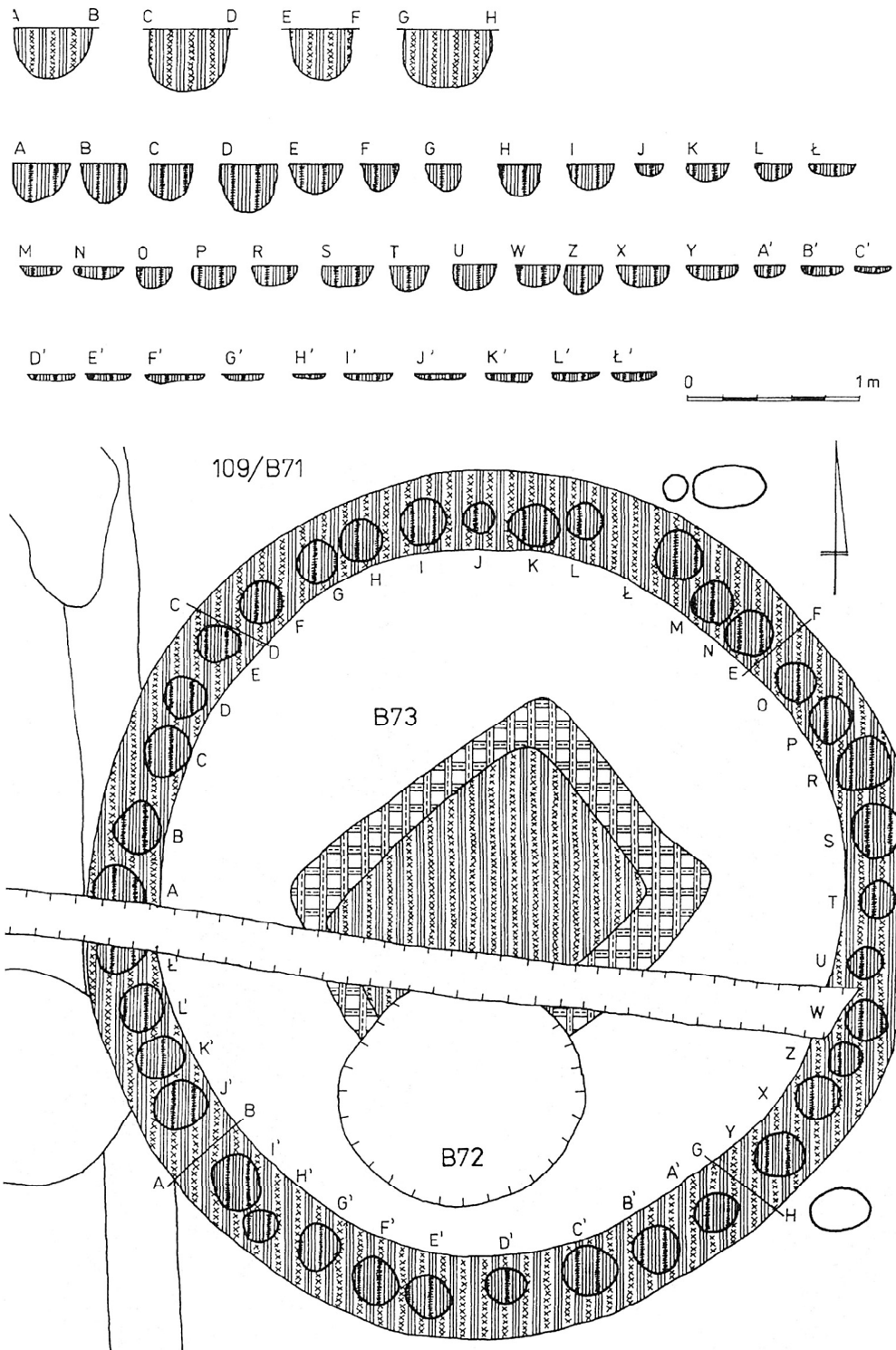

Fig. 18B. Corded Ware culture (Kuczkowo site 5, Kujawy) (coll. WIŚLAŃSKI 1966 and CZEBRESZUK 2000)

transformation. Such settlements needed lots of resources to build their moats or ramparts became a long-lasting element of the landscape. Around Bruszczewo, the landscape acquired a typical cultural character after 2000 BC. Also in the Early Bronze Age, there were places where barrows

formed anthropogenic components of the landscape. In that case, mounds were visibly larger than the those known from the Late Neolithic. Often more than 10 meters in diameter and over 4 meters high (Fig. 20), they had an earthen structure with a stone nucleus.

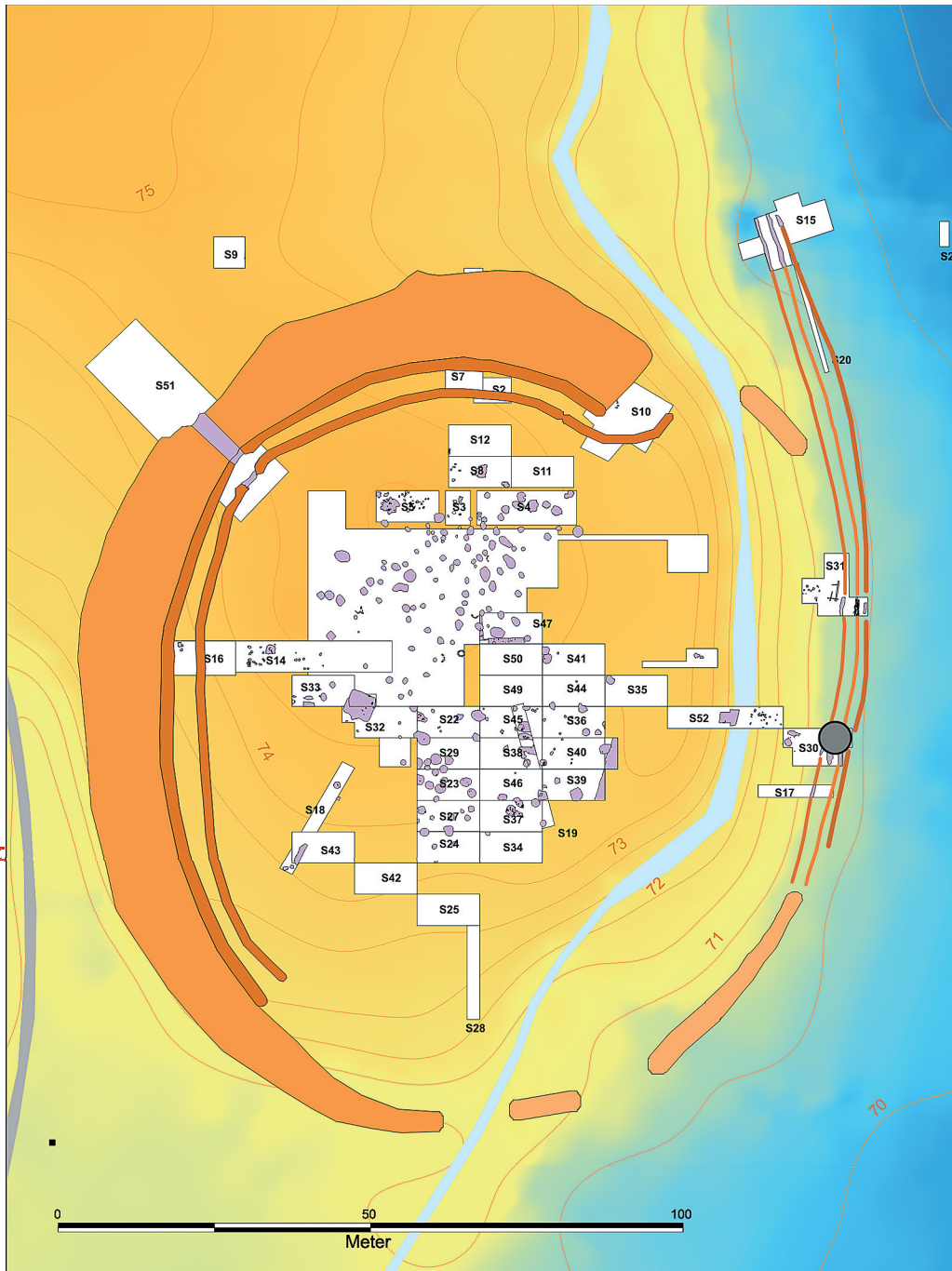

Fig. 19. Bruszczewo site 5, Greater Poland (Wielkopolska). An Early Bronze Age fortified settlement (prepared by J. KNEISEL)

Nevertheless, in many parts of Polish Lowland radical landscape changes took place only in the Late Bronze Age and were

related to the activities of Lusatian culture populations.

Conclusions

The Neolithic share in creating a cultural landscape was in some places strong but short-lived for it was limited to settlement activities and minor forest clearings. Stable man-made landscape elements included local forest clearings and sepulchral structures. In the Bronze Age, locally, permanent human settlement entailed a radical

landscape transformation. At that time, in some parts of the Lowland, the human impact was very strong.

From this point of view, Neolithic and Bronze Age communities on the Polish Lowland were on the way from a natural landscape to a cultural one.

Fig. 20. Łęki Małe,
Greater Poland
(Wielkopolska). An Early
Bronze Age barrow
(photo by M. Jaeger)



References

- BALCER B. 1983, *Wytwórczość narzędzi krzemiennych w neolicie ziem Polski*, Wrocław–Warszawa–Kraków–Gdańsk–Łódź.
- CHACHLIKOWSKI P. 1997, *Kamieniarstwo późnoneolitycznych społeczeństw Kujaw*, Poznań.
- COFTA-BRONIEWSKA A./KOŚKO A. 2002, *Kujawy w pradziejach i starożytności*, Inowrocław–Poznań.
- CZEBRESZUK J. 1996, *Spoleczności Kujaw w początkach epoki brązu*, Poznań.
- CZEBRESZUK J. 2000, Animal Husbandry and Pastoralism in the Late Neolithic and Early Bronze Age/Hodowcy i pastersze u schyłku epoki kamienia i w początkach epoki brązu. In: CHŁODNICKI M./KRZYŻANIAK L. (eds), *Pipeline of Archaeological Treasures/Gazociąg pełen skarbów archeologicznych*, Poznań: 39–47.
- CZEBRESZUK J. 2000a, Osadnictwo kultury ceramiki sznurowej. In: KOŚKO A. (ed.), *Archeologiczne badania ratownicze wzdłuż trasy gazociągu tranzytowego. Tom III. Kujawy. Część 4. Osadnictwo kultur późnoneolitycznych oraz interstadium epok neolitu i brązu: 3900–1400/1300 przed Chr.*, Poznań: 423–454.
- CZEBRESZUK J./HILDEBRANDT-RADKE I./SZMYT M. 1997, *Krajobrazotwórcza działalność człowieka w centralnej części Wysoczyzny Kujawskiej w neolicie i wczesnej epoce brązu*, *Folia Praehistorica Posnaniensia*, t. 8: 7–31.
- CZEBRESZUK J./KOŚKO A./MAKAROWICZ P./SZMYT M. 2000, Podsumowanie. In: KOŚKO A. (ed.), *Archeologiczne badania ratownicze wzdłuż trasy gazociągu tranzytowego. Tom III. Kujawy. Część 4. Osadnictwo kultur późnoneolitycznych oraz interstadium epok neolitu i brązu: 3900–1400/1300 przed Chr.*, Poznań: 569–571.
- CZEBRESZUK J./KOŚKO A./SZMYT M. 2007, Etapy i formy wykorzystania przestrzeni stanowiska w pradziejach. In: KOŚKO A., SZMYT M., *Opatowice-Wzgórze Prokopiaka, tom II*, Poznań: 297–305.
- CZEBRESZUK J./SZMYT M. 1998, Der Epochenumbbruch vom Neolithikum zur Bronzezeit im polnischen Tiefland am Beispiel Kujawiens, *Praehistorische Zeitschrift* 73 (2): 167 – 232.
- CZEBRESZUK J./SZMYT M. 2001, The 3rd Millennium BC in Kujawy in the Light of ¹⁴C Dates. In: CZEBRESZUK J./MÜLLER (eds.), *Die absolute Chronologie in Mitteleuro-*

- pa 3000–2000 v.Chr./The Absolute Chronology of Central Europe 3000–2000 BC, Studien zur Archäologie in Ostmitteleuropa/Studia nad Pradziejami Europy Środkowej 1, Poznań-Bamberg-Rahden/Westf.: 177–208.
- CZEBRESZUK J., SZMYT M. 2008, Siedlungsformen des 3. Jahrtausends v.Chr. in der polnischen Fiefebene (Kulturen der Trichterbecher, Kugelamphoren und Schnurkeramik). Stand und Perspektiven der Untersuchungen. In: DÖRFLER W./MÜLLER (eds), Umwelt – Wirtschaft – Siedlungen im dritten vorchristischen Jahrtausend Mitteleuropas und Südschwedens, Neumünster: 219–242.
- CZERNIAK L. 1980, *Rozwój społeczeństw kultury późnej ceramiki wstęgowej na Kujawach*, Poznań.
- CZERNIAK L. 1994, *Wczesny i środkowy okres neolitu na Kujawach 5400–3650 p.n.e.*, Poznań.
- CZERNIAK L. 2008, Najstarsze społeczności rolnicze. Nowa epoka/A New epoch: the oldest agricultural societies. In: KOBUSIEWICZ M. (ed.), *Pradzieje Wielkopolski. Od epoki kamienia do średniowiecza*, Poznań: 147–201.
- CZERNIAK L./GRYGIEL R./TETZLAFF W. 1977, Néolithique. Civilisations de Lengyel, des Amphores Sphériques et des Coupes en Entonnoir, *Inventaria Archaeologica, Pologne*, fasc. XXXIX, Warszawa.
- DASZKIEWICZ M./PRINKE D. 1999, *Archaeo-keramologische Untersuchungen zur Trichterbecherkultur in Kujawien (Zentralpolen)*, *Ethnographisch-Archaeologische Zeitschrift*, t.40(3): 299–336.
- DOMAŃSKA L./KABACIŃSKI J. 2000, Krzemieniarstwo społeczeństw późnoneolitycznych. In: KOŚKO (ed.), *Archeologiczne badania ratownicze wzdłuż trasy gazociągu tranzytowego. Tom III. Kujawy, Część 4. Osadnictwo kultur późnoneolitycznych oraz interstadium epok neolitu i brązu: 3900–1400/1300 przed Chr.*, Poznań: 379–392.
- FALIŃSKI J.B. 1986, Sukcesja roślinności na nieużytkach porolnych jako przejaw dynamiki ekosystemu wyzwolonego spod długotrwałej presji antropogenicznej, cz. I, *Wiadomości Botaniczne*, t. 30(1): 25–50.
- GAUTIER A. 1993, The faunal remains. In: KOBUSIEWICZ M./KABACIŃSKI J., *Chwalim. Subboreal hunters-gatherers of the Polish Plain*, Poznań: 79–89.
- GRYGIEL R. 2004, *Neolit i początki epoki brązu w rejonie Brześcia Kujawskiego i Osłonek, tom I, Wczesny neolit. Kultura ceramiki wstęgowej rytu* The Neolithic and Early Bronze Age in the Brześć Kujawski and Osłonki Region, vol. I, Early Neolithic. Linear Pottery Culture, Łódź.
- GRYGIEL R. 2008, *Neolit i początki epoki brązu w rejonie Brześcia Kujawskiego i Osłonek, tom II, Środkowy neolit. Grupa brzesko-kujawska kultury lengielskiej*/The Neolithic and Early Bronze Age in the Brześć Kujawski and Osłonki Region, vol. II, Middle Neolithic. The Brześć Kujawski Group of the Lengyel Culture, Łódź.
- HAAS J.-N./WAHLMÜLLER N. 2010, *Przemiany środowiska, wegetacji i flory w ramach osadnictwa epoki brązu w Bruszczewie oraz gospodarcze użytkowanie otoczenia osady/Floren-, Vegetations- und Milieueränderungen im Zuge der bronzezeitlichen Besiedlung von Bruszczewo (Polen) und der landwirtschaftlichen Nutzung der umliegenden Gebiete*. In: MÜLLER J./CZEBRESZUK J./KNEISEL J. (eds), *Bruszczewo II. Badania mikroregionu osadniczego z terenu Wielkopolski/Ausgrabungen und Forschungen in einer prähistorischen Siedlungskammer Großpolens*, Bonn: 50–81.
- HILDEBRANDT-RADKE I. 2008, Zróżnicowanie dynamiki przemian geosystemów Kujaw „białych” i „czarnych” w warunkach pradziejowej antropopresji. In: BEDNARCZYK J./CZEBRESZUK /MAKAROWICZ P./SZMYT M. (eds.), *Na pograniczu światów. Studia z pradziejów międzymorza bałtycko-pontyjskiego ofiarowane Profesorowi Aleksandrowi Kośko w 60. rocznicę urodzin*, Poznań: 123–140.
- IGNACZAK M. 2002, *Ze studiów nad genezą kultury lużyckiej w strefie Kujaw*, Poznań.
- JANKOWSKA B. 1980, Szata roślinna okolic Gopła w późnym glacie i holocenie oraz wpływ osadnictwa na jej rozwój w świetle badań paleobotanicznych, *Przegląd Archeologiczny*, t. 27: 5–41.
- KOBUSIEWICZ M./KABACIŃSKI J. 1993, *Chwalim: Subboreal hunters-gatherers of the Polish Plain*, Poznań.
- KOŚKO A. 1989, *Formy eksploatacji terenu stanowiska w epokach neolitu i brązu*. In: COFTA-BRONIEWSKA A. (ed.), *Miejsce pradziejowych i wczesnośredniowiecz-*

- nych praktyk kultowych w Kruszy Zamkowej województwo bydgoskie, stanowisko 13, Poznań: 13–61.
- KOŚKO A. 1991, *Ze studiów nad kujawską enklawą naddunajskiej cywilizacji wczesno-brązowej*, Poznań–Inowrocław.
- KOŚKO A./SZMYT M. 2006, *Opatowice – Wzgórze Prokopiaka, tom I, Studia i materiały do badań nad późnym neolitem Wysoczyzny Kujawskiej I*, Poznań.
- KOŚKO A./SZMYT M. 2007a, *Opatowice – Wzgórze Prokopiaka, tom II, Studia i materiały do badań nad późnym neolitem Wysoczyzny Kujawskiej II*, Poznań.
- KOŚKO A./SZMYT M. 2007b, *Opatowice – Wzgórze Prokopiaka, tom III, Studia i materiały do badań nad późnym neolitem Wysoczyzny Kujawskiej III*, Poznań.
- KRUK J. 1993, Rozwój społeczno-gospodarczy i zmiany środowiska przyrodniczego wyżyn lessowych w neolicie (4800 – 1800 bc), *Sprawozdania Archeologiczne*, t. 45: 7–17.
- MAKOHONIENKO M. 2000, *Przyrodnicza historia Gniezna*, Bydgoszcz–Poznań.
- MAKOHONIENKO M. 2008, Szata roślinna i etapy rozwoju krajobrazu kulturowego Kujaw w rejonie Pagórków Radziejowskich w okresie neolitu i epoce brązu. Podstawy palinologiczne. In: BEDNARCZYK J./CZEBRESZUK J./MAKAROWICZ P./SZMYT M. (eds.), *Na pograniczu światów. Studia z pradziejów międzymorza bałtycko-pontyjskiego ofiarowane Profesorowi Aleksandrowi Kośko w 60. rocznicę urodzin*, Poznań: 353–370.
- MAKOWIECKI D. 2003, *Historia ryb i rybołówstwa w holocenie na Niżu Polskim w świetle badań archeoichtiologicznych*, Poznań.
- MILECKA K. 1998, Badania paleobotaniczne na stanowisku archeologicznym w Rybinach na Kujawach, *Badania Fizjograficzne nad Polską Zachodnią*, Seria A – Geografia Fizyczna, t. 49: 147–162.
- NALEPKA D. 2004, Sites used for drawings the isopollen maps of Poland. In: RALSKA-JASIEWICZOWA et al. (eds), *Late Glacial and Holocene History of Vegetation in Poland Based on Isopollen Maps*, Kraków: 417–423.
- NORYŚKIEWICZ B. 1995, Zmiany szaty roślinnej okolic Jeziora Biskupińskiego pod wpływem czynników naturalnych i antropogenicznych w późnym glacie i holocenie. In: NIEWIAROWSKI W. (ed.), *Zarys zmian środowiska geograficznego okolic Biskupina pod wpływem czynników naturalnych i antropogenicznych w późnym glacie i holocenie*, Toruń: 147–179.
- PELISIAK A./RYBICKA M./RALSKA-JASIEWICZOWA M. 2006, *From the Mesolithic to Modern Times. Settlement Organization and Economy Recorded in Annually Laminated Sediments of the Lake Gościąg (Central Poland)*. *Collectio Archaeologica Ressoviensis*, t. 2, Rzeszów.
- PIETRZAK S. 2010, *Zastosowanie i technologie wytwarzania dziegiu przez społeczeństwa międzyrzecza Dniepru i Łaby od VI do II tysiąclecia BC*, Poznań.
- PRUSINKIEWICZ Z./BEDNAREK R. 1999, Głęb. In: STARKEL L. (ed.), *Geografia Polski. Środowisko przyrodnicze*, Warszawa: 373–396.
- RALSKA-JASIEWICZOWA M., GOSLAR T., MADEYSKA T., STARKEL L. (eds.) 1998, *Lake Gościąg, Central Poland. A Monographic Study*, Kraków.
- RZEPECKI S. 2004, *Spoločności środkowoneolitycznej kultury pucharów lejkowatych na Kujawach*, Poznań.
- SZMYT M. 1996, *Spoločności kultury amfor kulistych na Kujawach*, Poznań.
- SZMYT M. 2010, Kurhany w kulturze amfor kulistych. Dwa przykłady z Kujaw. In: KOWALEWSKA-MARSZALEK H./WŁODARCZAK P. (eds.), *Kurhany i obrządek pogrzebowy w IV–II tysiącleciu p.n.e.*, Kraków–Warszawa: 109–122.
- TOBOLSKI K. (ed.) 1991, *Wstęp do paleoekologii Lednickiego Parku Krajobrazowego*, Biblioteka Studiów Lednickich I, Poznań.
- WASYLIKOWA K. 1993, History of vegetation. In: KOBUSIEWICZ M./KABACIŃSKI J. (eds.), *Chwalim: Subboreal hunters-gatherers of the Polish Plain*, Poznań: 91–101.
- WIŚLAŃSKI T. 1966, *Kultura amfor kulistych w Polsce północno-zachodniej*, Wrocław.