

Svitlana SVIRKO¹

Zhytomyr Polytechnic State University, Ukraine
ORCID: 0000-0001-9157-4672

DOI : 10.14746/ps.2024.1.19

Valentyna KSENDZUK

Zhytomyr Polytechnic State University, Ukraine
ORCID: 0000-0001-7670-7350

Oleg DZYUBENKO

Zhytomyr Polytechnic State University, Ukraine
ORCID: 0000-0002-4871-4964

BUDGET SECURITY: PUBLIC ADMINISTRATION MECHANISMS IN UKRAINE

INTRODUCTION

Public administration in Ukraine is at the stage of active mastery of a wide range of objects, which is explained by the traditionally extremely significant role of the state in the life of society. One of its central segments in modern conditions is state security in the entire structure of its components. The latter is identified in different ways; however, the point of intersection of vector scientific approaches is economic security.

Among other elements of economic security, the leading place is occupied by budgetary security, the nature of which determines its initial position in the aggregate of other types and subspecies of state security: we are talking about its financial and supporting role. Such an outstanding characteristic of fiscal security should automatically attract the attention of not only practitioners but also scientists in the field of public administration. However, modern approaches to the development of its problems in the state-administrative aspect are distinguished by a certain lack of system and fragmentation and the scientific mastery of individual aspects of the latter without taking into account its fundamental essence, connection, and subordination, of course, ensures the growth of exclusively scholastic knowledge.

The relevance of such a task is enhanced by the disappointing permanent state of budget security in Ukraine today, which one of the authors studied in a monographic study (Svirko, 2021). An analysis of relevant macroeconomic indicators for the period 2010–2020 shows that fiscal security as a whole never reached an optimal or satisfactory level.

¹ This article is licensed under the Creative Commons – Attribution – ShareAlike 4.0 (CC-BY-SA 4.0) license.

Artykuł udostępniany jest na licencji Creative Commons – Uznanie autorstwa – Na tych samych warunkach 4.0 (CC-BY-SA 4.0).

The resulting indicative indicators obtained during the study make it possible to recognize the current state of public administration of budgetary security as extremely unsatisfactory. This once again confirms the need for a comprehensive scientific study in this area.

In addition, the need to develop mechanisms for public management of budgetary security is dictated by the practice of modern public life, particularly: the disappointing economic state of our country and the difficult military-political situation in it, the global economic recession and the actual and expected consequences of the coronavirus disease pandemic-2019 and others. Given the above, a thorough, comprehensive scientific study of the problems of the mechanisms of public administration of budgetary security is extremely necessary and relevant.

The aim of this research is to develop a scientific, theoretical, and methodological foundation for managing budget security in public administration, helping to advance Ukraine's public administration system in this area.

The goal is accomplished by fulfilling the research objectives:

- review the current legal framework of Ukraine in the field of public administration of budget security;
- defining the components of the hierarchical coordination mechanism (purpose, principles, methods) to streamline management relations in the area of public administration of budget security;
- the establishment of an information and communication mechanism in public administration to enhance budget security, ensuring transparency of government actions and organizing effective informational support;
- the development of public administration functional-nodal mechanism of budget security in terms of forming the stages of the decision-making process in the studied area;
- formation of a socio-psychological mechanism as an instrument for intensifying public involvement in the public administration of budget security.

LITERATURE REVIEW

Fiscal security as a complex phenomenon of multi-vector impact is attracting more and more attention from specialists of various profiles of practical and theoretical levels. This trend is natural in view of the daily increase in threats, risks and negative factors influencing both the budget system and the process in particular, and the public finance system as a whole. In the context of the development of new public administration mechanisms against the background of the processes mentioned above, theoretical understanding and substantiation of budgetary security in the focus of public administration as a component of public administration of state security is of particular importance.

Despite the importance of considering issues of state management of budgetary security, it should be noted that research in this scientific area is extremely limited (Varnalii et al., 2020) "It has been determined that state budget is a systemically important state budget security element and a form of budget security aspect is reflected in the system of assessments that characterizes its level in dynamics and the relatively opti-

mal value of indicators and integral index. The object of budget security is the level of state budget execution, efficiency of the budget resources usage, budget process, and budget system. The subject of budget security is the activity of state authorities, financial institutions, and budget policy instruments aimed at the implementation of an adequate level of budget security.”

Buriachenko et al. (2022) examine “the theoretical principles of studying sustainability and security of public budget of the Visegrad Group countries and determine that indicators of the normal functioning of the economy and ensuring a decent social standard of living of the population are reaching the limits of relevant indicators, some of which are approved by international standards.” The authors propose to create a single system of macro-financial indicators of sustainability and security of public budget – “twelve ratios reflecting levels of debt security, deficit load on the economy, debt load on the population, budgetary independence, efficiency, population well-being, productivity, economic efficiency, as well as the effectiveness of financial support for health and education, the elasticity of income and expenditure from the change in GDP of the Visegrad countries.”

Russia’s full-scale war against Ukraine has brought changes to all spheres of social and political life. This is reflected in scientific studies by Ukrainian researchers:

- Gasanov et al. (2024) examined the impact of extraordinary challenges and threats on the national budget system, in particular, on the structure and volume of budget revenues and expenditures, the growth of the budget deficit and public debt, changes in regulation in the field of public finance, and the potential of financial capabilities of the regions;
- Zaichko et al. (2021) identified indicators of budget policy that significantly affect the public financial security and the factors of budget policy based on regression analysis do not interact closely with each other;
- Blikhar et al. (2022) defined “the essence of budget and tax security of the state, their interdependence outlines the main problems of the budget and tax security of Ukraine and considers regulatory and legal security of budget and tax sphere. A study of threats and risks to budget and tax security in the context of identified indicators is conducted.”

In the global community, the issue of budgetary systems of countries is studied at a high level (Dzigbede, Pathak, Muzata, 2023) examine whether the strength or effectiveness of national budget systems and related financial management practices moderate the impact of fiscal policy measures on economic recovery and resilience; Nessipbay et al. (2024) analyze the impact of tax administration on the balance of the state budget in the context of the country’s economic development). Still, the budgetary security is not sufficiently researched. Although Chen and Zhang (2020) note that “the tension between ensuring open government information and maintaining national security is a widespread problem around the world.” Thuy, Kim and Thanh (2022) “examine the effect of the budget balance on national financial security in the linkage of macroeconomic variables. The results indicate that budget balance has a positive effect in the short term and explains about 2.04% of Vietnam’s financial security index.” Pacheco Pardo (2018) “analyses the effects of BRI, presented as a tool of Chinese economic statecraft, on Europe’s financial security. It argues that despite the latent

challenges to said security, the potential benefits have already led many European countries to seek to tap on BRI's investment to strengthen their financing position.”

Despite the importance of considering issues of state management of budgetary security, it should be noted that research in this scientific area is extremely limited. Paying tribute to the contribution of these scientists and certain achievements in the relevant scientific field of the latter, a comprehensive understanding and applied vision of the mechanism of public administration of budgetary security has yet to be formed.

At the same time, in the context of the urgent need to form a viable methodologically organizational superstructure of public administration in the field of budgetary security, the declared object of research seems to be extremely relevant, and our research is timely.

DATA AND METHODOLOGY

The information base of the study was the data of economic statistics and financial statements on the implementation of the State budget.

The methodological basis of the study was general philosophical and general scientific methods at the theoretical and empirical levels, as well as special methods for cognizing phenomena and processes within the framework of public administration of budgetary security. The development of methodological provisions for the state management of budgetary security was carried out using the methods of theoretical generalization and systematization, modeling, a synergistic approach, modeling, comparative analysis and concretization, and formalization.

Methods of theoretical generalization, analysis, synthesis, abstract-logical method, modeling, and formalization contributed to the formation of the institutional model of public administration of budgetary security. In the process of development of practical elemental mechanisms of state management of budgetary security, methods of analysis and synthesis, induction and deduction, formalization, modeling, concretization, abstract-logical method, logic and classification were applied.

RESULTS AND DISCUSSIONS

Based on the processing of these approaches, taking into account the stated positions of the author regarding the theoretical foundations and methodological provisions of the state management of budgetary security, it is proposed to single out the following block mechanisms of state management of budgetary security with their subsequent processing:

- Block “Frame-supporting mechanisms”:
 - hierarchically coordinating – a mechanism of subordinate correlation of subjects of state management of budgetary security and their interdepartmental coordination and interaction;
 - information and communication – a mechanism for receiving, processing and transmitting information within the public administration of budgetary security;

- Block “Functional-nodal mechanisms”:
 - directive-functional – a mechanism for the preparation, adoption and implementation of general management decisions to ensure budgetary security, both in the context of achieving goals directly and organizing the achievement of the latter;
 - political and strategic mechanism for the formation of policy and strategy of public administration of budgetary security;
 - financial and budgetary – a mechanism for operational/current financial management actions to ensure budgetary security;
- Block “Social security mechanisms”:
 - motivational-stimulating – a mechanism for motivating and stimulating employees whose functional duties include ensuring budgetary security;
 - moral and ethical – a mechanism for ensuring compliance with moral and ethical standards in the process of public administration of budgetary security;
 - socio-psychological – a mechanism of persuasion about the need and their own involvement of citizens in the state management of budgetary security, as well as the importance of the latter.

Consequently, each of the above mechanisms has its own goal within the framework of the general goal of public administration of budgetary security – to achieve the necessary and sufficient level of budgetary security for the effective and productive functioning of the institution of the state.

It is proposed to choose a canvas of components: goals, principles, functions, methods, technologies, tools, levers, incentives, provision, and practical measures. At the same time, for each individual of the specific mechanisms of public management of budgetary security, these components are identified as partial to the general, in particular: subgoals to the goal, certain principles, functions, methods, technologies, tools, levers, incentives, provision, and measures in practice.

The study of the current regulatory legal field made it possible to form such a modern functional model of the regulatory support of public administration of budgetary security (Fig. 1).

Figure 1. Regulatory Model for Public Administration of Fiscal Security

Regulations on planning/forecasting budgetary security	Regulations on the organization of achievement budget security
<p>On the decision of the National Security and Defense Council of Ukraine dated September 14, 2020 “On the National Security Strategy of Ukraine”: Decree of the President of Ukraine No. 392/2020 dated September 14, 2020</p> <p>On the approval of the Concept of ensuring national security in the financial sphere: Decree of the Cabinet of Ministers of Ukraine dated August 15, 2012 No. 569</p> <p>On the approval of the Strategy for Reforming the State Finance Management System for 2017–2020: Decree of the Cabinet of Ministers of Ukraine dated February 8, 2017 No. 142</p>	<p>Constitution of Ukraine: Law of Ukraine dated 28.06.1996 No. 254k/96-VR</p> <p>On the foundations of the national security of Ukraine: Law of Ukraine dated June 19, 2003 No. 964-IV</p> <p>Budget Code of Ukraine dated 21.06. 2001 No. 2542-III.</p> <p>On approval of the Guidelines for calculating the level of economic security of Ukraine: Order of the Ministry of Economic Development and Trade of Ukraine dated 29.10.2013 No. 1277</p> <p>Laws “On the State Budget of Ukraine for the corresponding year.» decisions on local budgets for the corresponding year, etc.</p>

Regulations on Motivation to Achieve Budgetary Security	Regulations for monitoring the achievement of budgetary security
<p>On public service: Law of Ukraine dated 10.12.2015 No. 889-VIII</p> <p>Numerical internal regulations of the relevant subjects of state management of budgetary security on material and other types of incentives for employees</p>	<p>Constitution of Ukraine: Law of Ukraine dated 28.06.1996 No. 254k/96-VR</p> <p>On approval of the Guidelines for calculating the level of economic security of Ukraine: Order of the Ministry of Economic Development and Trade of Ukraine dated 29.10.2013 No. 1277</p> <p>Budget Code of Ukraine dated 21.06. 2001 No. 2542-III.</p> <p>On the basic principles of the implementation of state financial control in Ukraine: Law of Ukraine dated January 26, 1993 No. 2939-XII</p> <p>On approval of the procedure for assessing the performance of civil servants: Decree of the Cabinet of Ministers of Ukraine dated 23.08.17 No. 640</p> <p>On public service: Law of Ukraine dated 10.12.2015 No. 889-VIII</p> <p>Criminal Code of Ukraine: Law of Ukraine dated April 5, 2001 No. 2341-III</p>

Source: Own work.

Regarding the subjects of state management of budgetary security, the appeal to the above regulations made it possible to form a subject circle of state management of budgetary security.

Within the framework of the latter, it is proposed to distinguish two groups, in particular: subjects of direct management action (President of Ukraine – hereinafter PU; National Security and Defense Council of Ukraine – hereinafter NSDCU; Verkhovna Rada Ukraine – hereinafter VRU; Protection of Ukraine – hereinafter SBU, Ministry finance of Ukraine – hereinafter MFP; Civil Service – hereinafter NAUSS) and objects of injection management of activities (State Treasury Service of Ukraine; State Audit Office of Ukraine; State Fiscal Service of Ukraine; State Customs Service of Ukraine; In this case, the first group is directly involved in public administration of budgetary security – the performance of its main functions, and the second – indirectly ensures the implementation of public administration of budgetary security through the totality of its functional powers, realizing, in a certain way, additional functions of public administration of budgetary security (Fig. 2).

Its construction will contribute to the formation of clear mechanisms for the state management of budgetary security, and consequently increase the efficiency and effectiveness of the state management of budgetary security itself.

In order to build a hierarchical-coordination mechanism within the state management of budgetary security, it is proposed to form the latter in the context of the subjects of state management of budgetary security through establishing appropriate managerial relations between them. In the context of the object of study, to solve this problem, based on the identification and addition of managerial relations PU, VRU, NSDCU, CMU, SBU, BESU, ACU and other subjects of state management of budgetary security, a hierarchical-coordinating mechanism of state management of budgetary security in the context of three types of managerial connections: subordination, coordination, reordination (Fig. 3).

Figure 2. Dynamic-functional institutional model of public budget security administration

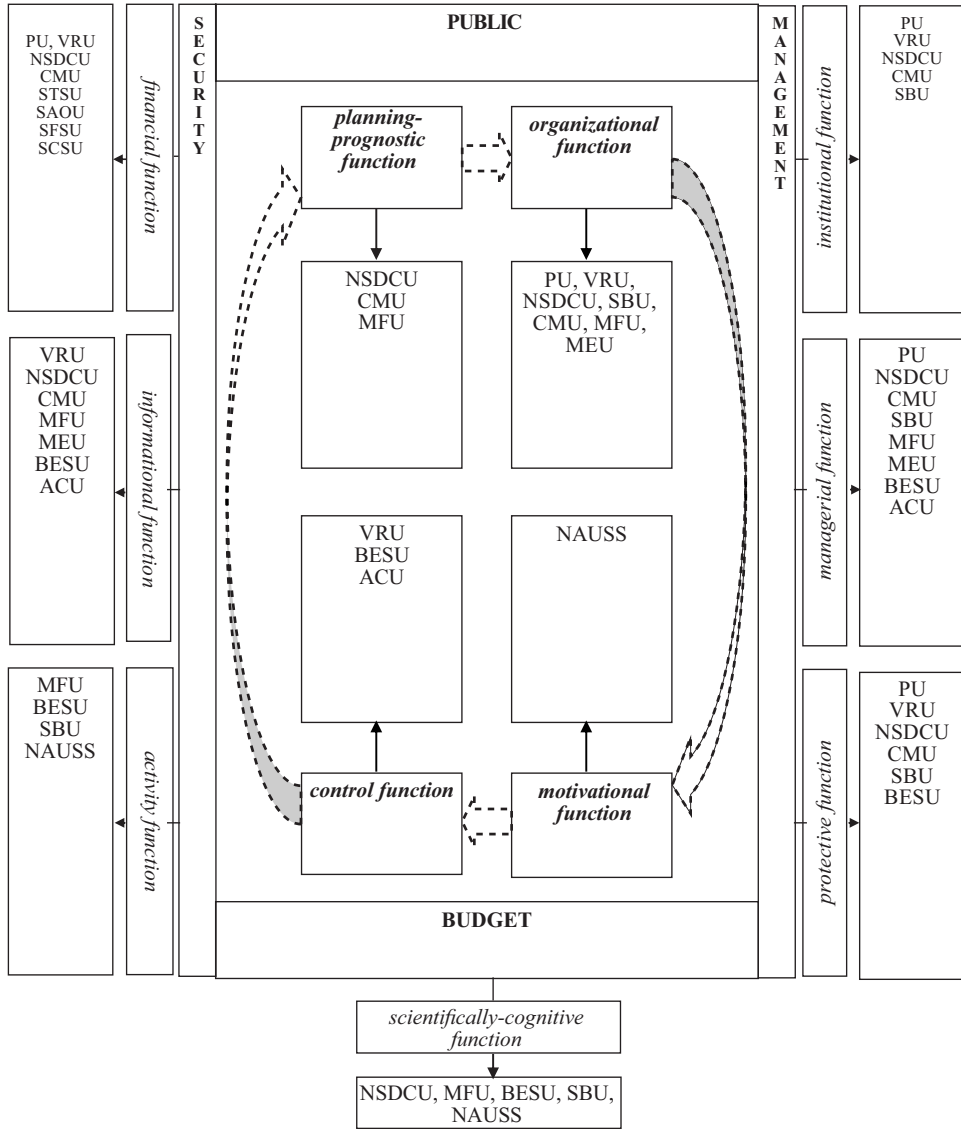

Source: Own work.

Regarding the components of the canvas of the hierarchically coordinating mechanism, some of them are seen as follows:

- purpose (formation of managerial links between the subjects of public administration of budgetary security to ensure its implementation);
- principles: hierarchy, rationality, interconnection, simultaneity, consistency, balance, balance, unity, redundancy, reliability, clarity, efficiency, response, democracy, publicity; function – organisational;

- methods – administrative; methods, activities: sighting and other methods of control, vertical distribution of tasks, creation of commissions and committees, horizontal meetings, dissemination of information, negotiations, observation, development of rules, procedures, schedules, norms, plans, regulations, etc., synchronisation of actions in time; technologies – information-analytical and organisational; regulatory support (Svirko, 2021).

Figure 3. Hierarchical-coordination mechanism of state budget security management

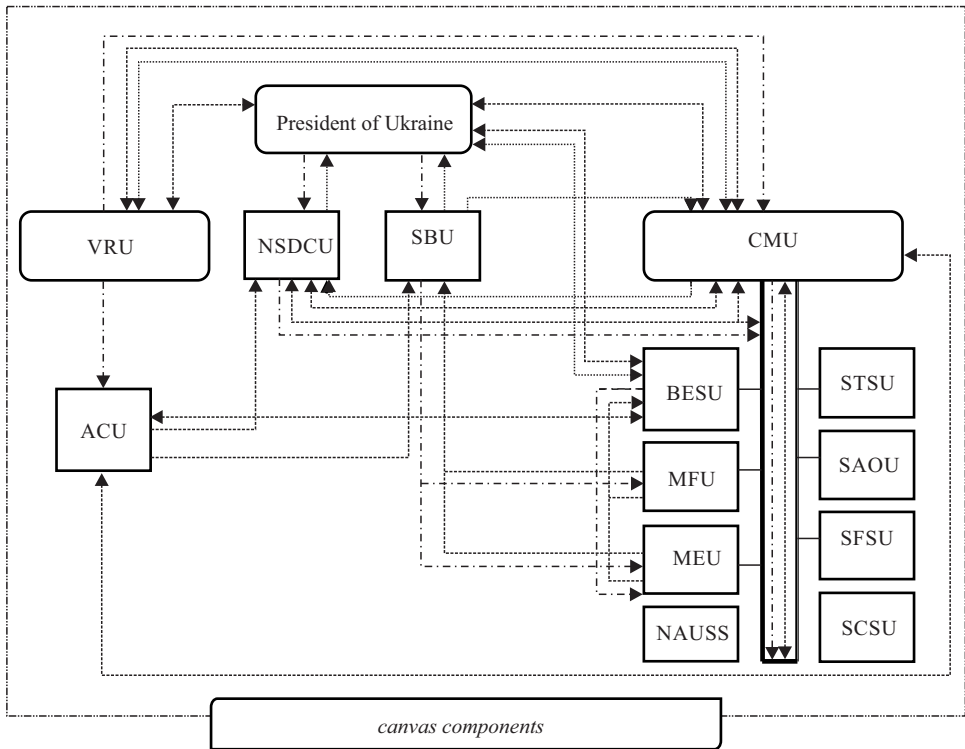

(designation subordination, - - - - - coordination, reordination, — vertical institutions of executive power (hereinafter – IEP))

Source: Own work.

The introduction of this mechanism will contribute to the development and subsequent streamlining of managerial relations within the framework of public administration of budgetary security. The next to be processed in the first block of mechanisms is the information and communication mechanism of state management of budgetary security. Its construction is extremely necessary for a number of good reasons, among which the need to implement the principle of publicity of state power and the organisation of information support for the process of state management of budgetary security is key. For the development of the information and communication mechanism, it is proposed to classify the information flows of managerial information according to the

following criteria and their corresponding groupings: types of information (statistical, administrative, legal, mass, activity, personal), availability (limited, open access), purpose (processing, familiarisation).

Taking into account the identified positions of the task and within the framework of solving the latter, the above proposals, the information and communication mechanism of the state management of budgetary security takes on the following form (Fig. 4).

Regarding the components of the canvas of the hierarchical-coordination mechanism, some of them are seen as follows (Svirko, 2021):

- goal (formation of information links for receiving, processing and transmitting information within the state management of budgetary security);
- principles: democracy, alternativeness, consensus, manufacturability, transparency, neutrality, accessibility, stimulation, openness, cooperation, mutual respect, information parameters, free of charge;
- function – organisational, managerial, informational;
- methods – administrative; ways,
- events: exchange of documents, meetings, meetings, negotiations, meetings, sessions, plenums, conferences, hearings, individual reception, informing, consulting, dialogue, partnership, etc.;
- technologies – information-analytical and organisational; regulatory support.

In order to develop the functional-nodal mechanisms of state management of budgetary security, it is proposed to understand the adoption of state-administrative decisions on budgetary security as a science-based process of forming a professional, effective response by the subjects of budgetary security management to the actual or forecast situation of budgetary security in the country in the context of an alternative choice with a consistent its legal opinion (Svirko, 2021).

It is recommended to single out current and long-term state-administrative decisions in the field of budgetary security.

The stages of the process of making managerial decisions in the field of public administration of budgetary security as a whole have been formed (Svirko, 2021):

- preparatory stage (preparation for making a managerial decision in the context of stages): identifying, developing, and prioritising the problems of public administration of budgetary security, including from the point of view of a situational approach; establishing restrictions and criteria for making managerial decisions in the field of budgetary security;
- formative stage (the stage of development and adoption of a managerial decision in the context of stages): formation of a set of alternative managerial decisions in the field of budgetary security, their evaluation and selection of the optimal one; determination of resource provision, finalisation and adoption of a managerial decision in the field of budgetary security;
- implementation stage (the stage of implementation of the management decision itself in the context of stages): practical implementation of the management decision in the field of budgetary security; control over the implementation of management decisions in the field of budgetary security and adjustment of the latter; evaluation of the results of the implementation of managerial decisions in the field of budgetary security and the adoption of corporate decisions upon its implementation.

Figure 4. Informational and communication mechanism of state budget security management

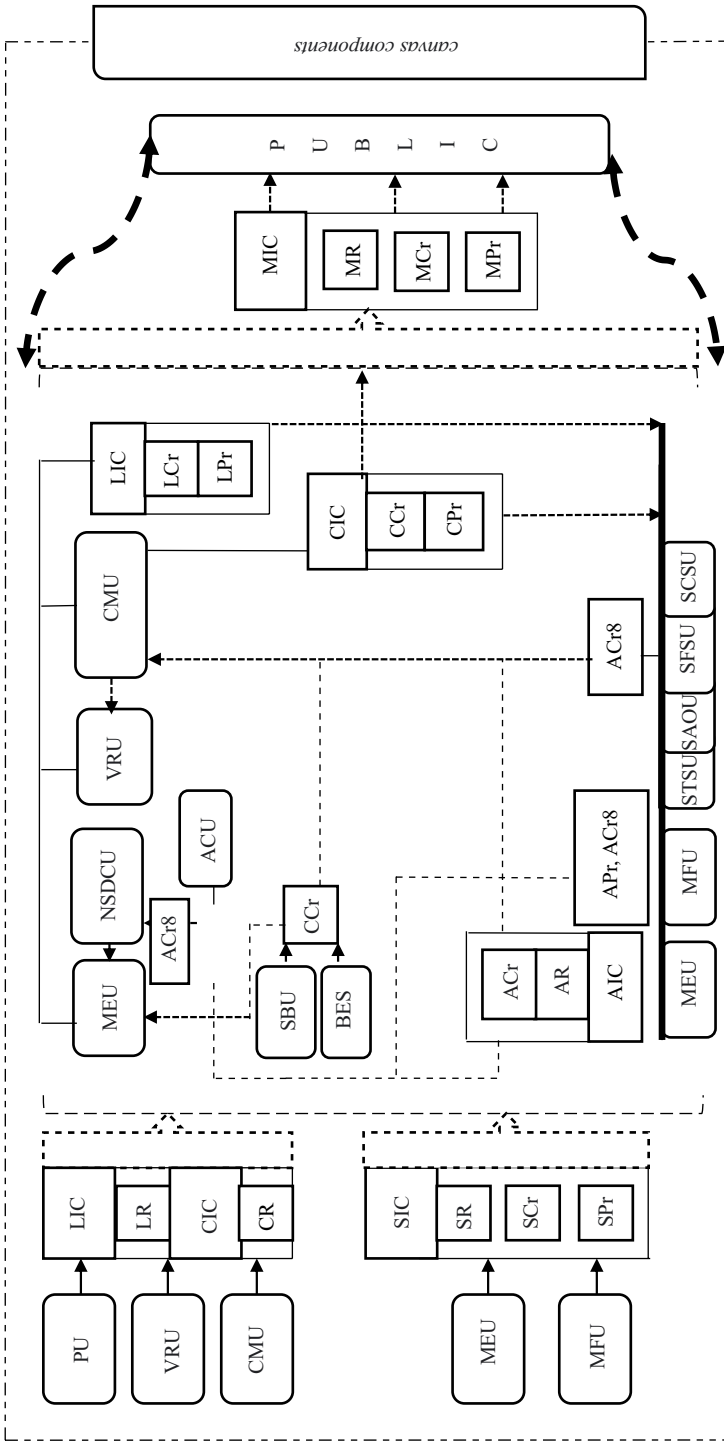

* where: SIC – statistical information cluster; AIC – administrative information cluster; CIC – activity information cluster; LIC – legal information cluster
 MIC – mass information cluster; SR – a retrospective segment of the statistical information cluster on the basis of time; SCr – the current segment of the statistical information cluster on the basis of time; SPr – a promising segment of the statistical information cluster on the basis of time;
 AR – a retrospective segment of the administrative information cluster on the basis of time; ACr – the current segment of the administrative information cluster on the basis of time; APr – a promising segment of the administrative information cluster on the basis of time; CR – a retrospective segment of the activity information cluster on the basis of time; CCr – the current segment of the activity information cluster on the basis of time; CPr – a promising segment of the activity information cluster on the basis of time;
 LR – a retrospective segment of the legal information cluster on the basis of time; LCr – the current segment of the legal information cluster on the basis of time; LPr – a promising segment of the legal information cluster on the basis of time; MR – a retrospective segment of the mass information cluster on the basis of time; MCr – the current segment of the mass information cluster on the basis of time; MPr – a promising segment of the mass information cluster on the basis of time.

Source: Own work.

Considering the above provisions and proposals, the complex functional-nodal mechanism in the context of directive-functional, political-strategic, and financial-budgetary mechanisms is as follows (Fig. 5).

It provides for the identification of a situational and conservative field of stages and stages of making government management decisions on budgetary security, as well as the subjective participation of each stage of the latter.

Figure 5. Complex functional-nodal mechanism of state budget security management

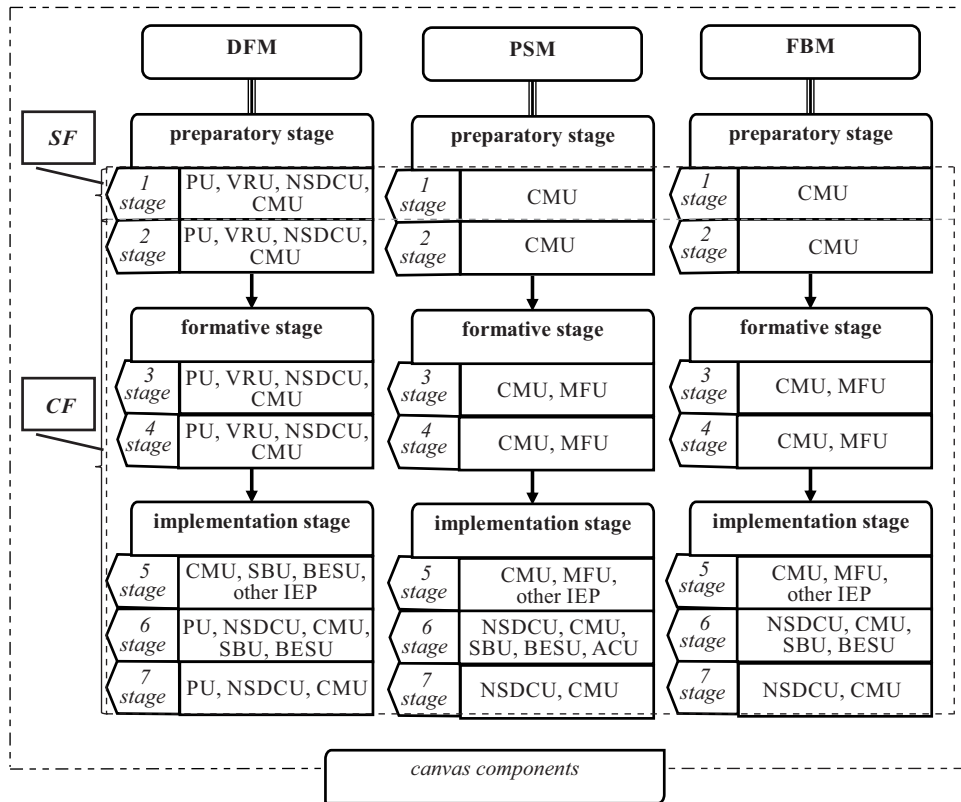

*SF – situational field, CF – conservative field, DFM – directive-functional mechanism, PSM – political-strategic mechanism, FBM – financial-budgetary mechanism

Source: Own work.

The components of the canvas of this mechanism are offered in the following interpretation:

- purpose (formation of the procedure for making state management decisions in the field of budgetary security based on the previously established concept of provisions and approaches to ensure the implementation of state management of budgetary security);
- principles: resource saving, feedback, relevance, strategic thinking, control, efficiency, economy, timeliness, reliability, scientific validity, unity, complexity, flex-

ibility, legitimacy, quantitative and qualitative expression, optimality, focus, specificity in time, efficiency and timeliness, correspondence, selectivity, necessary and sufficient conditions, variety of ways of professionalism, individuality, subjective probability, compromise, timeliness, adequacy, resource provision, compensation for limited rationality, degrees of freedom;

- functions – planning/forecasting, organisational, control, institutional, managerial, protective, financial, informational, activity;
- methods – administrative, methods of direct administration (including strategic audit), economic (including budgetary regulation), scientific and analytical;
- methods, measures: legal and organisational and administrative documents, meetings, protocols, reports, information-analytical, explanatory and memos, contracts, agreements, regulations, instructions, acceptance certificates, plans, schedules, reports; target, functional, compositional, multiple, behavioural approaches in assessing the effectiveness and efficiency of activities;
- technologies – information-analytical and organisational; regulatory support.

Formation of a socio-psychological mechanism as a tool for activating the involvement of the public in the state management of budgetary security (the mechanism of persuasion about the need and the own involvement of citizens in the state management of budgetary security, as well as the importance of the latter), in the absence of identification of the concept of “budgetary security” in modern domestic public society and, consequently, the latter’s understanding of the importance of this area of national/state security seems to be not only relevant but also extremely necessary.

It should be noted that this state of affairs is no exception: according to a survey by the Razumkov Center, 57% of respondents do not support the activities of the main governing bodies, 75% do not trust political parties, 52.5% do not trust local authorities, and 79% do not know how to deal with their deputy constituency (Razumkov Center). This state of affairs is unacceptable and requires immediate intervention and correction.

It should be noted that the National Strategy for the Development of Civil Society in Ukraine for 2016–2020, approved by the Decree of the President of Ukraine dated February 26, 2016, No 68/2016, and the Law of Ukraine “On Education” dated September 5, 2017, No. 2145-VIII, should be the basis of such a mechanism. In the context of the above documents, within the framework of the socio-psychological mechanism of state management of budgetary security, the following target instrumental segments are proposed: training, retraining, and self-training.

On the basis of the above, the socio-psychological mechanism of public administration of budgetary security takes on a form where its elements are: the governing bodies of the process of preparing the public community in the field of public administration of budgetary security; participants in the process of preparing a public society in the field of public administration of budgetary security by type of education; canvas components (Fig. 6).

At the same time, the canvas of components includes:

- purpose (formation of maximum public awareness on the issues of public administration of budgetary security to create a socio-psychological basis for its active participation in the latter);

Figure 6. Socio-psychological mechanism of public administration of budget security

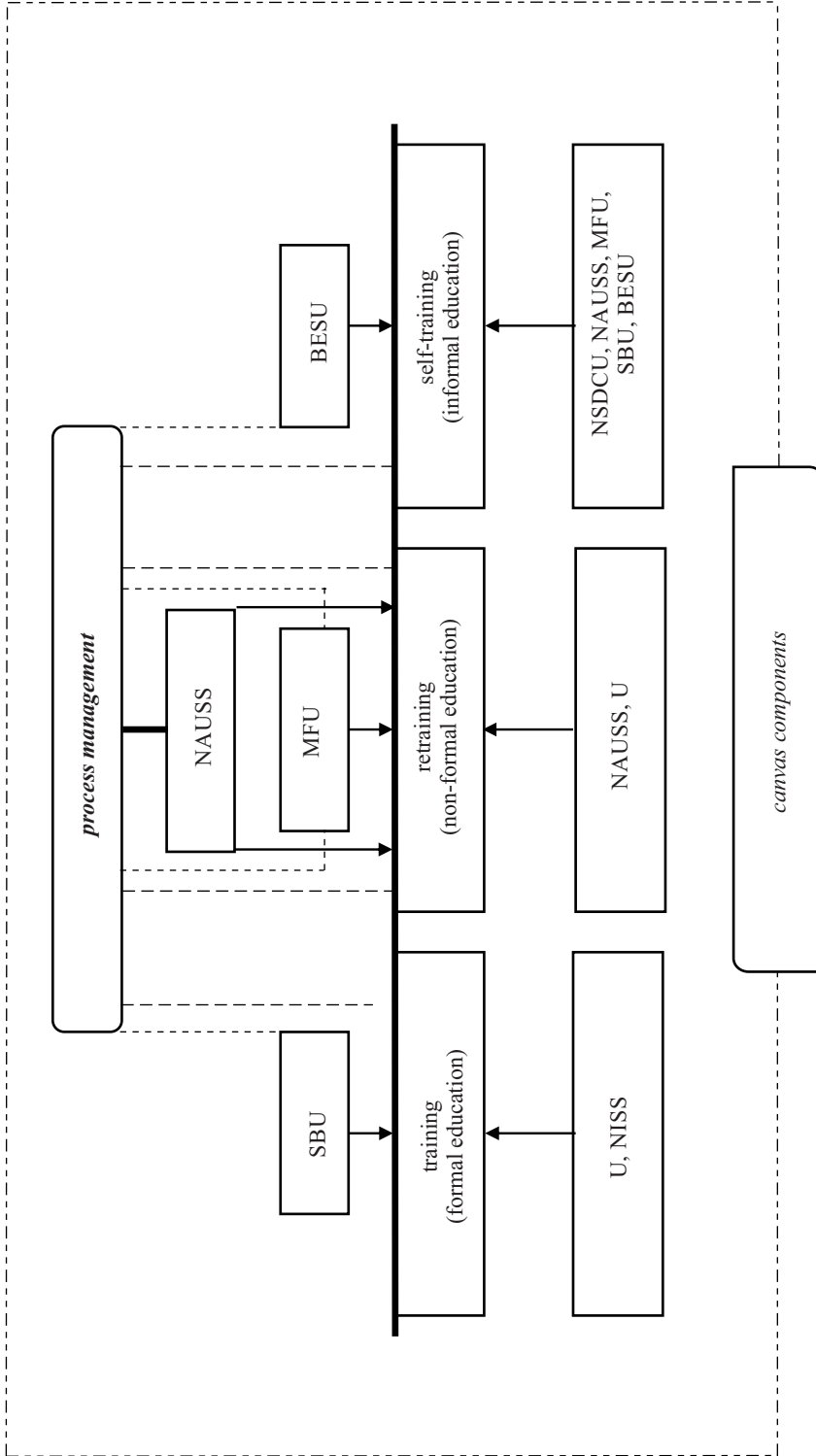

*NISS – National Institute for Strategic Studies, U – universities
 Source: Own work.

- principles: the rule of law, constructiveness, freedom, democracy, morality, publicity, transparency, human-centeredness, virtue, humanism, scientific justification, complexity, integrity, equality, partnership, accessibility, impartiality, continuity, openness, etc.;
- function (motivational, informational, scientific-cognitive, activity);
- methods (administrative, methods of direct administration, scientific and analytical);
- methods, activities: training, consulting, scientific research, informing, agitation, clarification etc.;
- technologies (information-analytical and organisational); regulatory support (normative acts listed above).

The introduction of the developed socio-psychological mechanism of public administration will contribute to creating a consciously logically cumulative age information basis for active public participation in the public administration of budgetary security.

CONCLUSIONS AND RECOMMENDATIONS

As a result of the study, the goal was achieved, which was to develop a scientifically theoretical and methodological position and public management of budget security. In particular, the following ideas have been formed: the functional model of the regulatory support of public administration of budgetary security in terms of allocation of regulations on the planning/forecasting, organisation, motivation, and monitoring of achievement of budget security.

In order to achieve the necessary and sufficient level of budgetary security for the effective and productive functioning of the institution of the state, enhance a complex functional-nodal, hierarchical coordination, information, and communication, a socio-psychological mechanism of public administration of budgetary security.

The components of the hierarchical-coordination mechanism have been defined, which allowed to streamline the management contacts between the subjects of the public administration of budget security.

This contributes to the implementation of the principle of publicity of the State power and ensures the efficiency of information provision. Creating a functional-nodal mechanism for managing budget security in public administration requires defining specific stages in the decision-making process within this field. In order to intensify public involvement in the public administration of budget security, a socio-psychological framework has been developed, the elements of which are as follows: the governing bodies of the process of preparing the public community in the field of public administration of budgetary security; participants in the process of preparing a public society in the field of public administration of budgetary security by type of education.

The introduction of a complex functional-nodal, as well as hierarchical-coordination, information-communication and socio-psychological mechanisms of state management of budgetary security will allow for the preparation, formation, legitimization and implementation of state-administrative decisions in the field of budgetary security

at a fundamentally new scientifically-based level with a maximum effectiveness and efficiency, will contribute to the development and streamlining of managerial relations, will create science-based, optimal and verified information links of direct and reverse action, will contribute to the creation of a science-based information basis for active public participation in the framework of public administration of budgetary security, will become an impetus for the development of a scientific and educational basis for activities in the field of public administration of budgetary security, which will provide an opportunity to train highly qualified frames of the corresponding profile.

The implementation of the model of the integral mechanism of public administration of budgetary security as a formalized representation of an inseparably united set of various mechanisms of public administration of the latter in a common outline of components will ensure the formation of an effective and efficient system of current and strategic public administration of budgetary security, therefore, will help strengthen the financial position of the state. The systemic nature of the presented scientific results will make it possible to introduce the existing mechanisms of public administration of budgetary security in the shortest possible time.

At the same time, the development of the assessment of budgetary security, forecasting and planning of the latter, as well as, in the context of recent processes, a multi-vector identification of risks on the way to achieving budgetary security and factors influencing them, need additional processing. For their improvement, the integrated implementation of the research results will increase the effectiveness of the public finance management system, and therefore ensure the stabilization and further development of the public finances of Ukraine.

REFERENCES

- Blikhar M., Melnychenko B., Pylypyshyn P., Ryzhkova A., Ruvin S. (2022), *Economic and Legal Justification of the Methodological Approach to the Assessment of the State of budget and tax Security of Ukraine*, "Financial and credit activity problems of theory and practice", 2(43), DOI: <https://doi.org/10.55643/fcapter.2.43.2022.3756>.
- Bogma O. S. (2017), *Harakterystyka osnovnyh metodiv upravlinnja bjudzhetnoju bezpekoju Ukrai'ny* [Characteristics of the main methods of budget security management in Ukraine], "Problemy i perspektyvy rozvytku pidpryjemnytva", 1: 41–45.
- Buriachenko A., Zakhohay K., Liezina A., Lysak V. (2022), *Sustainability and security of public budget of the Visegrad Group countries*, "Acta Innovations", Vol. 2022, Issue 42, DOI: <https://doi.org/10.32933/ActaInnovations.42.6>.
- Chen L., Zhang J. (2020), *The Blurred Boundaries Between Budget Transparency and State Secrecy: a Survey of Three Departments Across 36 Chinese Municipalities*, "East Asia", Vol. 37.
- Dzigbede K. D., Pathak R., Muzata S. (2023), *Budget systems and post-pandemic economic resilience in developing countries*. *Journal of Public Budgeting*, "Accounting & Financial Management", 35(3), DOI: <https://doi.org/10.1108/JPBAFM-03-2021-0036>.
- Gasanov S., Ivashchenko O., Bartosh S., Klymenko K., Ukhnał N. (2024), *Transformation of the Budget System of Ukraine in the Face of Extraordinary Challenges and Threats*, "Financial & Credit Activity: Problems of Theory & Practice", Vol. 1(54), DOI: <https://doi.org/10.55643/fcapter.1.54.2024.4261>.

- Grytsyshen D., Svirko S. V., Suprunova I. V. (2019), *Bjudzhetna bezpeka jak ob'jekt analitychnykh doslidzhen' v umovah reformuvannja systemy upravlinnja miscevyjmy bjudzhetamy* [Budget security as an object of analytical research in the context of reforming the local budget management system], "Investycii: praktyka ta dosvid", Vol. 24.
- Grytsyshen D., Dragan I., Sergiienko L., Ivanyuta V., Dolinchenko O. (2022), *Information and Communication Technologies in the Public Administration System in the Context of Socio-Economic Development*, "IJCSNS International Journal of Computer Science and Network Security", Vol. 22, No. 1.
- Grytsyshen D., Sergiienko L., Ksendzuk V. (2019), *The system of public-private partnership in the sphere of state policy implementation of circular economy*, "Journal of Corporate Responsibility and Leadership", Vol. 3(6).
- Jevdokymov V. V., Svirko S. V., Suprunova I. V. (2020), *Identyfikacija skladovykh derzhavnoi' bezpeky jak ob'jektiv derzhavnogo upravlinnja* [Identification of components of state security as objects of public administration], "Derzhavne upravlinnja: udoskonalennja ta rozvytok", Vol. 12.
- Jevdokymov V. V., Svirko S. V. (2020), *Bjudzhetnyj kodeks Ukra'ny jak osnovnyj instrument normatyvno-pravovogo suprovodu derzhavnogo upravlinnja bjudzhetnoju bezpekoju* [Budget security: place and role in the modern mechanism of public administration], "Naukovi perspektyvy", Vol. 3.
- Jevdokymov V. V., Svirko S. V., Tarasova T. O. (2021), *Obg'runtuvannja ponjatijnoi' osnovy ta struktury derzhavnoi' bezpeky jak ob'jektu derzhavnogo upravlinnja* [Substantiation of the conceptual basis and structure of state security as an object of public administration], "Tehnologichnyj audyt ta rezervy vyrobnyctva", Vol. 4/4(60).
- Kovbasjuk Ju. V. (2012), *Derzhavne upravlinnja: u 2 t.* [Governance], NADU, Dnipropetrovsk.
- National Security Articles – Inquiries Journal*, <http://www.inquiriesjournal.com/keyword/national-security> (19.03.2022).
- National Security: News, Analysis and Opinion from POLITICO*, <https://www.politico.com/news/national-security> (19.03.2022).
- Nessipbay O., Tagabay B., Serikova M., Zhagyparova A., Basshieva Z., Sembiyeva L. (2024), *Analysis of the Impact of tax Administration on the Balance of the State Budget in the Context of the Country's Economic Development*, "Montenegrin Journal of Economics", Vol. 19(3), DOI: <https://doi.org/10.14254/1800-5845/2024.20-3.17>.
- Pacheco Pardo R. (2018). *Europe's financial security and Chinese economic statecraft: the case of the Belt and Road Initiative*, "Asia Europe Journal", Vol. 16, DOI: <https://doi.org/10.1007/s10308-018-0511-z>.
- Pro nacionalnu bezpeku Ukrainy [Law of Ukraine «On National Security of Ukraine»]: Zakon Ukrainy №2469-VIII vid 21.06.18, <https://zakon.rada.gov.ua/laws/show/2469-19> (25.03.2022).
- Pro rishennja Rady nacionalnoi bezpeky i oborony Ukrainy «Pro Strategiju nacionalnoi bezpeky Ukrainy»* [Decree of the President of Ukraine «On the National Security Strategy of Ukraine»] (September 14, 2020), <https://zakon.rada.gov.ua/laws/show/392/2020#Text> (23.03.2022).
- Pro zatverdzhennja Metodichnykh rekomendacij shhodo rozrahunku rivnja ekonomichnoi bezpeky Ukrainy* [Order of the Ministry of Economic Development and Trade of Ukraine «On approval of Methodical recommendations for calculating the level of economic security of Ukraine»], Nakaz Ministerstva ekonomichnogo rozvytku i torgovli Ukra'ny vid 29.10.2013, № 1277, <https://zakon.rada.gov.ua/rada/show/v1277731-13> (25.03.2022).
- Razumkov Center*: official website, <https://razumkov.org.ua/> (25.03.2022).

- Svirko S. V. (2021), *Mechanizmy derzhavnogo upravlinnja bjudzhetnoju bezpekoju* [Mechanisms of state budget security management], Vyd. O.O. Jevenok Zhytomyr, <http://eztuir.ztu.edu.ua/bitstream/handle/123456789/7905/Cbipko.pdf?sequence=1&isAllowed=y> (23.03.2022)].
- Svirko S. V., Tarasova T. O. (2021), *Bjudzhetna bezpeka: misce ta rol v suchasnomu mehanizmi derzhavnogo upravlinnja* [eng], "Visnyk HNAU im. V. V Dokuchajeva", Vol. 1.
- Thuy T. H., Kim O. T. T., Thanh T. P. (2022), *The impact of Government budget on national financial security: a case study in Vietnam*, "Macroeconomics and Finance in Emerging Market Economies", Vol. 17, Issue 2, DOI: <https://doi.org/10.1080/17520843.2021.2010169>.
- Varnalii Z., Onyshchenko S., Filonych O., Maslii O. (2020), *State policy for ensuring budgetary security of Ukraine in terms of financial globalization*, "International Journal of Management", Vol. 11, Issue 12, DOI: <https://doi.org/10.34218/IJM.11.12.2020.215>.
- Zaichko I., Vysotska M., Miakyshevska O., Kosmidailo I., Osadchuk N. (2021), *Modelling of Public Financial Security and Budget Policy Effects*, "International Journal of Computer Science & Network Security", Vol. 21(9), DOI: <https://doi.org/10.22937/IJCSNS.2021.21.9.32>.

ABSTRACT

The article solves the problem of developing the mechanisms of public administration of budgetary security in Ukraine. The aim of this research is to develop a scientific, theoretical, and methodological foundation for managing budget security in public administration, helping to advance Ukraine's public administration system in this area. The allocation of mechanisms of state management of budgetary security in Ukraine for specific blocks is substantiated: "Frame-supporting mechanisms;" "Functional-nodal mechanisms;" "Social support mechanisms." A model of the integral mechanism of public administration of budgetary security has been formed as a formalised representation of an inseparably united set of various mechanisms of public administration of the latter in a common outline of components. A model of normative provision of state management of budgetary security has been worked out, and the latter has been institutionalised in the context of subjects of direct and indirect guiding action. A hierarchical-coordination mechanism of state management of budgetary security has been built in the context of three types of managerial relations: subordination, coordination, re-ordination. A complex functional-nodal mechanism of public administration of budgetary security with an appropriate outline of components has been formed. A socio-psychological mechanism of state management of budgetary security has been developed in the context of such target instrumental segments: training, retraining, and self-training.

Keywords: budgetary security, public administration mechanisms, public administration of budgetary security

BEZPIECZEŃSTWO BUDŻETU PAŃSTWA: MECHANIZMY ZARZĄDZANIA PUBLICZNEGO W UKRAINIE

STRESZCZENIE

Artykuł porusza problem rozwoju mechanizmów administracji publicznej w zakresie bezpieczeństwa budżetowego na Ukrainie. Celem badania jest opracowanie naukowych, teoretycznych i metodologicznych podstaw zarządzania bezpieczeństwem budżetowym w admini-

stracji publicznej, co ma na celu usprawnienie systemu administracji publicznej Ukrainy w tym obszarze. Uzasadniono podział mechanizmów zarządzania państwowego bezpieczeństwem budżetowym na Ukrainie na konkretne bloki: „mechanizmy ramowo-wspierające”, „mechanizmy funkcjonalno-węzłowe”, „mechanizmy wsparcia społecznego.” Opracowano model integralnego mechanizmu administracji publicznej w zakresie bezpieczeństwa budżetowego jako sformalizowaną reprezentację nierozłącznie zjednoczonego zestawu różnych mechanizmów administracji publicznej we wspólnej strukturze komponentów. Stworzono model normatywnego zapewnienia zarządzania państwowego bezpieczeństwem budżetowym, który został zinstytucjonalizowany w kontekście podmiotów działania bezpośredniego i pośredniego. Zbudowano hierarchiczno-koordynacyjny mechanizm zarządzania państwowego bezpieczeństwem budżetowym w kontekście trzech typów relacji zarządczych: podporządkowania, koordynacji i re-koordynacji. Opracowano kompleksowy mechanizm funkcjonalno-węzłowy administracji publicznej w zakresie bezpieczeństwa budżetowego z odpowiednim zarysem komponentów. Rozwinięto mechanizm społeczno-psychologiczny zarządzania państwowego bezpieczeństwem budżetowym w kontekście takich segmentów instrumentalnych, jak: szkolenie, przekwalifikowanie, samokształcenie.

Słowa kluczowe: bezpieczeństwo budżetu państwa, mechanizmy zarządzania publicznego, zarządzanie publiczne budżetem państwa